



Eurotec®

The specialist for fastening technology

OUR SCREW FOUNDATIONS

PRODUCT RANGE & BASICS

COMPONENTS & VARIANTS

SPECIAL ADAPTERS &
ATTACHMENTS

ACCESSORIES



CONTENTS

BASICS OF SCREW FOUNDATIONS	04-07
AN OVERVIEW OF OUR PRODUCT RANGE	08-09
SCREW FOUNDATIONS 60 SERIES	10-11
SCREW FOUNDATIONS 76 SERIES	12-13
SCREW FOUNDATIONS 89 SERIES	14-15
SCREW FOUNDATIONS 114 SERIES	16-17
ACCESSORIES	18-24

SCREW FOUNDATIONS – AN OVERVIEW OF THE MOST IMPORTANT QUESTIONS

DEFINITION AND FUNCTION

Screw foundations are rotationally symmetrical steel piles that are driven vertically into the ground using hydraulic or electric driving equipment. Within minutes, they are firmly anchored and immediately serve as a reliable foundation – without any excavation or concrete work. A fast, clean, and resource-efficient method for launching construction projects.

HOW MUCH WEIGHT CAN THESE FOUNDATIONS SUPPORT?

The system offers high load-bearing capacity: a variety of diameters, lengths, and designs ensure that even challenging substrates are reliably supported.

WHAT KINDS OF PROJECTS ARE THEY SUITABLE FOR?

This foundation solution is used wherever flexible construction is required: for tiny houses, modular buildings, mobile units, shelters, carports, or other structures that need a stable yet simple foundation. Perfect for both temporary and permanent installations.

WHY NOT JUST USE CONCRETE?

Concrete foundations require excavation, extensive preparation, and long curing times. Screw foundations eliminate all of that: they can be installed quickly, are ready for use immediately, and can even be relocated or removed later without leaving any residue. Less effort, more flexibility – and often significantly lower overall costs.



VERSATILE,
RUGGED,
DURABLE



CARPORT



TINY HOUSE

ASSEMBLY PROCESS

Installation is performed using a controlled torque setting, which can be monitored via the installation tool. Depending on the dimensions and ground conditions, small to medium-sized foundation grids can be installed within a single workday. The load-bearing capacity is available immediately after installation, as no setting or curing times are required.

SUSTAINABILITY AND DEMOUNTABILITY

Since there is no soil sealing and no concrete-based materials are used, screw piles meet high environmental standards. They can be completely dismantled and returned to the material cycle without permanently altering the subsoil.

APPLICATIONS

Whether it's a tiny house, a patio, or a carport—this product is the reliable solution for a wide range of outdoor applications. It also impresses with its flexibility and stability when used for fences, play structures, balcony decking, beach houses, flagpoles, and ground-mounted solar systems. Thanks to its versatility, it's ideal for both residential and commercial projects. A solution that delivers lasting performance outdoors.

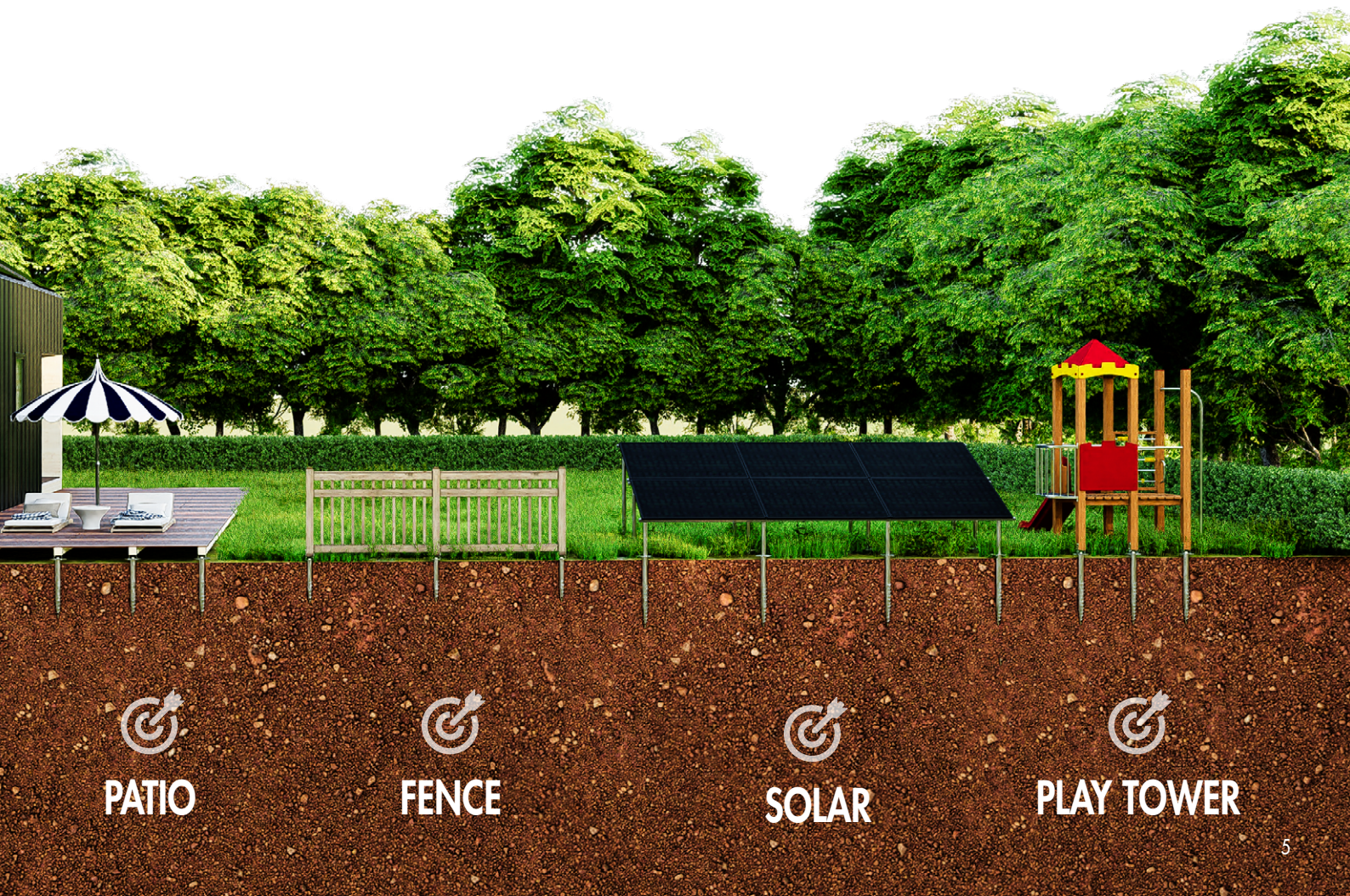

TECHNICAL INFORMATION

MATERIAL

Our screw foundations are made of S355 structural steel and are hot-dip galvanized in accordance with DIN EN ISO 1461 to provide lasting protection against corrosion. The zinc coating has a thickness of $\geq 70 \mu\text{m}$ and offers reliable, long-lasting corrosion protection, even when used outdoors. This ensures a long service life and resistance to weathering.

MECHANICAL PROPERTIES (S355 STEEL):

The steel used has a yield strength of 355 MPa, a tensile strength of 510–630 MPa, and a modulus of elasticity of 210,000 MPa. As a result, it offers high load-bearing capacity, dimensional stability, and durability for structural applications.

INSTALLATION PARAMETERS

The recommended tightening torque is between 200 and 450 Nm; the maximum permissible tightening torque is 600 Nm. The installation depth to the top of the head is variable.

ACCESSORIES (OPTIONAL)

The U post holder and the L-adapter Basic are available as accessories.

SAFETY & MAINTENANCE

An annual visual inspection is recommended. The load must not exceed the specified load-bearing capacity.

INSTALLATION INSTRUCTIONS

Vertical installation must be performed with a tolerance of $\pm 2^\circ$. A force-fit connection must be ensured. No stones larger than 50 mm are permitted in the upper embedding area. The use of a machine adapter is recommended.

ASSEMBLY

The choice of the appropriate installation method depends on the soil conditions and the length of the screw piles. Installation can be performed manually, using a hand-held electric screwdriver, or using a machine-driven hydraulic drive.

Manual installation using the Eurotec Ground Driver

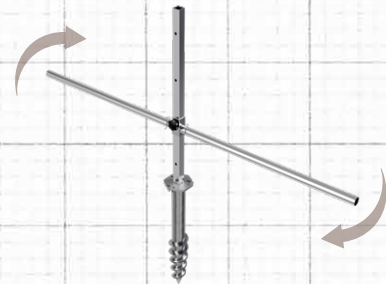

A method in which several people work together using a special turning tool. Each person pulls synchronously on one of the two handles until the foundation is fully screwed in.

Read more on page 22!

Hand-held electric screwdriver

A convenient, space-saving option for a single person. Ideal for tight workspaces and for screw foundations up to 2100 mm in length.

Hydraulic, machine-mounted rotary actuator

A professional installation solution for large-scale projects or challenging soil conditions. It ensures the safe and precise driving of even particularly long or heavy screw foundations – at low speed and high torque.



These AI-generated illustrations explain the operating principle and the different types of screw-in methods available.

- Left: Hand-held electric screwdriver
- Right: Hydraulic, machine-mounted drive

HOW TO CHOOSE THE RIGHT SCREW FOUNDATION

Screw foundations are classified by diameter and length to enable a precise selection for different soil conditions and load scenarios. Lengths starting at approximately 800 mm cover the required frost depth and structural requirements in many typical applications. Shorter versions still have their place — especially where shallower embedment depths are sufficient or where specific installation situations require a compact design.

The selection of the appropriate foundation geometry depends not only on the component to be installed later, but also on the interaction between the subgrade (e.g., soil class, compaction, moisture content) and the applied loads, such as dead loads, live loads, and wind loads. This allows for a structurally reliable solution tailored to the specific site conditions to be found for every project.

PRODUCT OVERVIEW

Pipe diameter [mm]	Nominal length [mm]	Internal thread	Building site	Windload
60	600	M12	medium soil	low
60	800	M12	medium soil	low
60	1000	M12	medium soil	low
76	800	M24	firm to medium soil	medium
76	1000	M24	middle layer of soil, no fill	medium
76	1300	M24	normal load-bearing soil	medium-high
76	1600	M24	normal load-bearing soil	high
76	2100	M24	soft soil, deep load-bearing layer	high
89	1600	M24	soft soil, deep load-bearing layer	high
89	2100	M24	soft to yielding soil	high
114	1600	M24	soft, slightly cohesive soil	high
114	2100	M24	soft ground, deep structure	very high

WINDLOAD

In this context, wind load refers not only to site-specific wind loads (see below), but also results from the interaction between the aerodynamic properties of the structure in question and the wind loads acting on it.

Wind load ranges in accordance with DIN EN 1991-1-4 (Eurocode 1)

- low: up to approx. 0.6 kN/m²
- average: 0.6–0.9 kN/m²
- high: 0.9–1.2 kN/m²
- very high: > 1.2 kN/m² (e.g., coastal areas, exposed locations)



SCREW FOUNDATIONS 60 SERIES

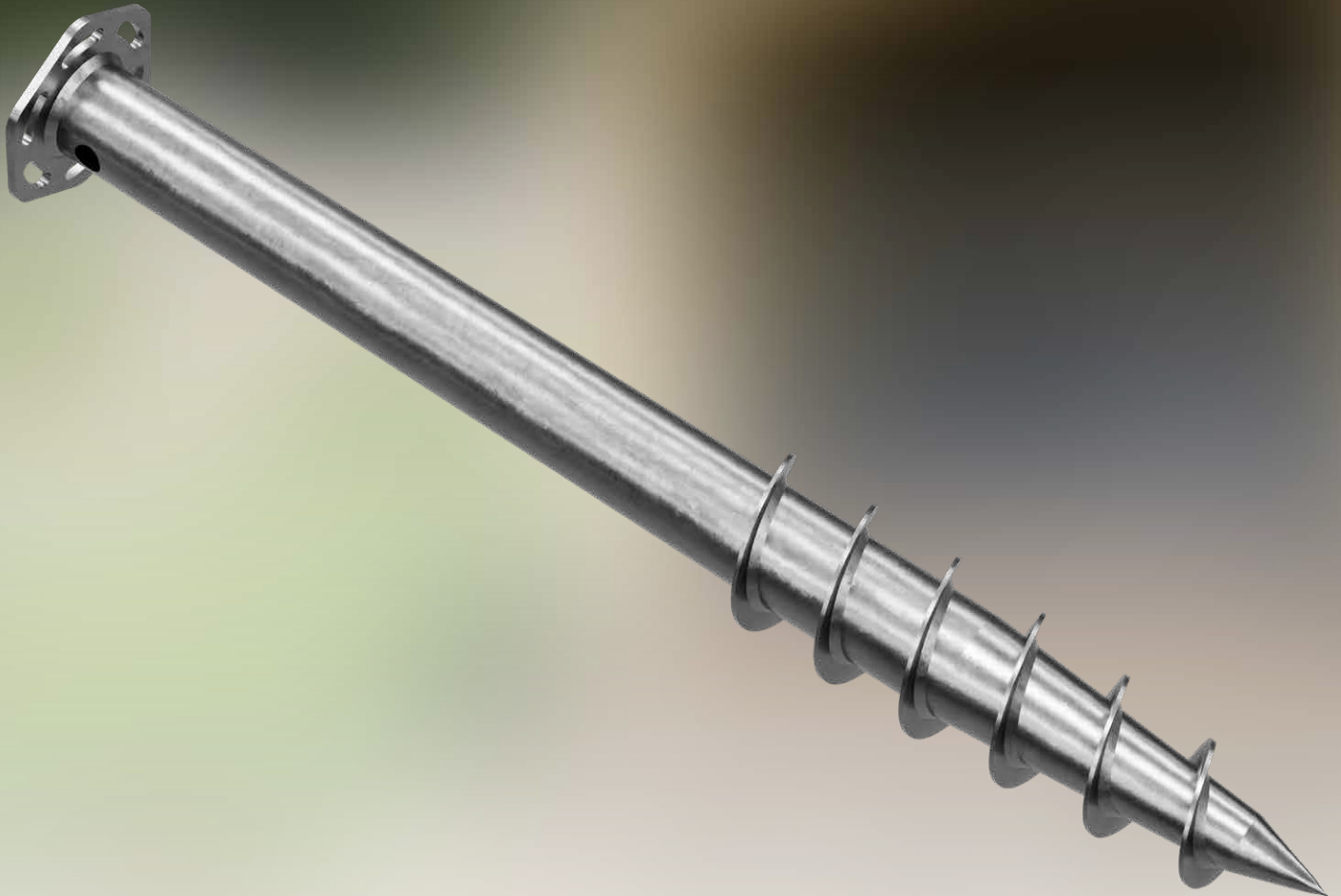

600 mm



800 mm



1000 mm

BEARING CAPACITY OF THE SUBGRADE (CHARACTERISTIC VALUE)

Soil type	Ø 60 x 600 mm		Ø 60 x 800 mm		Ø 60 x 1000 mm	
	Tensile force [kN]	Force [kN]	Tensile force [kN]	Force [kN]	Tensile force [kN]	Force [kN]
soft clay	0,1	0,2	0,2	0,3	0,2	0,4
medium-density clay	0,3	0,5	0,4	0,7	0,6	1,0
firm clay	0,5	0,9	0,8	1,3	1,0	1,7
Peat / organic soil	0,1	0,1	0,1	0,1	0,1	0,2
Fine sand (loose)	0,5	1,0	0,8	1,4	1,0	1,8
Fine sand (compacted)	1,0	1,9	1,4	2,6	1,9	3,3
Medium sand (loose)	0,7	1,3	1,0	1,8	1,3	2,4
Medium sand (dense)	1,3	2,4	1,8	3,3	2,3	4,2
Coarse sand (loose)	0,9	1,7	1,3	2,3	1,6	3,0
Coarse sand (dense)	1,8	3,3	2,5	4,6	3,3	5,9
Silt (soft)	0,3	0,6	0,5	0,8	0,6	1,1
Silt (compact)	0,6	1,1	0,8	1,5	1,1	2,0
Gravel (loose)	1,1	2,1	1,6	2,9	2,1	3,7
Gravel (compacted)	2,8	5,3	3,9	7,3	5,1	9,4
weathered rock / marl	1,5	2,8	2,2	3,9	2,9	5,1

All information is provided without warranty. The values listed apply to screw foundations that have been fully driven into the ground.

PRODUCT TABLE

Art. no.	Pipe diameter [mm]	Nominal length [mm]	Internal thread	Building site	Windload*	PU
100210	60	600	M12	medium soil	low	1
100211	60	800	M12	medium soil	low	1
100212	60	1000	M12	medium soil	low	1

*See windload, page 8

TECHNICAL DRAWING

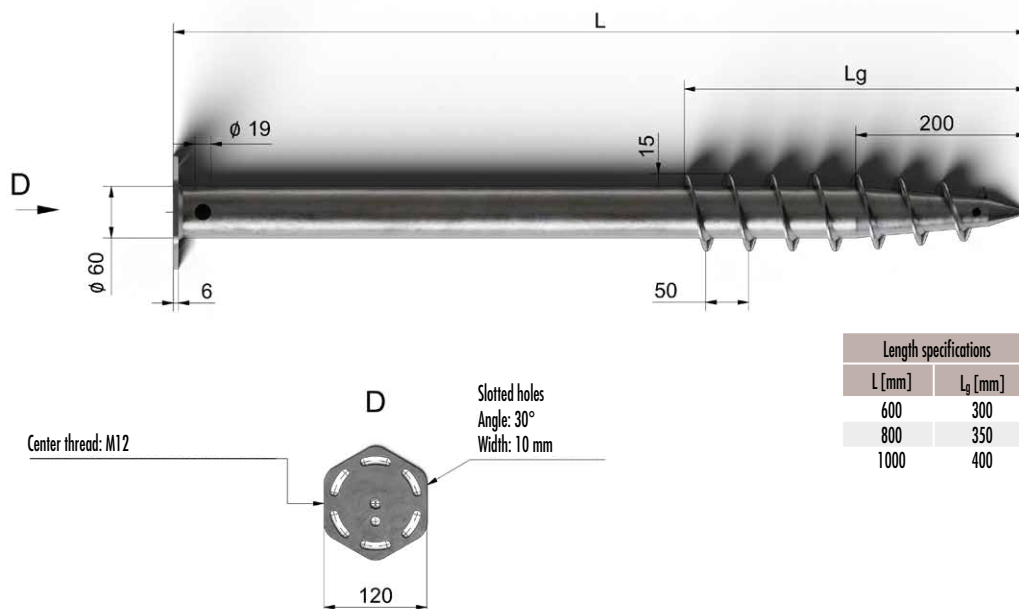

SCREW FOUNDATIONS 76 SERIES

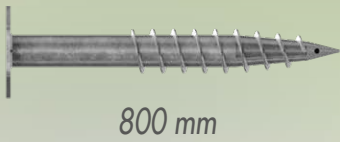

800 mm

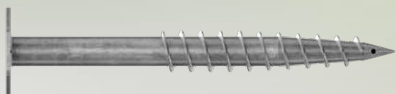

1000 mm



1300 mm

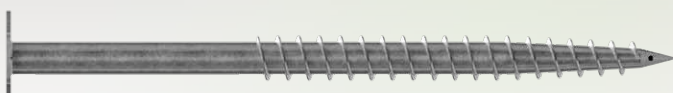

1600 mm

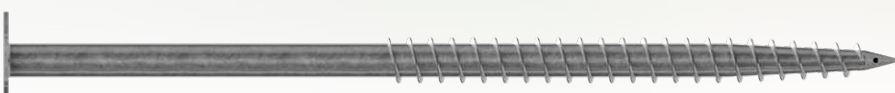

2100 mm

BEARING CAPACITY OF THE SUBGRADE (CHARACTERISTIC VALUE)

Soil type	Ø 76 x 800 mm		Ø 76 x 1000 mm		Ø 76 x 1300 mm		Ø 76 x 1600 mm		Ø 76 x 2100 mm	
	Tensile force [kN]	Force [kN]	Tensile force [kN]	Force [kN]	Tensile force [kN]	Force [kN]	Tensile force [kN]	Force [kN]	Tensile force [kN]	Force [kN]
soft clay	0,2	0,4	0,3	0,5	0,4	0,7	0,6	1,0	0,9	1,4
medium-density clay	0,6	1,0	0,8	1,3	1,2	1,9	1,6	2,5	2,4	3,7
firm clay	1,0	1,7	1,4	2,3	2,0	3,2	2,7	4,3	4,1	6,3
Peat / organic soil	0,1	0,2	0,1	0,2	0,2	0,3	0,2	0,4	0,4	0,6
Fine sand (loose)	1,0	1,9	1,3	2,4	1,9	3,3	2,5	4,2	3,6	6,0
Fine sand (compacted)	1,9	3,5	2,5	4,5	3,6	6,2	4,7	8,0	6,8	11,3
Medium sand (loose)	1,4	2,5	1,8	3,2	2,5	4,4	3,2	5,6	4,7	7,9
Medium sand (dense)	2,4	4,5	3,1	5,7	4,3	7,7	5,5	9,8	7,9	13,6
Coarse sand (loose)	1,7	3,2	2,2	4,1	3,1	5,5	4,0	7,1	5,7	9,8
Coarse sand (dense)	3,4	6,3	4,4	8,1	6,1	11,0	8,0	14,0	11,4	19,5
Silt (soft)	0,6	1,1	0,8	1,5	1,2	2,0	1,6	2,6	2,3	3,8
Silt (compact)	1,1	2,0	1,5	2,7	2,2	3,7	2,9	4,8	4,2	6,8
Gravel (loose)	2,1	4,0	2,8	5,1	3,9	6,9	5,1	8,9	7,3	12,4
Gravel (compacted)	5,4	10,1	6,9	12,9	9,5	17,3	12,2	21,9	17,3	30,3
weathered rock / marl	3,0	5,4	4,0	7,0	5,6	9,6	7,5	12,5	11,0	17,8

All information is provided without warranty. The values listed apply to screw foundations that have been fully driven into the ground.

PRODUCT TABLE

Art. no.	Pipe diameter [mm]	Nominal length [mm]	Internal thread	Building site	Windload*	PU
100213	76	800	M24	firm to medium soil	medium	1
100214	76	1000	M24	medium soil, no backfilling	medium	1
100215	76	1300	M24	normal load-bearing soil	medium-high	1
100216	76	1600	M24	normal load-bearing soil	high	1
100217	76	2100	M24	soft soil, deep load-bearing layer	high	1

*See windload, page 8

TECHNICAL DRAWING

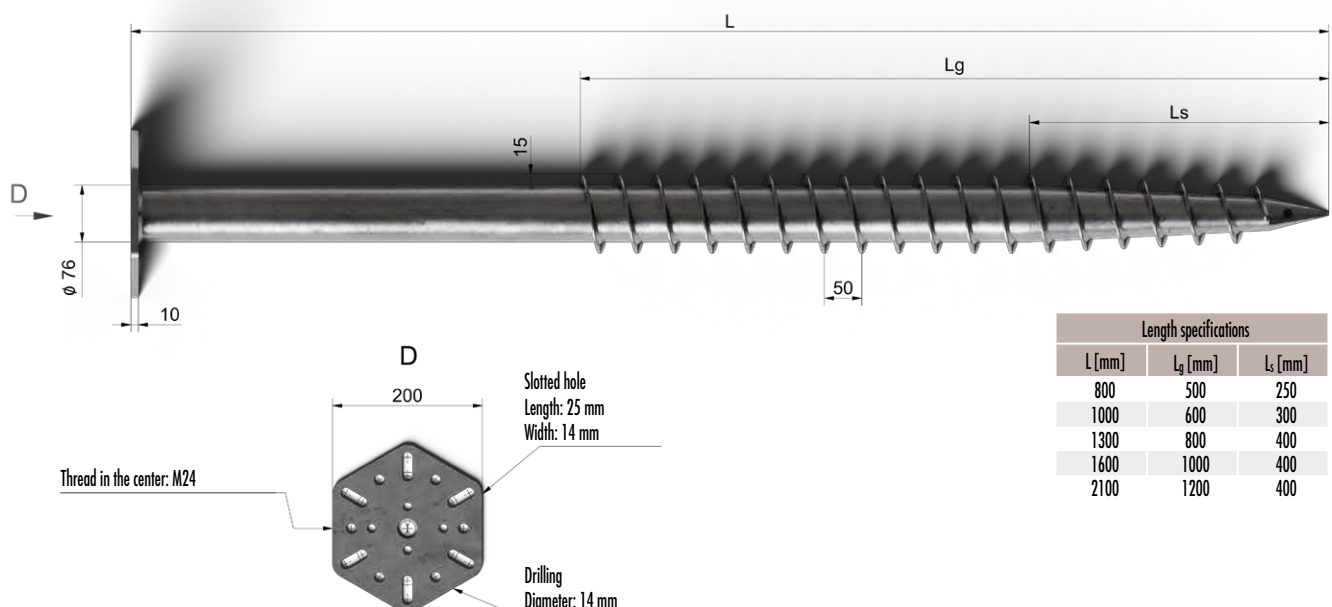

SCREW FOUNDATIONS 89 SERIES

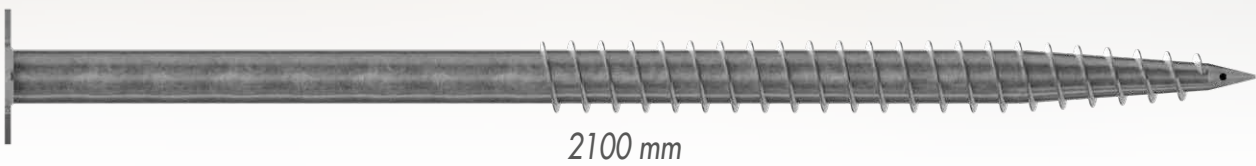
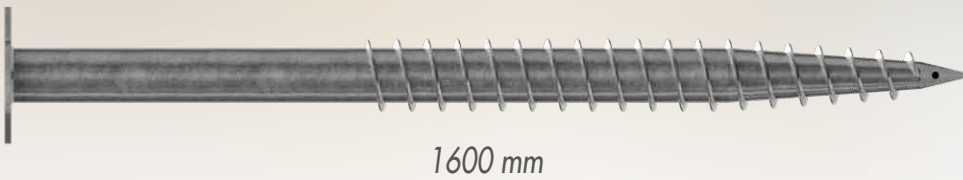
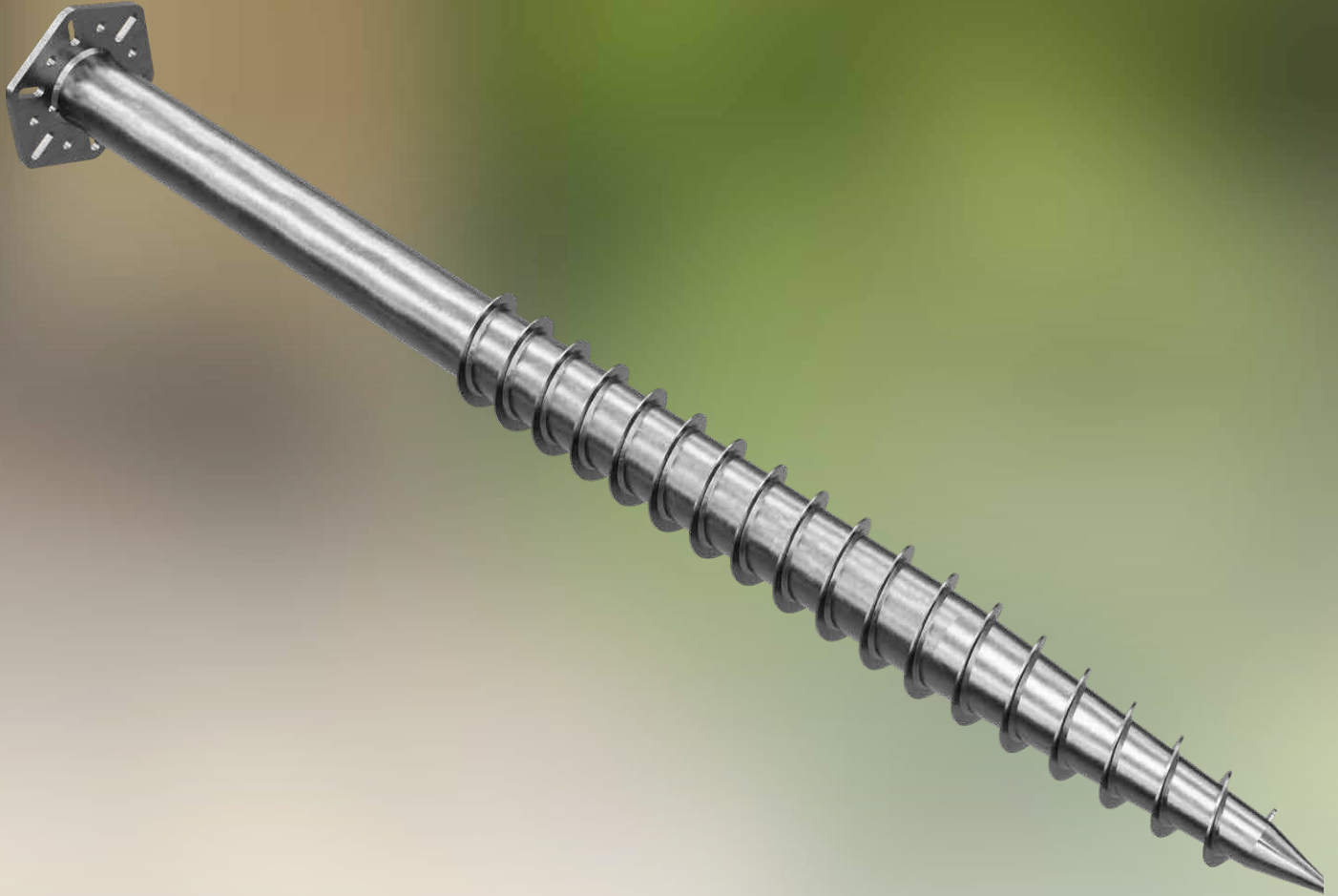

BEARING CAPACITY OF THE SUBGRADE (CHARACTERISTIC VALUE)

Soil type	Ø 89 x 1600 mm		Ø 89 x 2100 mm	
	Tensile force [kN]	Force [kN]	Tensile force [kN]	Force [kN]
soft clay	0,7	1,2	1,1	1,7
medium-density clay	1,9	3,1	2,9	4,5
firm clay	3,3	5,3	4,9	7,6
Peat / organic soil	0,3	0,5	0,5	0,7
Fine sand (loose)	3,0	5,2	4,4	7,4
Fine sand (compacted)	5,8	9,9	8,4	14,0
Medium sand (loose)	4,0	7,0	5,7	9,7
Medium sand (dense)	6,8	12,2	9,7	16,9
Coarse sand (loose)	5,0	8,8	7,1	12,2
Coarse sand (dense)	9,8	17,4	14,0	24,1
Silt (soft)	1,9	3,3	2,9	4,6
Silt (compact)	3,5	5,9	5,2	8,4
Gravel (loose)	6,3	11,0	9,0	15,3
Gravel (compacted)	15,2	27,3	21,4	37,6
weathered rock / marl	9,1	15,4	13,4	21,9

All information is provided without warranty. The values listed apply to screw foundations that have been fully driven into the ground.

PRODUCT TABLE

Art. no.	Pipe diameter [mm]	Nominal length [mm]	Internal thread	Building site	Windload*	PU
100218	89	1600	M24	soft ground, sand, fill material	high	1
100219	89	2100	M24	soft to yielding soil	high	1

*See windload, page 8

TECHNICAL DRAWING

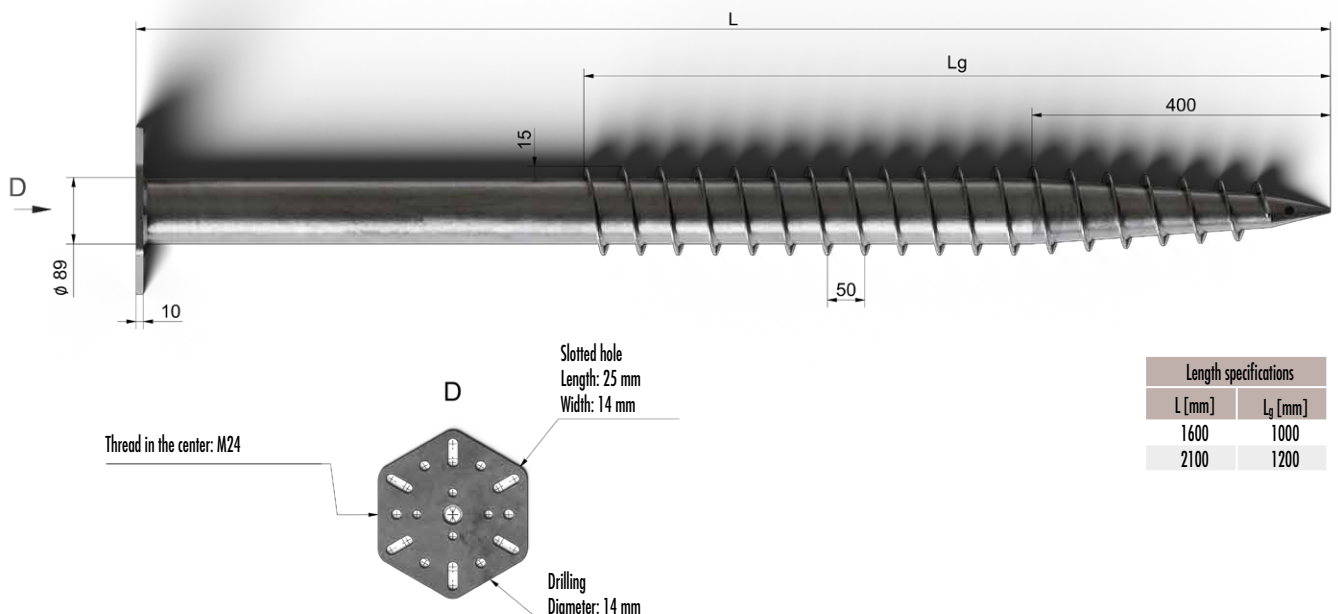

SCREW FOUNDATIONS

114 SERIES

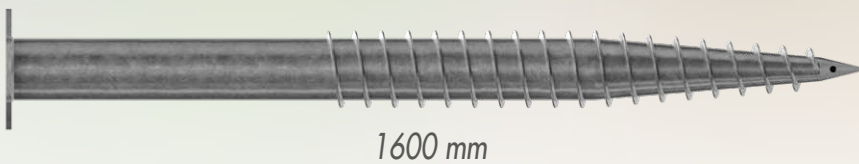
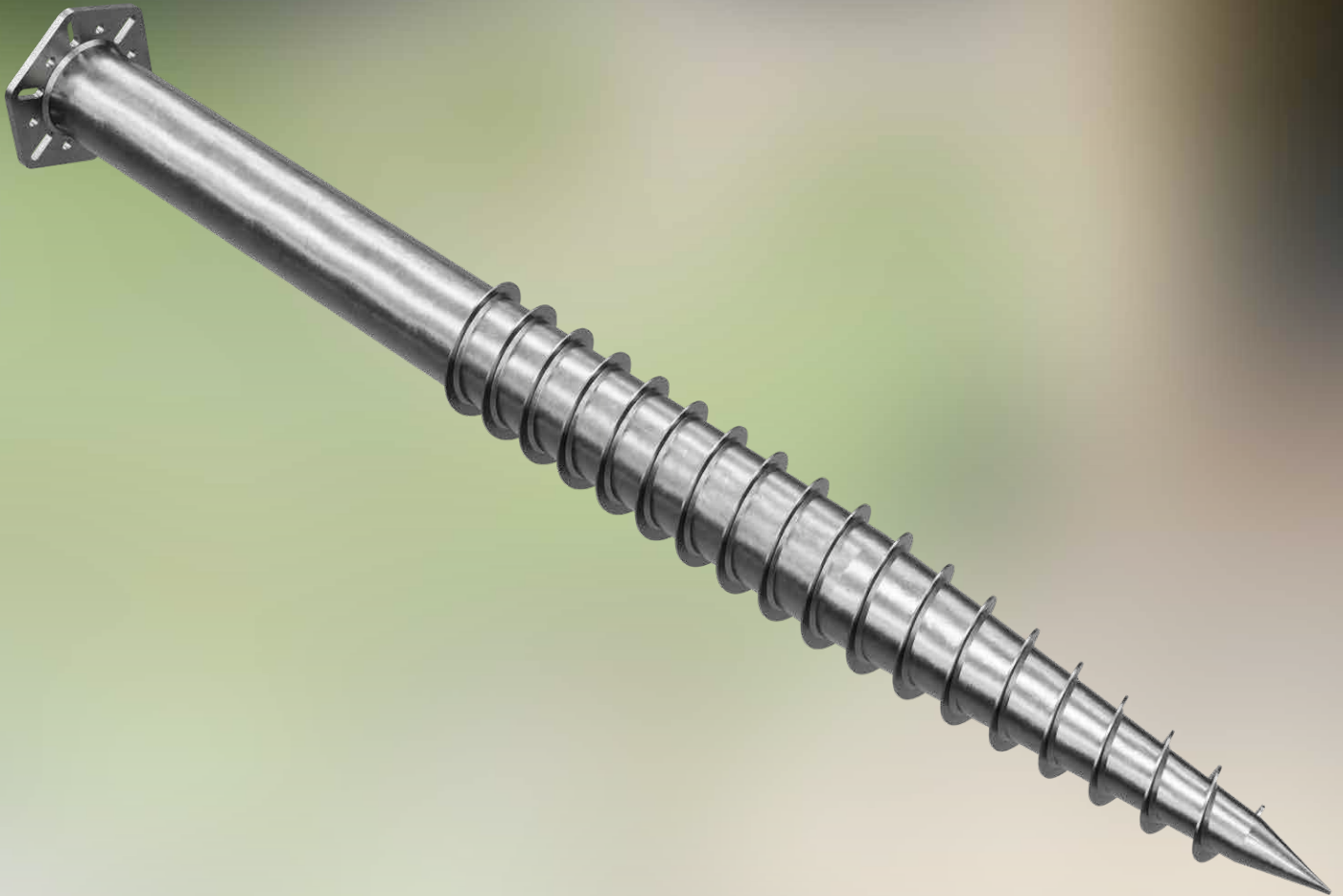

1600 mm

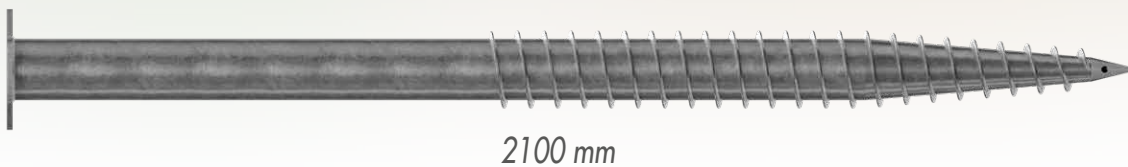

2100 mm

BEARING CAPACITY OF THE SUBGRADE (CHARACTERISTIC VALUE)

Soil type	Ø 114 x 1600 mm		Ø 114 x 2100 mm	
	Tensile force [kN]	Force [kN]	Tensile force [kN]	Force [kN]
soft clay	1,0	1,6	1,5	2,4
medium-density clay	2,7	4,3	4,0	6,2
firm clay	4,5	7,4	6,7	10,6
Peat / organic soil	0,4	0,7	0,6	1,0
Fine sand (loose)	4,3	7,5	6,1	10,4
Fine sand (compacted)	8,1	14,1	11,6	19,7
Medium sand (loose)	5,6	9,9	8,0	13,8
Medium sand (dense)	9,7	17,5	13,7	24,1
Coarse sand (loose)	7,0	12,6	9,9	17,4
Coarse sand (dense)	13,9	24,9	19,6	34,3
Silt (soft)	2,7	4,6	3,9	6,5
Silt (compact)	4,9	8,3	7,1	11,8
Gravel (loose)	8,8	15,7	12,5	21,8
Gravel (compacted)	21,5	39,2	30,2	53,7
weathered rock / marl	12,7	21,8	18,5	30,7

All information is provided without warranty. The values listed apply to screw foundations that have been fully driven into the ground.

PRODUCT TABLE

Art. no.	Pipe diameter [mm]	Nominal length [mm]	Internal thread	Building site	Windload*	PU
100220	114	1600	M24	soft, slightly cohesive soil	high	1
100221	114	2100	M24	soft ground, deep structure	very high	1

*See windload, page 8

TECHNICAL DRAWING

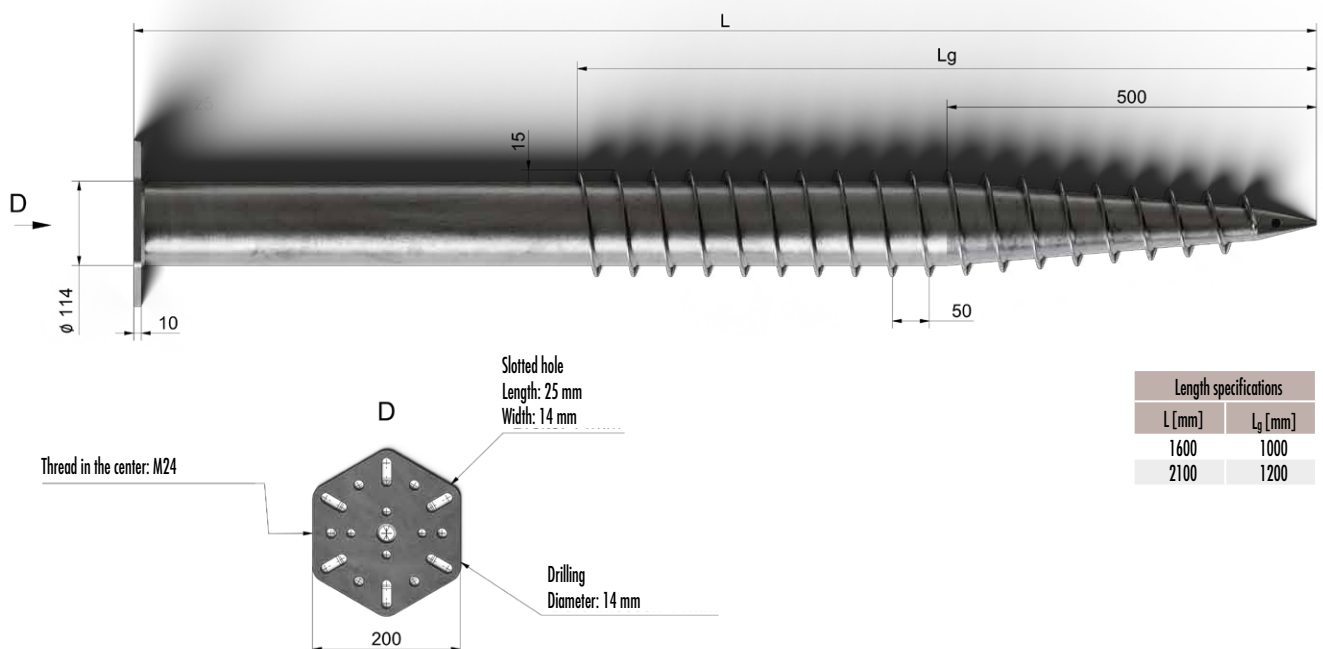

SCREW FOUNDATIONS

ACCESSORIES

L-ADAPTER BASIC

The Eurotec L-Adapter Basic serves as a connecting element between the screw foundation and the substructure. It is available in two versions: with an M12 threaded rod for the 60 series, and with an M24 threaded rod for the 76, 89, and 114 series.

Thanks to the adapter's 360° rotation, the substructure can be optimally positioned regardless of its orientation. After aligning the substructure on the base plate, the mounting arm can be flexibly adjusted to the specific position of the substructure, freely positioned, and then securely bolted in place.

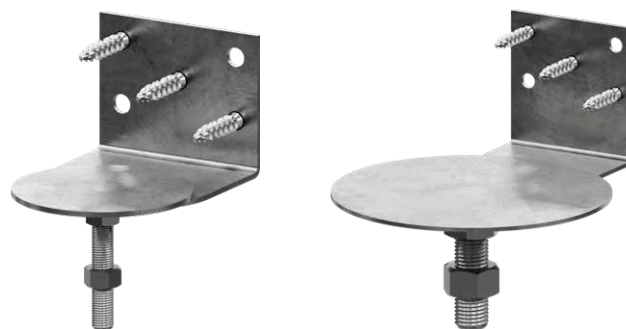

APPLICATIONS

- Photovoltaic mounting systems
- Outdoor structures
- Lightweight structures
- Custom outdoor structures

MATERIAL

- S235JR steel in accordance with EN 10025-2
- Hot-dip galvanized

FEATURES

- High installation flexibility thanks to 360° rotation
- Compatible with M12 and M24 bases
- Sturdy steel construction
- Easy on-site adjustment
- Screw-in connection via a threaded rod (M12 or M24, depending on the model)
- Suitable for custom system solutions
- Cost-effective solution

SAFETY INSTRUCTIONS

- Installation must be performed only by qualified professionals
- Use personal protective equipment
- Observe load limits
- Do not install any damaged components

DESIGN AND CONSTRUCTION

The L-adapter consists of an L-shaped steel profile with a welded or integrated threaded rod.

This design enables a load-bearing connection while offering high installation flexibility.

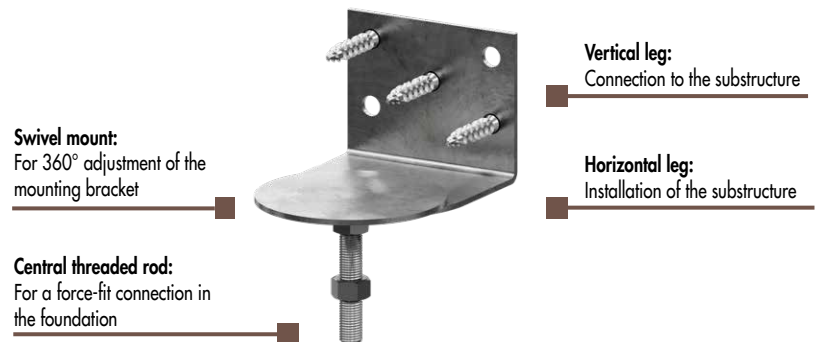

PRODUCT TABLE

Art. no.	Description	L ₁ (Height) [mm]	L ₂ (Width) [mm]	L ₃ (Depth) [mm]	Material thickness [mm]	Thread	Ø Plate [mm]	Drilling [mm]	Installation height [mm]	PU
800606	Basic 12	154	100	106	3	M12	100	5 x Ø 11	31–58	1
800607	Basic 24	194	200	206	3	M24	200	5 x Ø 11	50–75	1

MECHANICAL PROPERTIES

Parameter	Value
Yield strength R _e	≥ 235 MPa
Tensile strength R _m	360–510 MPa
Modulus of elasticity	ca. 210.000 MPa
Density	7,85 g/cm ³

INSTALLATION INSTRUCTIONS

1. Check that the screw foundation is properly seated and plumb.
2. Screw the threaded rod of the L-adapter into the female thread of the foundation.
3. Screw the adapter in to the desired height.
4. Secure the position with a lock nut.
5. Place the L-bracket against the wooden beam and secure it with a nut.
6. Screw the post connector screws into the designated holes to secure the substructure to the adapter.

U POST HOLDER

The U-shaped post holders made of hot-dip galvanized steel are ideal for securely fastening square timber posts. The side support keeps the timber post raised off the ground, which prevents waterlogging and extends the wood's lifespan. The installation is carried out securely via the $\varnothing 13.5$ hole in the base. Thanks to the hot-dip galvanization, the post holder is particularly corrosion-resistant and durable—perfect for use outdoors.



FEATURES

- Suitable for wooden posts in gardening and landscaping: Fences, privacy screens, pergolas, or carports
- Ensures the post is securely anchored and properly aligned
- Prevents the wood from coming into direct contact with the floor and reduces moisture damage
- Low-maintenance thanks to its weather-resistant surface

MATERIAL

- Steel, hot-dip galvanized

PRODUCT TABLE

Art. no.	Dimensions [mm]	PU
904717	71 x 150	1
904719	91 x 150	1
904721	101 x 150	1

TECHNICAL DRAWING

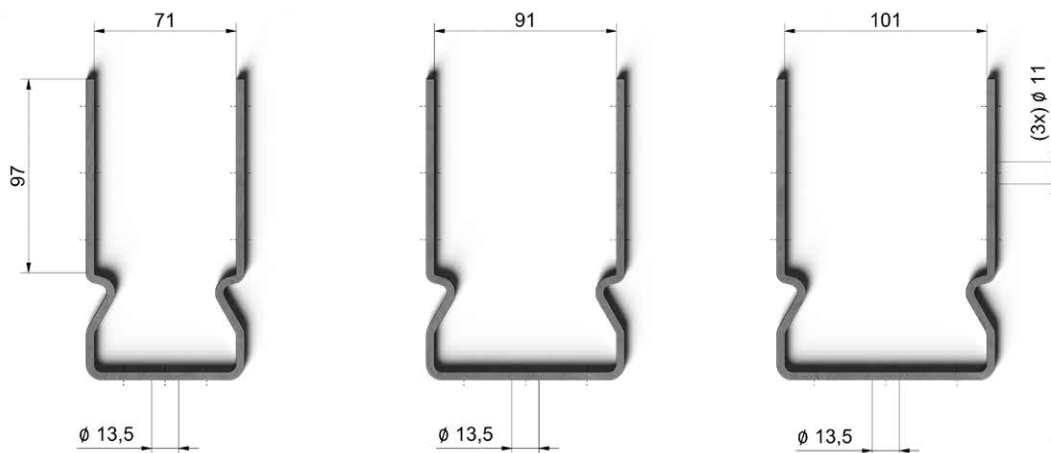

SOCKET ADAPTER

This adapter enables the mechanical installation of 60-series screw foundations using standard screw-driving machines. It is attached to the top of the screw foundation and allows torque to be transmitted via a socket (41 mm). The adapter is secured to the screw foundation with three screws and nuts, allowing it to be used safely by a single person.



FEATURES

- Enables automated screwdriving
- Reduced effort
- Can be installed by one person
- Precise grip thanks to a 3-point mounting system and a centering pin
- Compatible with the entire 60 series of screw foundations
- Adapter mount / connection: 41 mm socket
- **Mounting:**
 - 3 sets of bolts and nuts (with a bolt pattern compatible with the 60 series)
 - Min. motor power: 700 W

MATERIAL

- Steel

WHAT'S INCLUDED

- 1 x Socket adapter
- 3 x mounting screws
- 3 x nuts

OPERATING PRINCIPLE

1. Place the adapter on top of the 60 mm screw foundation.
2. Secure it using screws and nuts through the 3 holes.
3. Attach the 41-mm socket to the screwdriver.
4. Position the screwdriver and drive the foundation into place.
5. It is recommended that you check the alignment regularly.

PRODUCT TABLE

Art. no.	L ₁ (Height) [mm]	L ₂ (Width) [mm]	L ₃ (Depth) [mm]	Material thickness [mm]	Drilling [mm]	PU
800605	36	133	120	3,5	6 x Ø 10	1

GROUND DRIVER

Manual screw-in tool for 60 Series screw foundations

The Ground Driver manual screw-in tool was specifically designed for driving smaller screw foundations into the ground. It serves as a mechanical lever extension, allowing screw piles to be driven into the ground quickly, safely, and with minimal effort, without the need for power tools.

Thanks to its adjustable clamping height, pre-drilled positions, and robust steel construction, the tool is ideal for stress-free installation work in gardening, landscaping, and timber construction.



APPLICATIONS

This tool is suitable for manually setting:

- Screw foundations of the 60 series
- Foundations for light to medium-duty applications, such as deck substructures, fence posts, and light wood-frame structures.

MATERIAL

- Steel

OPERATING PRINCIPLE

1. Mounting

The base unit is secured to the flange of the bolted foundation using the three mounting screws provided.

2. Height adjustment

Thanks to several pre-drilled holes, the position of the terminal block can be adjusted to different screw-in heights.

3. Screwing in and out

Two people grasp the lever arms on either side and apply torque to the screw by turning them.

4. Management and Control

The tool allows for precise control over:

- Screw-in bracket
- Positioning
- Penetration depth

It allows for vertical, straight drilling, which is crucial for the stability of the final structure.

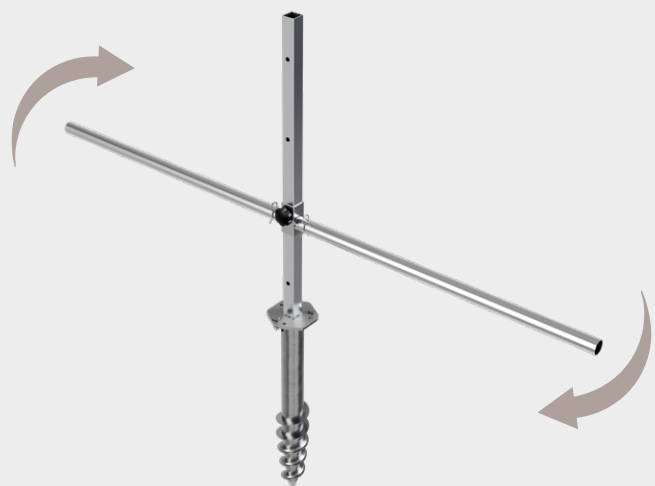

FEATURES

- Easy transport and quick setup thanks to the modular plug-in system.
- High leverage thanks to a 1.6-meter span
- Precise height and angle control
- No machinery required – ideal for remote or hard-to-reach construction sites.
- Sturdy steel construction for a long service life
- Mounted to the screw foundation using three screws and nuts.
- Two people are needed to install the screw foundation.

SAFETY INSTRUCTIONS

- The tool must be operated by two people at the same time.
- On rocky ground, pre-drilling or pilot drilling is recommended.
- Wear gloves to prevent slipping.

WHAT'S INCLUDED



PRODUCT TABLE

Assembled condition						
Art. no.	L ₁ (Height) [mm]	L ₂ (Width) [mm]	L ₃ (Depth) [mm]	Material thickness [mm]	Drilling [mm]	PU
800604	805	1650	133	2-3	6 x Ø 10	1

DIMENSIONS

Base body		
L ₁ (Height) [mm]	L ₂ (Width) [mm]	L ₃ (Depth) [mm]
803	120	133
Hebeladapter		
L ₁ (Height) [mm]	L ₂ (Width) [mm]	L ₃ (Depth) [mm]
80	640	48
Handpiece		
Outside-Ø [mm]	Inside-Ø [mm]	Length [mm]
35	31	800

SCREW-IN ROD

The screw-in rod is a sturdy hand tool designed for manually screwing in 60-series screw foundations. The bent end is inserted into the cross hole of the foundation and serves as a pivot point. The long rod section provides effective leverage and ensures precise, controlled installation even without mechanical assistance.

SPECIFICATIONS

- The bent end is inserted into the cross hole in the screw pile
- The long section of the rod acts as a lever for transmitting force
- The foundation is anchored in the ground through uniform rotational movements
- The ribbed profile ensures a secure grip and controlled handling

MATERIAL

- Galvanized, corrugated steel

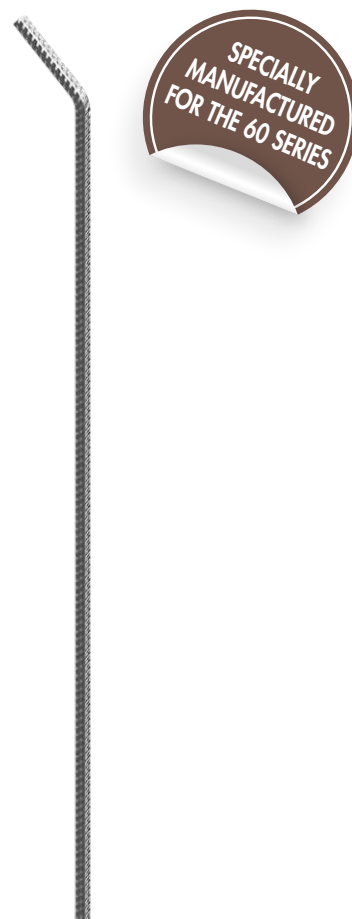

PRODUCT TABLE

Length [mm]	Diameter [mm]	Weight [kg]	PU
1000	Ø 16	1,33	1

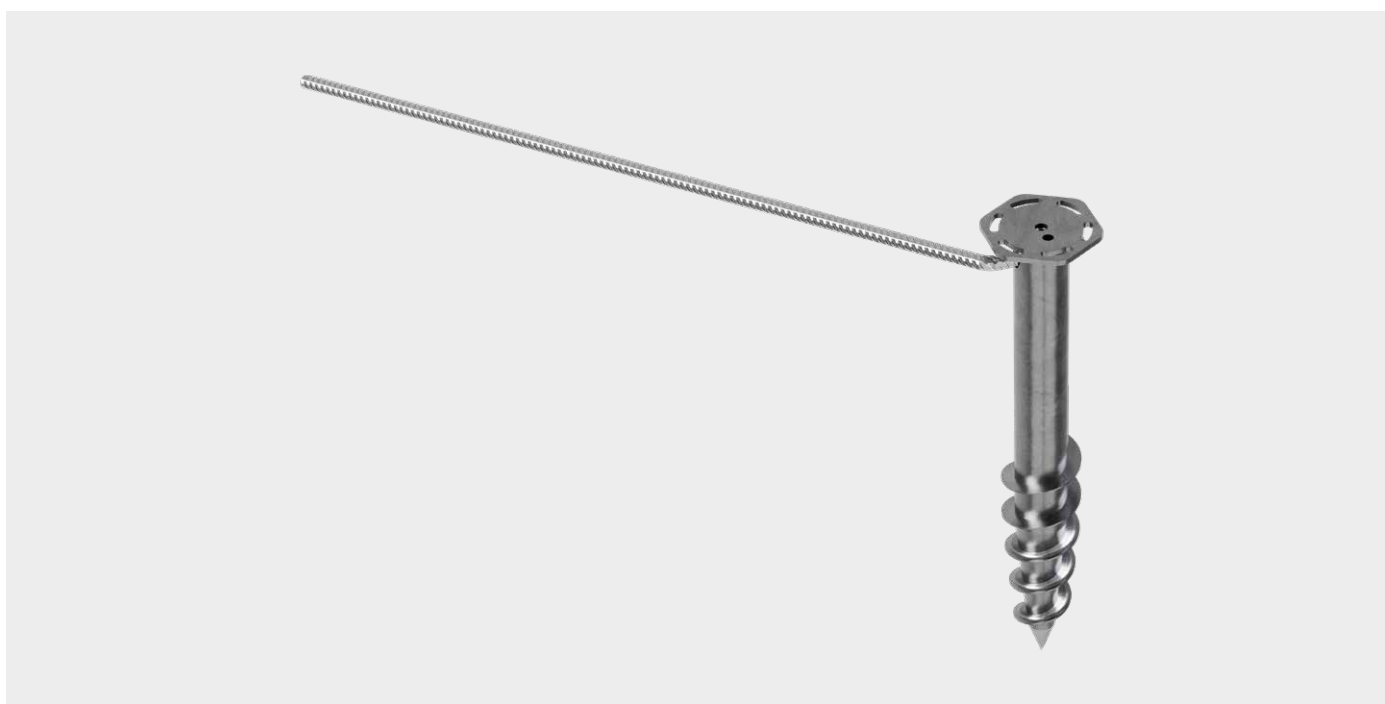

NOTES:

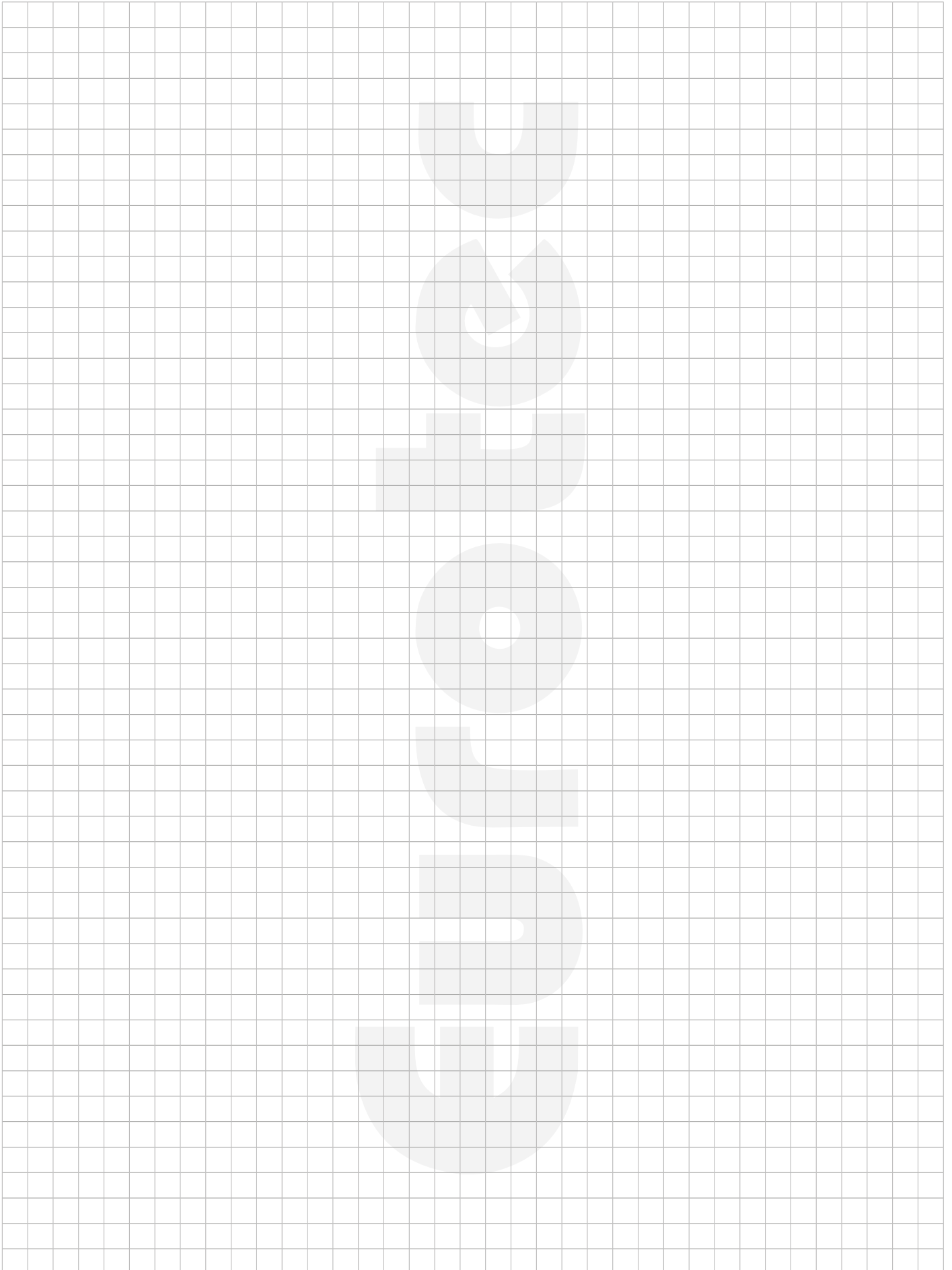

Eurotec[®]

The specialist for fastening technology

LEARN MORE ABOUT
OUR PRODUCT
RANGE:



E.u.o.Tec GmbH

Unter dem Hofe 5 – D-58099 Hagen

Tel. +49 2331 62 45-0

Fax +49 2331 62 45-200

E-Mail info@eurotec.team

www.eurotec.team/en

