

**Eurotec**<sup>®</sup>

The specialist for fastening technology

**OUR PRODUCT RANGE**

# **MASS TIMBER CONSTRUCTION**

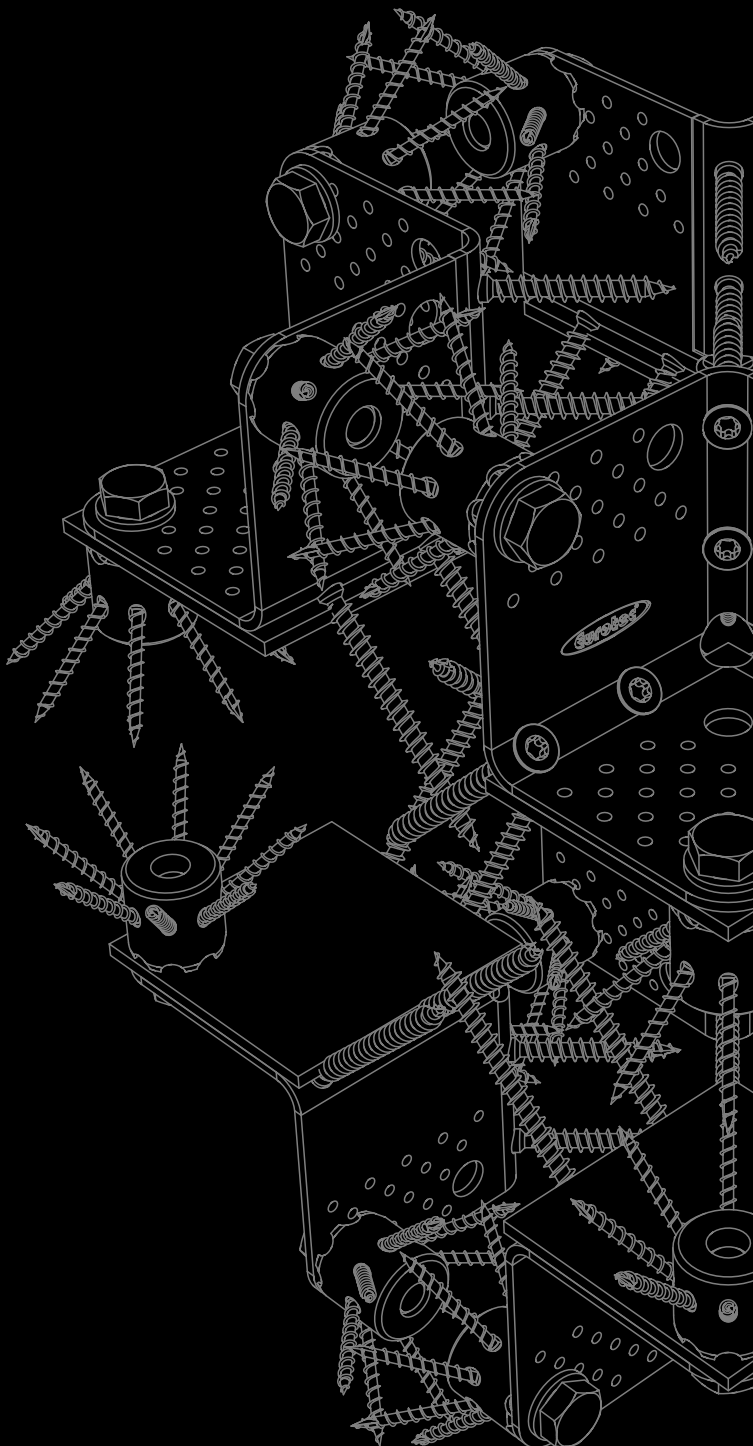

**TIMBER ENGINEERING**

---

**WOOD CONNECTORS**

---

**MASS TIMBER SCREWS**

---

**ECS SOFTWARE**

---

**BIM ONLINE PORTAL**

[www.eurotec.team/en](http://www.eurotec.team/en)



# CONTENTS

- CLT CONSTRUCTION ..... 10-13
- FOUNDATION CONNECTORS..... 18-29
- WALL AND FLOOR SYSTEMS..... 30-43
- POSTS ..... 44-49
- BEAMS ..... 50-59
- MASS TIMBER SCREWS..... 60-121
- LINKS TO RELATED BROCHURES..... 124
- INDEX ..... 125

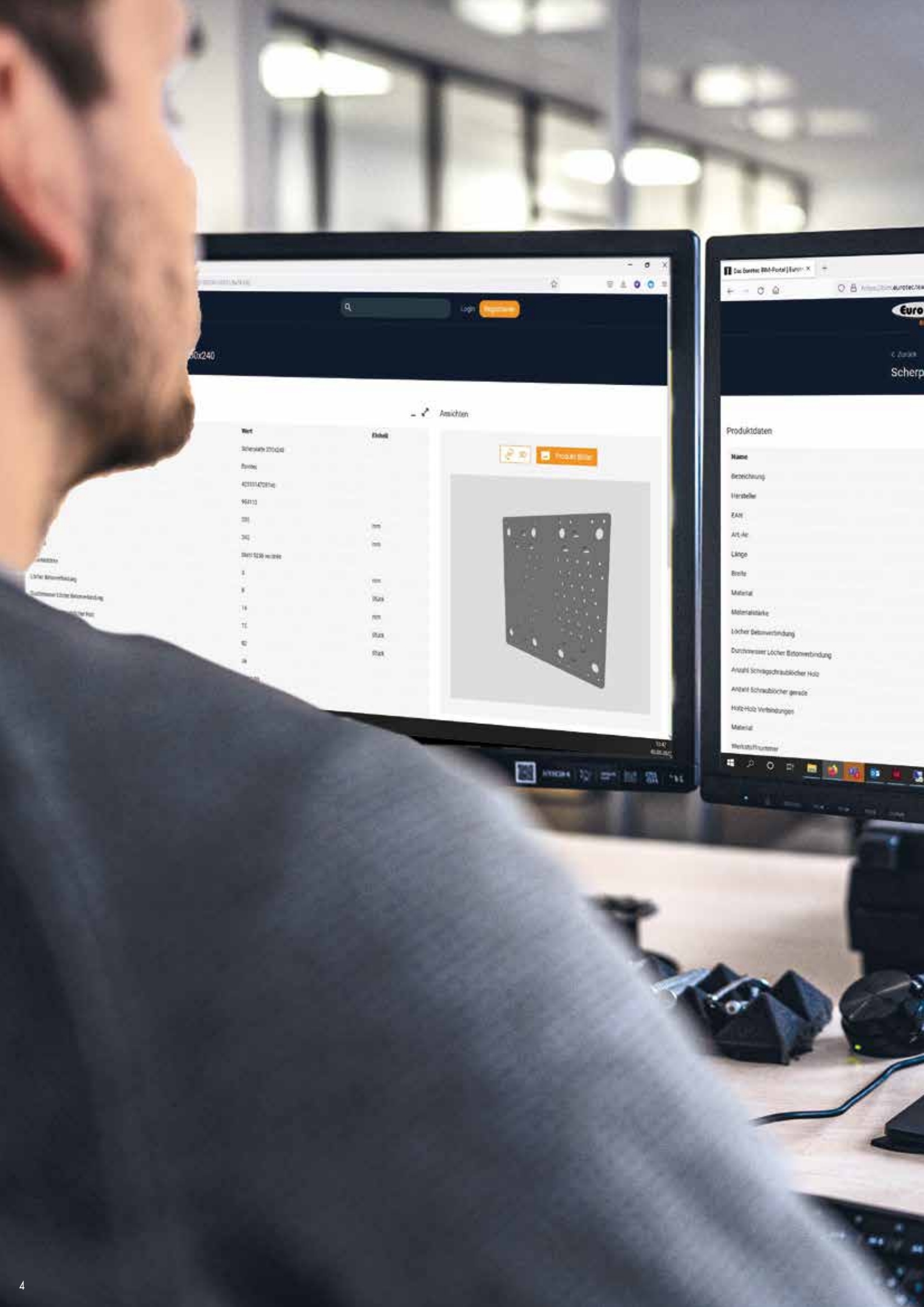

Suche  Login [Anmelden](#)

0x240

Ansichten

Wert	Einheit
30x40x2000	
30x40	
403331470116	
964110	
200	mm
340	mm
30x110x2000	
5	mm
8	mm
16	mm
25	mm
30	mm
38	mm

Produkt-Bilder

Das Beste BM-Portal | Euro X

Produktinformationen

Name

Bezeichnung

Hersteller

ZAH

Art-Nr

Länge

Breite

Material

Materialstärke

Löcher-Bohrverbindung

Durchmesser Löcher-Bohrverbindung

Anzahl Schweißnähten

Anzahl Schweißnähten gesamt

Holz-Holz-Verbindungen

Material

Werkstoffnummer

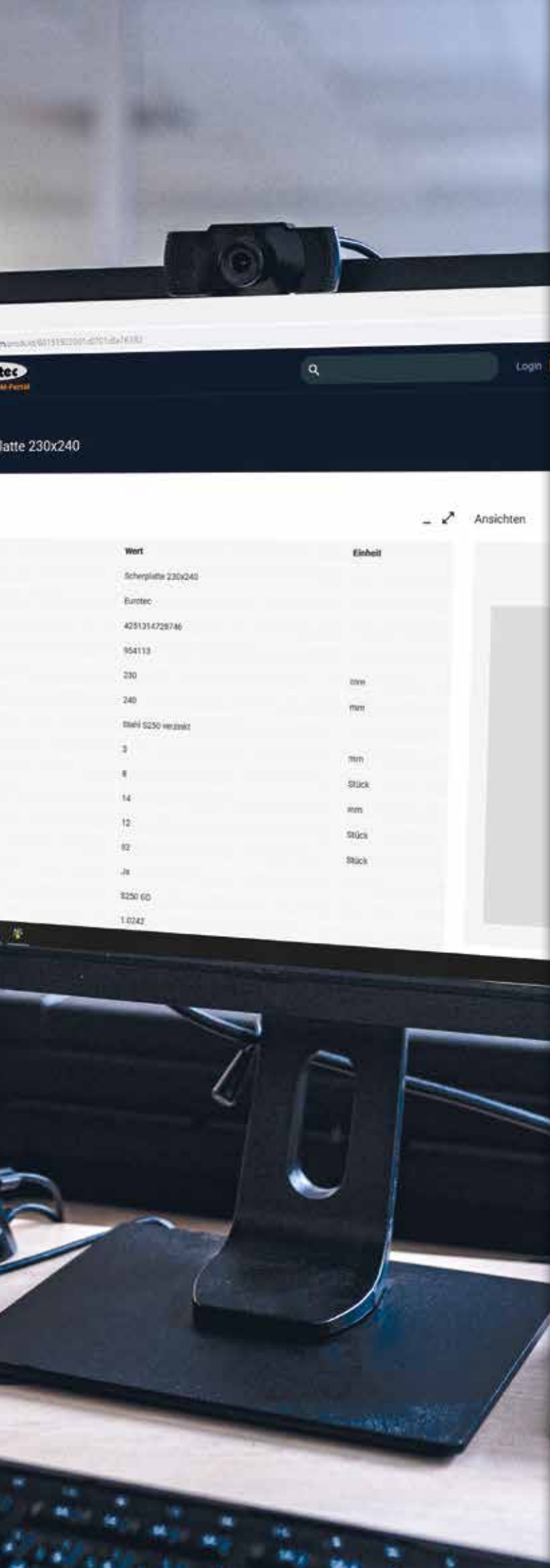

# OUR EUROTEC BIM-ONLINE- PORTAL

ALL DATA AT ONE SIGHT

## THE EUROTEC BIM PORTAL FOR YOUR CONSTRUCTION PLANNING!

**Building information modelling (BIM)** has become an indispensable part of modern planning. On our user-friendly platform, you will find product specifications as **BIM-enabled data** for use in your construction project. Some versatile file formats include 3D/CAD objects, DWG and PDF files, along with notes about our ETA certifications.

PLAN NOW  
[bim.eurotec.team](http://bim.eurotec.team)

# NEW MODULES IN OUR ECS SOFTWARE

Our ECS design software has been further developed in the course of a comprehensive revision and expansion. In particular, the focus was on the integration of modules for structural engineered wood constructions. The aim is to provide the user with effective tools to design standardized connections quickly and verifiably.

To learn more about ECS software,  
just scan the QR code.

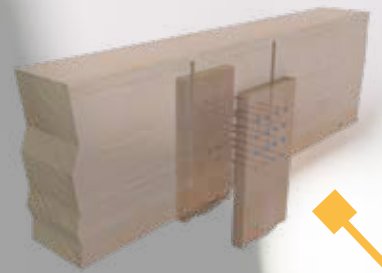

**LATERAL  
BUTT STRAP JOINT**

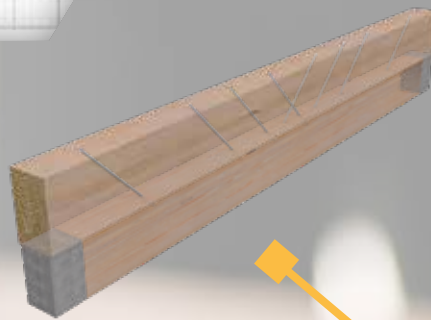

**JOIST DOUBLING**



**SUPPORT REINFORCEMENT**



**CROSS CONNECTION**

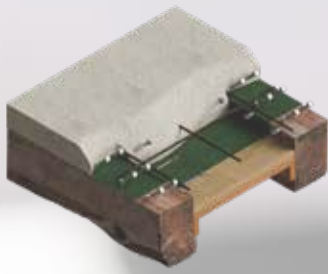

**TIMBER-CONCRETE  
CONNECTING**



**PARALLEL  
CONNECTION**



**MAIN-SECONDARY  
BEAM CONNECTION**



# LEARN MORE ABOUT OUR ECS SOFTWARE

The ECS software is a free, user-friendly software for the pre-dimensioning of Eurotec wood construction screws. The modules include main and secondary beam connections, transverse tension and transverse pressure reinforcements, rafter-purlin connections, fastenings for roofing and façade insulation systems and many other applications.

- The program gives you the option to fully customize your individual connection application by modifying parameters such as the geometry, material type (e.g. beech laminated veneer timber and solid timber in different strength classes), load sizes (variable and permanent loads), the load class and more to suit your needs.
- What's more, it makes it possible to optimize the fastening solution by adjusting the screw diameter and screw length as well as checking the strength utilization factor, which is shown in the lower right corner of the screen.
- Once you have selected the connection solution, a calculation report in accordance with ETA-11/0024 and EN 1995 (Eurocode 5) is available to you, including the corresponding drawings in PDF format.

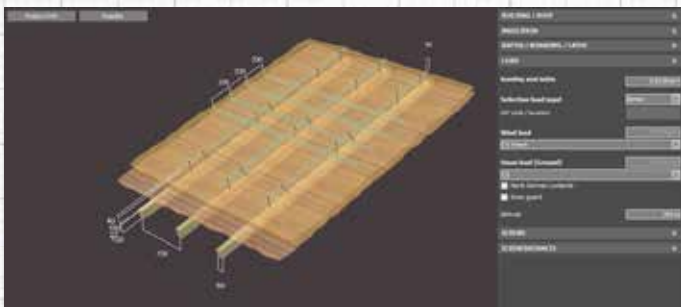
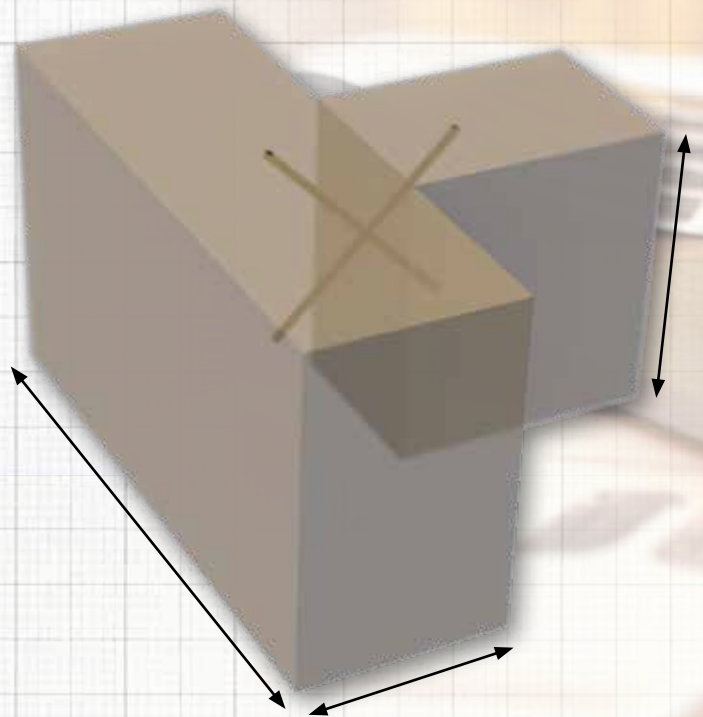
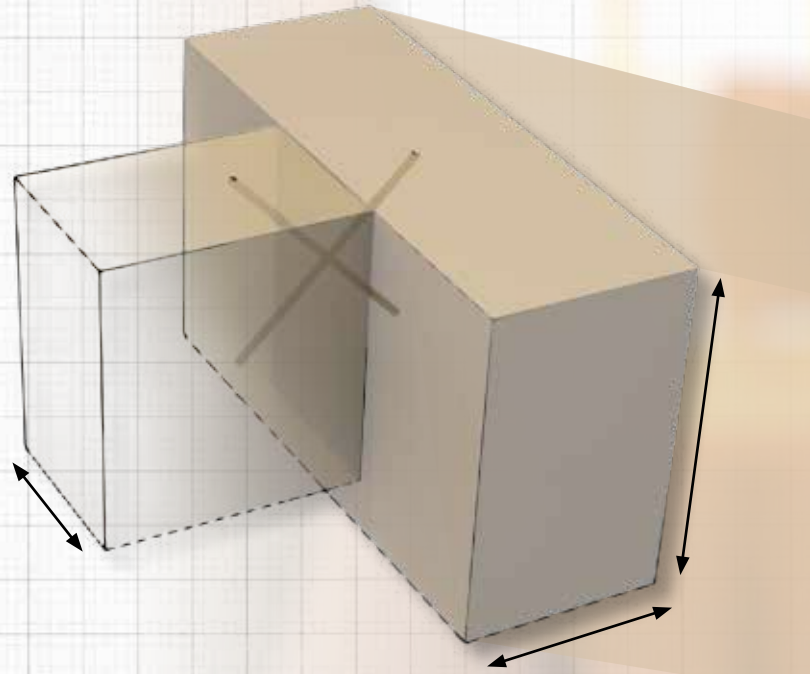

Module for the fastening of insulation materials on rafters using Topduo

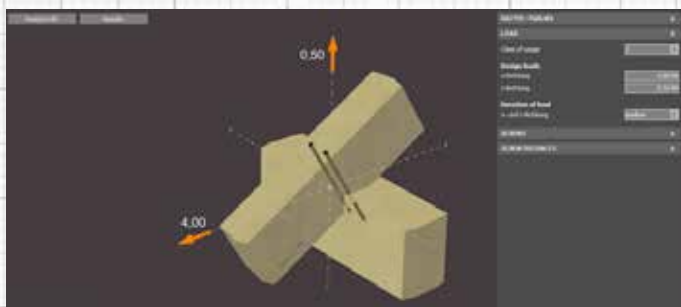

Module for rafter-purlin connections using Paneltwistec and KonstruX



SCAN NOW



DISCOVER  
THE ECS SOFTWARE!

## CLT BASICS

CLT (Cross-Laminated Timber) panels **consist of several layers of wooden boards** stacked crosswise (typically at an angle of 90°). They are glued together on their surfaces and sometimes on their edges (e.g., edge-glued CLT).

A cross-section of a CLT element **has at least three bonded sheet layers** arranged in an alternating way and **orthogonal to the adjacent layers**. In special configurations, successive layers can be arranged in the same direction, creating a double layer (for example, double longitudinal layers on the outer surfaces and/or additional double layers at the core of the panel) to achieve specific structural capacities.

CLT panels are typically manufactured with an **odd number of layers**. Gluing three to seven layers together is common. **The thickness of the individual layers of wood can vary from 20 mm to 40 mm, while the width can vary from about 60 mm to 240 mm.**

The panel sizes vary depending on the manufacturer. Typical CLT panel widths are 1.2 m, 2.4 m, and 3.0 m. Typical CLT thicknesses are between 60 mm and 320 mm; however, in special cases, the thickness can go up to 500 mm. The panel length can go up to 20 m; however, transport regulations may limit CLT panel sizes, with panel lengths typically restricted to a maximum of 13.5 m.

The timber in the outer layers of the CLT panels that are used as walls are aligned vertically, parallel to the gravity loads, to **maximize the vertical load capacity of the wall**. Similarly, in floor and roof systems, the outer layers run horizontally parallel to the main load bearing direction.

## ADVANTAGES OF BUILDING WITH CLT

- CLT allows screw connections in any direction because its cross-layered board structure eliminates the need to consider grain direction.
- Reduced construction time due to prefabrication of the elements
- Enables a breathable wall and floor system for timber buildings.
- CLT has both sound and heat insulating properties
- A wide range of architectural design flexibility
- All components of a house (walls, ceilings, and roof) can be made of CLT.
- Much lower weight compared to concrete and bricks
- No construction waste when demolishing buildings. CLT is completely ecologically recyclable and more.

## PRODUCTION OF CLT PANELS

1

The boards are sorted after the softwood boards have gone through a drying process (more than 48 hours). Growth deviations in the wood that would reduce the strength, or are simply unsightly, are marked. The sections that have such defects are cut out.

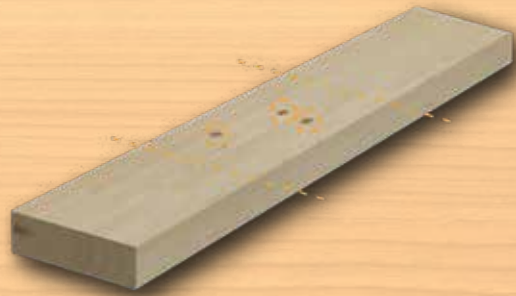

2

The boards of different lengths are joined together to create an almost endless strand of wooden boards, which is necessary for CLT production. This is done by means of finger joints. The resulting boards are then planed to eliminate thickness deviations between the boards.

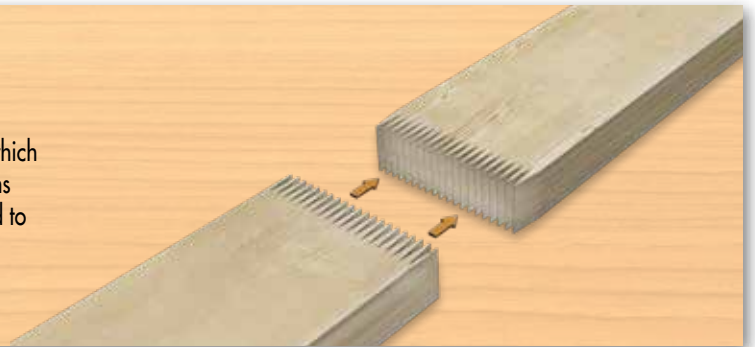

3

The manufactured boards are applied manually or mechanically to form a layer. Adhesive is applied to the resulting surface after a layer has been completely built. The most common method here is a glue curtain through the layer that is passed.

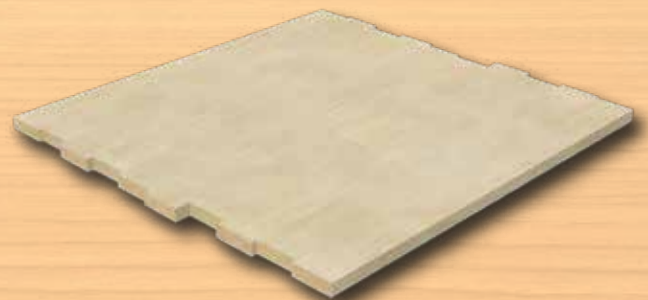

4

Another layer is placed on top of the glued-layer. This is aligned so that the fibre direction of the new layer runs at an angle of 90° to the fibres of the board below. Glue is then applied to the new layer. This process is repeated until the desired number of board layers is achieved.

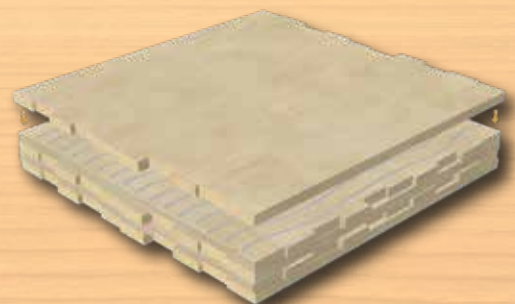

5

Once the desired number of layers is reached, the glued lamellas are pressed. The size of the press bed determines the possible panel size. As soon as the adhesive has cured, the CLT panel is re-processed to remove any dirt, adhesive residues, or protruding wood. This is done by planing and grinding the CLT panel.

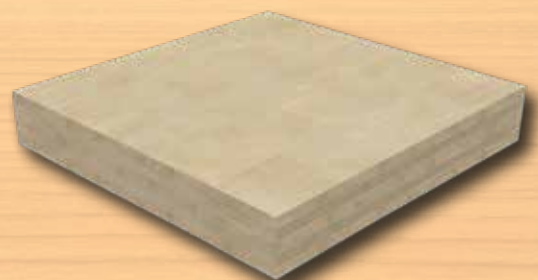



## BUILDING WITH CROSS-LAMINATED TIMBER

The construction phases of **modern timber construction methods**, such as building with cross-laminated timber, are **very different from that of the conventional solid construction method**. Whereas with solid construction most of the work takes place on the building site, with timber construction much of the work has now shifted from the construction site to the factory.

The keyword here is **prefabrication**. All wall, ceiling, and roof elements are not delivered to the construction site as raw, unprocessed CLT panels. Instead, they are pre-fabricated in off-site for direct assembly.

In the CNC off-site, the manufactured CLT mother panels are further processed into **individual elements**. All necessary work that is required on the construction site for fasteners of all kinds and/or for geometries that would be too difficult to realize on the construction site, is carried out here.

Common joinery work carried out in the factory includes:

- Windows and door cut-outs
- Angled cuts in the gable area
- Joint cuts and notches
- Milling of folding systems (for example: joint deck board fold, tier fold)
- Special geometries for special connectors
- Special transportation strips might be left out to allow safer transportation and installation of individual components

Such **complex processing steps**, especially through the use of computer-controlled processing machines, **increase the amount of upfront planning work**. Positions for connectors and installations within the house (electrical/water) must be provided with the necessary information. Furthermore, care is taken to ensure that **all components are matched to each other to the millimetre** in the final assembly, so that there are no problems during the installation.

**MASS TIMBER CONNECTORS:**

**SHEARING  
ANGLES**



**ANGLE  
BRACKET**



**CLT  
BRACKET**



**SHEARING  
PLATES**



**TENSION  
STRAPS**



**TENSION  
RODS**



**SIMPLY  
TIE BAR**



**CLT SYSTEM  
ANGLES**



**PEDIX POST FEET**



**STRUCTUS**



**MASS TIMBER CONNECTORS:**

**STRUCTUS  
BASE**



**MAGNUS HOOK  
CONNECTORS**



**T-PROFILE  
SYSTEM**



**CONNECTO**



**IDEEFIX**



**JOIST  
HANGERS**

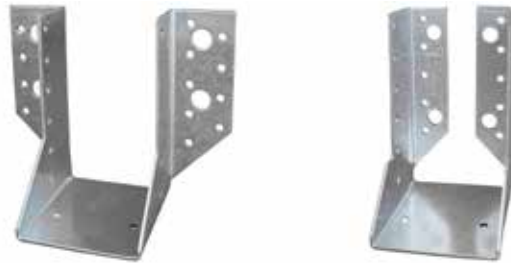

**ECKTEC**



**MASS  
TIMBER  
SCREWS**



# FOUNDATION CONNECTORS

# 1





## 1.1 ANGLES:

### 1.1.1 SHEARING ANGLE

Used to absorb shear and tension forces that was specifically developed for modern timber construction. Various holes for anchoring in wood and concrete mean that our shearing angle is used in timber frame and CLT construction. It is used with Shearing Angle Pressure Plate for connecting to concrete slabs and could reach 47.9 kN of shear capacity.









Art. no.	Dimensions [mm]	Material	Material thickness [mm]	PU
954112	230 x 120	S250 galvanised	3	1

#### DIMENSIONS OF THE PRESSURE PLATE

Art. no.	Dimensions [mm]	Material	Material thickness [mm]	PU
954111	230 x 68	S235 galvanised	12	1

#### FASTENERS AND ADDITIONS:

Type	Description	Illustration
Angle bracket screws (ABS)	Plate screw, Ø 5 mm	
Bolt anchors Ø 12 mm	Torque-controlled expanding plug	
Rock concrete screw Ø 12,5 mm	Durable concrete anchoring screw	
Panelwister	Wood construction screw ø5 x 120 mm	
Anchor nails	Ring shank nail, Ø 4 mm	
Pressure plate	Works in combination with a shear angle to absorb additional tensile forces	

#### APPLICATION IMAGE





## 1.1.2 HB FLAT SHEARING ANGLE

The HB Flat shearing Angle (wood-concrete) is a bracket connector for absorbing shear and tension forces that was specifically developed for modern CLT construction. Its low height means it is ideally suited to use in timber frame construction. The pressure plate allows to carry uplift forces to be optimally conducted into the concrete. For concrete, it could reach 40 kN and a tension capacity of 30 kN.

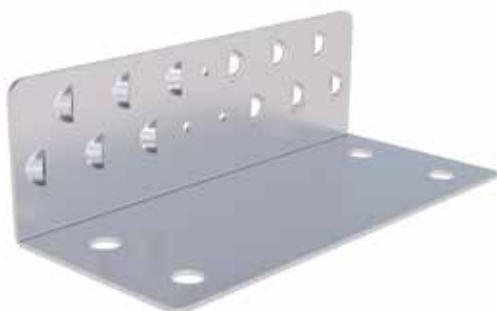

Art. no.	Dimensions [mm]	Material	Material thickness [mm]	PU
954087	230 x 100	S250 galvanised	3	1

### DIMENSIONS OF THE PRESSURE PLATE

Art. no.	Dimensions [mm]	Material	Material thickness [mm]	PU
954111	230 x 68	S235 galvanised	12	1

### FASTENERS AND ADDITIONS:

Type	Description	Illustration
Angle bracket screws (ABS)	Plate screw, Ø 5 mm	
Bolt anchors Ø 12 mm	Torque-controlled expanding plug	
Rock concrete screw Ø 12,5 mm	Durable concrete anchoring screw	
Panelwistec	Wood construction screw ø5 x 120 mm	
Pressure plate	Works in combination with a shear angle to absorb additional tensile forces	

### APPLICATION IMAGE



### 1.1.3. ANGLE-BRACKET WITH A RIB

The Angle bracket with a rib comes in four different dimensions. The connector 's stability, provided by the reinforcement bead, allows connections with shear capacities.



Art. no.	Dimensions [mm]	Material	Material thickness [mm]	PU
904725	70 x 70	S 250 GD +Z 275	2	100
904726	90 x 90	S 250 GD +Z 275	2,5	100
904727	100 x 100	S 250 GD +Z 275	3	50
904729	110 x 170	S 250 GD +Z 275	3	25

#### FASTENERS:

Type	Description	Illustration
Angle bracket screws (ABS)	Plate screw, Ø 5 mm	
Bolt anchors	Torque-controlled expanding plug	
Rock concrete screw	Durable concrete anchoring screw	

#### APPLICATION IMAGE



## 1.1.4 CLT BRACKET

CLT brackets offer both wood-concrete and wood-wood connections for absorbing shear and uplift forces. They are specifically developed for CLT structures; however, they can also be used in timber frame construction.



Art. no.	Dimensions [mm]	Material	Material thickness [mm]	PU
954236	110 x 105 x 6	S250 galvanised	2,5	1
954233	110 x 170 x 115	S250 galvanised	2,5	1
954235	150 x 70 x 50	S250 galvanised	2,5	1

### FASTENERS:

Type	Description	Illustration
Angle bracket screws (ABS)	Plate screw, Ø 5 mm	
Bolt anchors Ø 12 mm	Torque-controlled expansion anchors	
Rock concrete screw Ø 12,5 mm	Durable concrete anchoring screw	
Anchor nails	Ring shank nail, Ø 4 mm	

### APPLICATION IMAGE



## 1.2 PLATES:

### 1.2.1 SHEARING PLATE

The Shearing Plate is a plate connector for absorbing shear and tension forces that was specifically developed for modern timber construction. In the case of connecting to concrete, the shear and tension capacities could reach up to 47.9 kN and 116 kN, respectively.



Art. no.	Dimensions [mm]	Material	Material thickness [mm]	PU
954113	230 x 240	S250 galvanised	3	1

#### FASTENERS:

Type	Description	Illustration
Angle bracket screws (ABS)	Plate screw, Ø 5 mm	
Bolt anchors Ø 12 mm	Torque-controlled expanding plug	
Rock concrete screw Ø 12,5 mm	Durable concrete anchoring screw	
Anchor nails	Ring shank nail, Ø 4 mm	

#### APPLICATION IMAGE

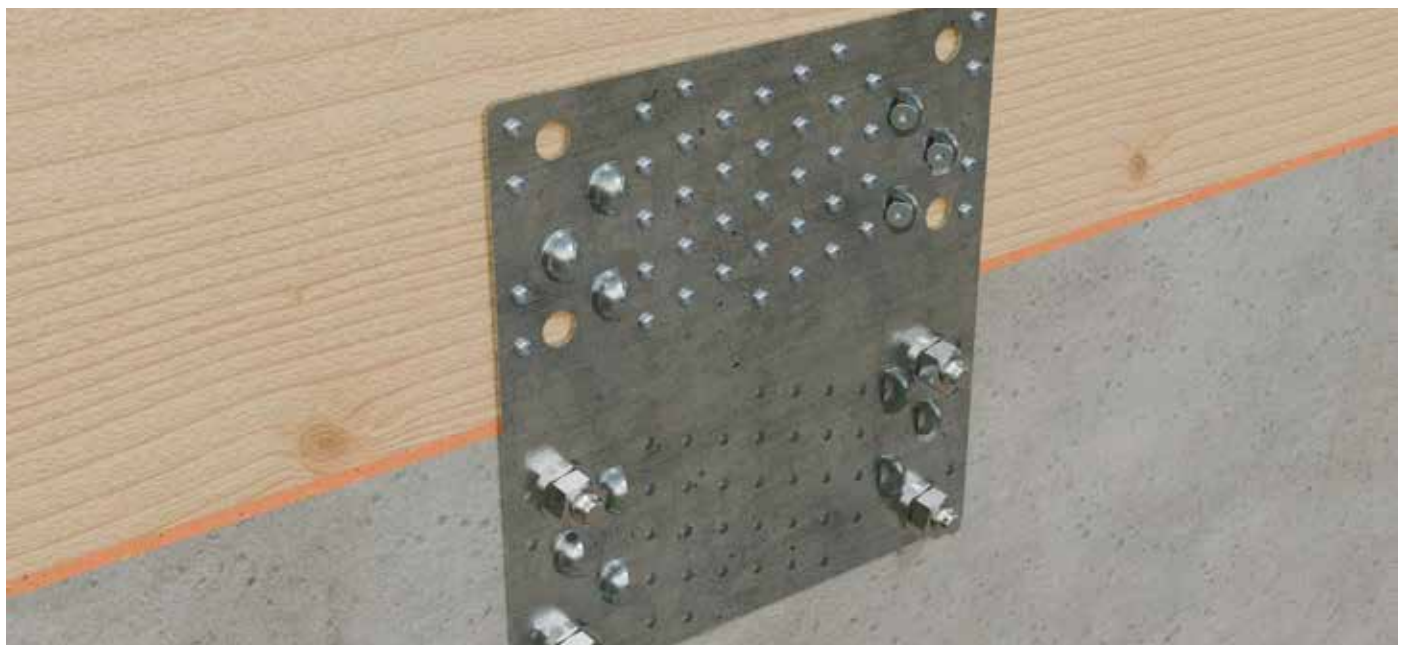



## 1.2.2 TENSION STRAP HB

The Tension Strap HB is designed for absorbing tensile forces developed for modern timber construction. It is used for connections between wood and concrete. Its tension capacity could reach up to 38 kN.



Art. no.	Dimensions [mm]	Material	Material thickness [mm]	PU
954095	506 x 60	S250 galvanised	3	1
954097	506 x 70	S250 galvanised	3	1

### FASTENERS:

Type	Description	Illustration
Paneltwister	Wood construction screw ø5 x 120 mm	
Bolt anchors Ø 12 mm	Torque-controlled expanding plug	
Rock concrete screw Ø 12,5 mm	Durable concrete anchoring screw	
Angle bracket screws (ABS)	Plate screw, Ø 5 mm	

### APPLICATION IMAGE



## 1.3 HOLD DOWNS:



### 1.3.1 TENSION-RODS

The Tension rod 340/440/540/620 are moulded sheet steel parts especially for CLT construction for transfer of tensile forces. They enable quick and easy base point anchoring of wooden elements in wood, steel or concrete substrates.



Art. no.	Dimensions [mm]	Material	Material thickness [mm]	PU
954099	340 x 63	S355 galvanized	3	1
954100	440 x 63	S355 galvanized	3	1
954231	540 x 63	S355 galvanized	3	1
954232	620 x 83	S355 galvanized	3	1

#### FASTENERS:

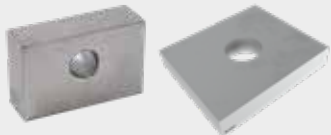
Type	Description	Illustration
Angle bracket screws (ABS)	Plate screw, Ø 5 mm	
Threaded rod	With hex nut and washer	
Anchor nails	Ring shank nail, Ø 4 mm	
Pressure plates	The tensile force can be increased in combination with the pressure plate	

#### APPLICATION IMAGE







## 1.3.2 TENSION ROD HIGHLOAD

The tension rod HighLoad is specially designed for the transmission of the enormously high tensile forces found in CLT constructions. It was developed to meet the requirements of modern multi-storey timber buildings.



Art. no.	Dimensions [mm]	Material	Material thickness [mm]	PU
954114	750 x 140 x 85	S355 galvanised	3	1

### FASTENERS:

Type	Description	Illustration
Angle bracket screws (ABS)	Plate screw, Ø 5 mm	
Threaded rod M27	With hex nut and washer	
Anchor nails	Ring shank nail, Ø 4 mm	
Pressure plate	The tensile force can be increased in combination with the pressure plate	

### APPLICATION IMAGE







### 1.3.3 SIMPLY TIE-BAR

The Simply tie bar allows quick and easy timber-timber, timber-concrete, timber-steel and timber-brickwork connections. It can withstand moderate tension loads. The Simply tie bar has nail/screw holes on the vertical side and anchor holes (including a slot) in the other.



Art. no.	Dimensions [mm]	Material	Material thickness [mm]	PU
954056	95 x 88	S235JR galvanized	4	25
954057	135 x 88	S235JR galvanized	4	25
954058	285 x 88	S235JR galvanized	4	25

#### FASTENERS:

Type	Description	Illustration
Angle bracket screws (ABS)	Plate screw, Ø 5 mm	
Bolt anchors Ø 12 mm	Torque-controlled expanding plug	
Anchor nails	Ring shank nail, Ø 4 mm	
Threaded rod	With hex nut and washer	

#### APPLICATION IMAGE



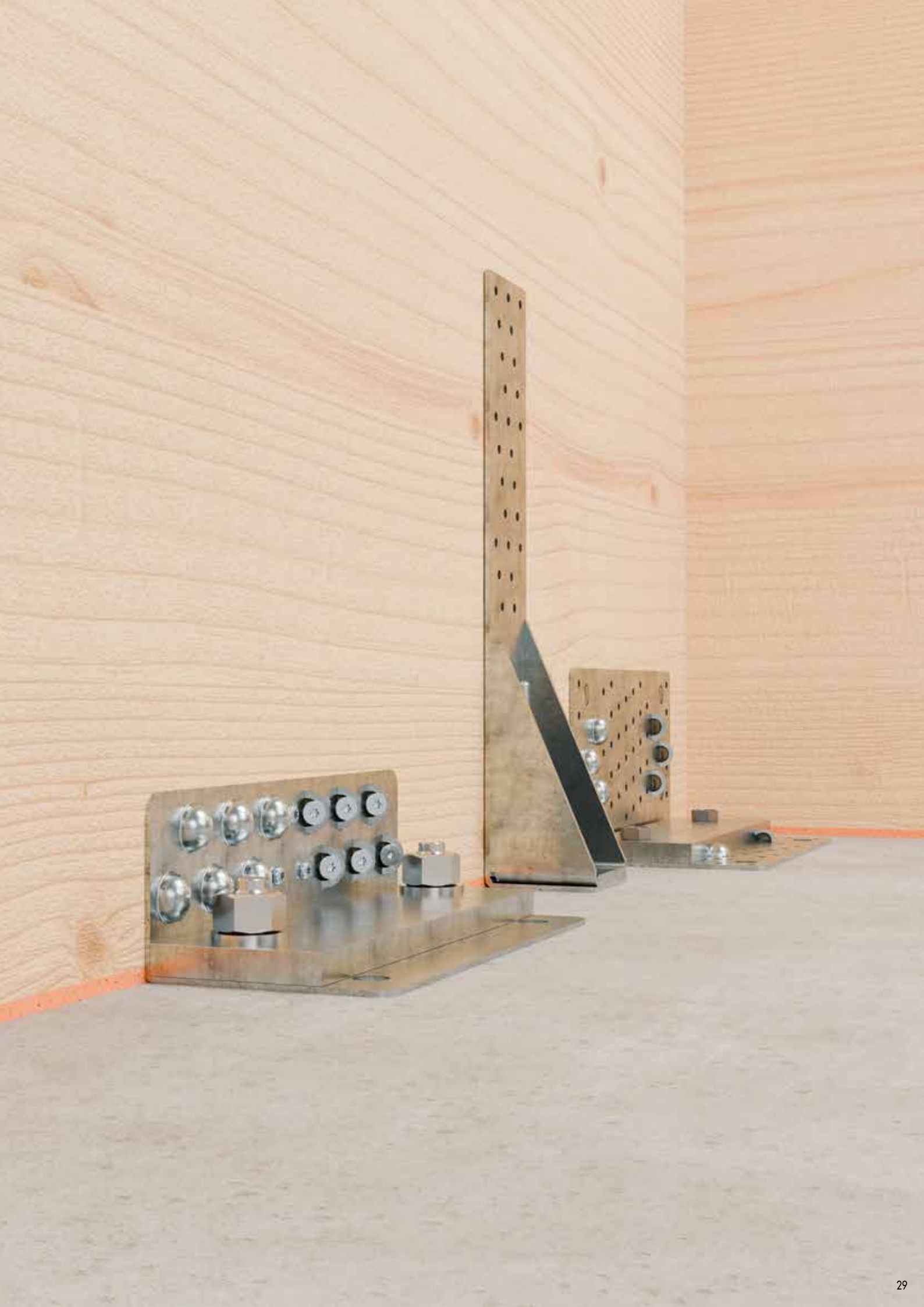

# WALL AND FLOOR SYSTEMS

# 2





## 2.1 ANGLES:

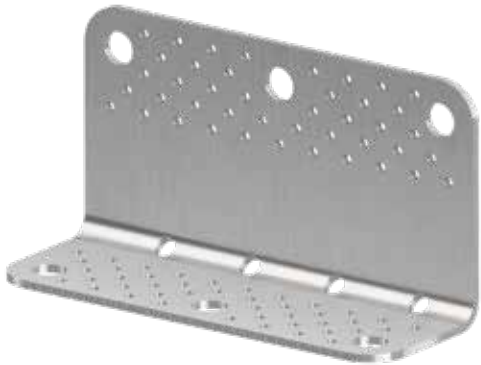

### 2.1.1 CLT SYSTEM ANGLES

The CLT system angle is ideally suited for use in CLT constructions to transmit forces in all directions like F1, F23, F45. Unlike the standard angles, the CLT system angle can be combined with our IdeeFix connector or metric bolts. This offers greater possibility to build complex connections using with our fully-threaded KonstruX screws.



Art. no.	Dimensions [mm]	Material	Material thickness [mm]	PU
954180	230 x 120	S250 galvanised	4	1

#### FASTENERS:

Type	Description	Illustration
Angle bracket screws (ABS)	Plate screw, Ø 5 mm	
KonstruX	Perfect hold in the corner holes	
Anchor nails	Ring shank nail, Ø 4 mm	

## APPLICATION IMAGE





## 2.1.2 CLT INSIDE CORNERS

The CLT inside corner system by Eurotec is a connector specially developed to withstand shear and tension forces when working with CLT wall panels. The connector can be joined to other interior corner systems to ease the application. This reinforcement mitigates the additional usage of hold-downs at the corners of CLT walls. The CLT interior corner system can be combined with our IdeeFix connector or metric bolts.

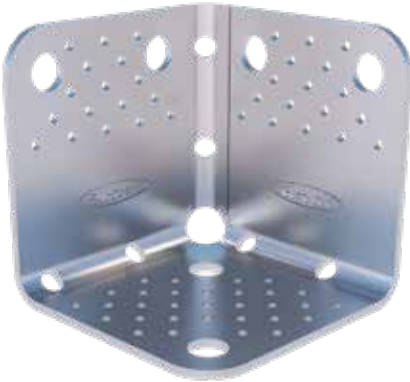

Art. no.	Dimensions [mm]	Material	Material thickness [mm]	PU
954188	120 x 120 x 120	S250 galvanized	4	1

### FASTENERS:

Type	Description	Illustration
Angle bracket screws (ABS)	Plate screw, Ø 5 mm	
KonstruX	Perfect hold in the angled holes	
Anchor nails	Ring shank nail, Ø 4 mm	
IdeeFix	Hidden wood connector	
Metric bolt	Hexagon screw anchors	

### APPLICATION IMAGE

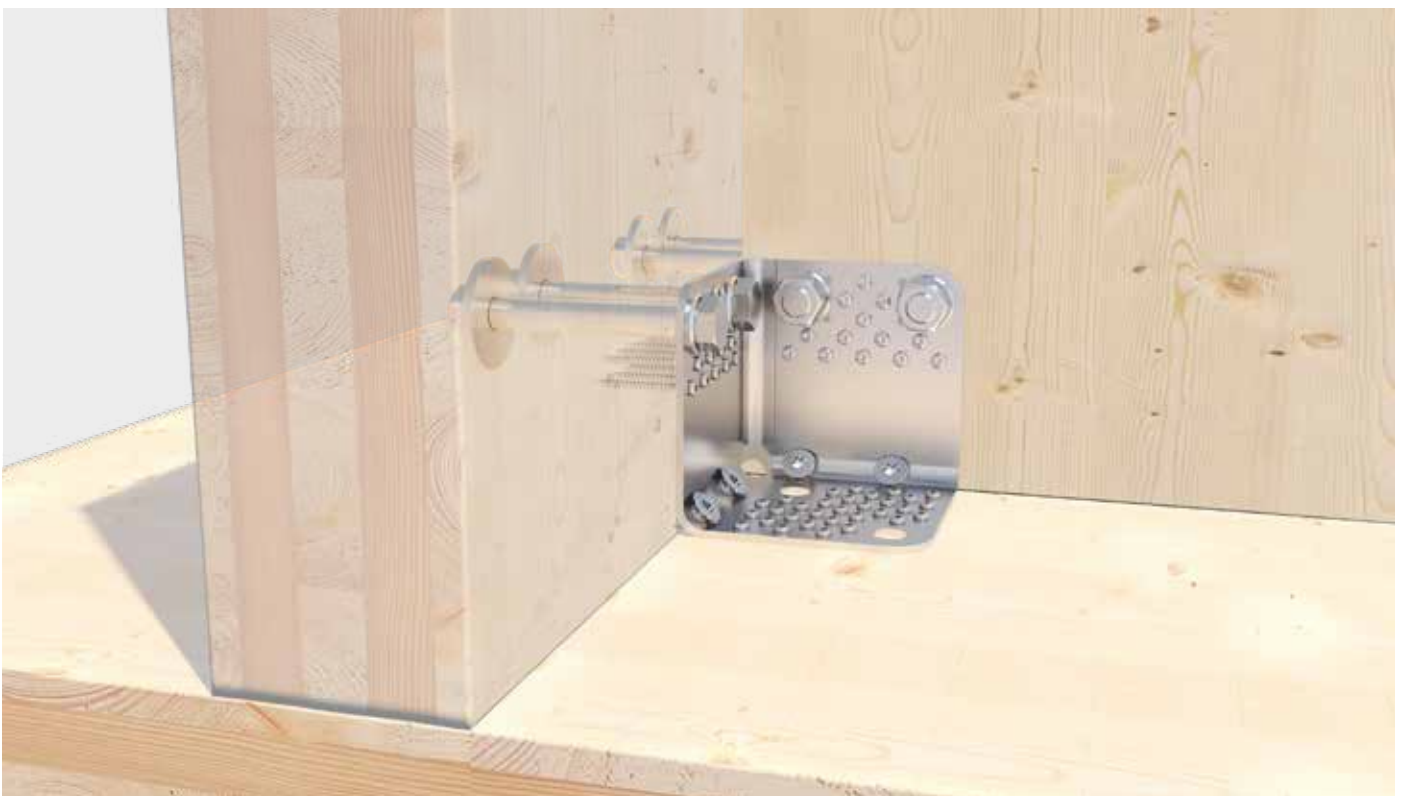



## 2.1.3 SHEARING ANGLE

In CLT wall-to-floor joints, the system delivers impressive shear capacities of up to 47.9 kN, combining strength with superior acoustic comfort. For wood-to-wood connections involving shear angles, the SonoTec Angular Decoupler can be used to improve performance. It is manufactured from SK04, a material consisting of cork and natural rubber, and serves primarily to dampen sound vibrations.



Art. no.	Dimensions [mm]	Material	Material thickness [mm]	PU
954112	230 x 120	S250 galvanised	3	1

### FASTENERS:

Type	Description	Illustration
Angle bracket screws (ABS)	Plate screw, Ø 5 mm	
Anchor nails	Ring shank nail, Ø 4 mm	
Panelwistec	Wood construction screw with a special screw tip and milling ribs above the thread.	

## APPLICATION IMAGE

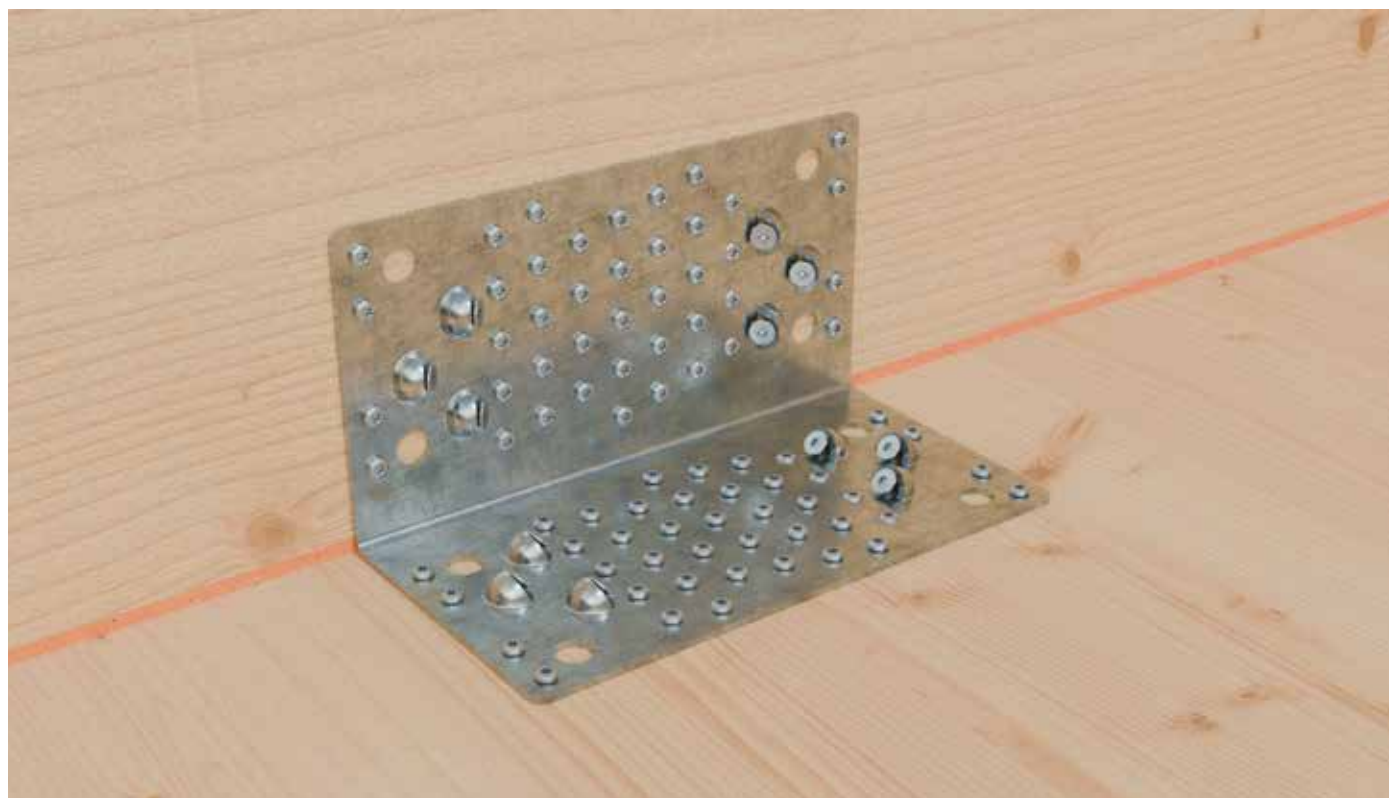



## 2.1.4 HH FLAT SHEARING ANGLE

The HH flat shearing angle (wood-wood) is a bracket connector for resisting shear and tension forces that is specifically developed for modern CLT construction. Its low height means that it is ideally suited to use in wood frame construction. It could be used in combination with SonoTec. In the case of CLT wall-to-floor joints, the shear capacity could reach to 40 kN with the tension capacity of 30 kN.



Art. no.	Dimensions [mm]	Material	Material thickness [mm]	PU
954088	230 x 70	S250 galvanised	3	1

### FASTENERS:

Type	Description	Illustration
Angle bracket screws (ABS)	Plate screw, Ø 5 mm	
Paneltwistec	Wood construction screw ø5 x 120 mm	
KonstruX	Perfect hold in the angled holes	

### APPLICATION IMAGE





## 2.1.5 ANGLE-BRACKET WITH A RIB

The Angle bracket with a rib comes in four different dimensions. The connector 's stability, provided by the reinforcement bead, allows connections with shear capacities.



Art. no.	Dimensions [mm]	Material	Material thickness [mm]	PU
904725	70 x 70	S 250 GD + Z 275	2	100
904726	90 x 90	S 250 GD + Z 275	2,5	100
904727	100 x 100	S 250 GD + Z 275	3	50
904729	110 x 170	S 250 GD + Z 275	3	25

### FASTENERS:

Type	Description	Illustration
Angle bracket screws (ABS)	Plate screw, Ø 5 mm	
Anchor nails	Ring shank nail, Ø 4 mm	

### APPLICATION IMAGE

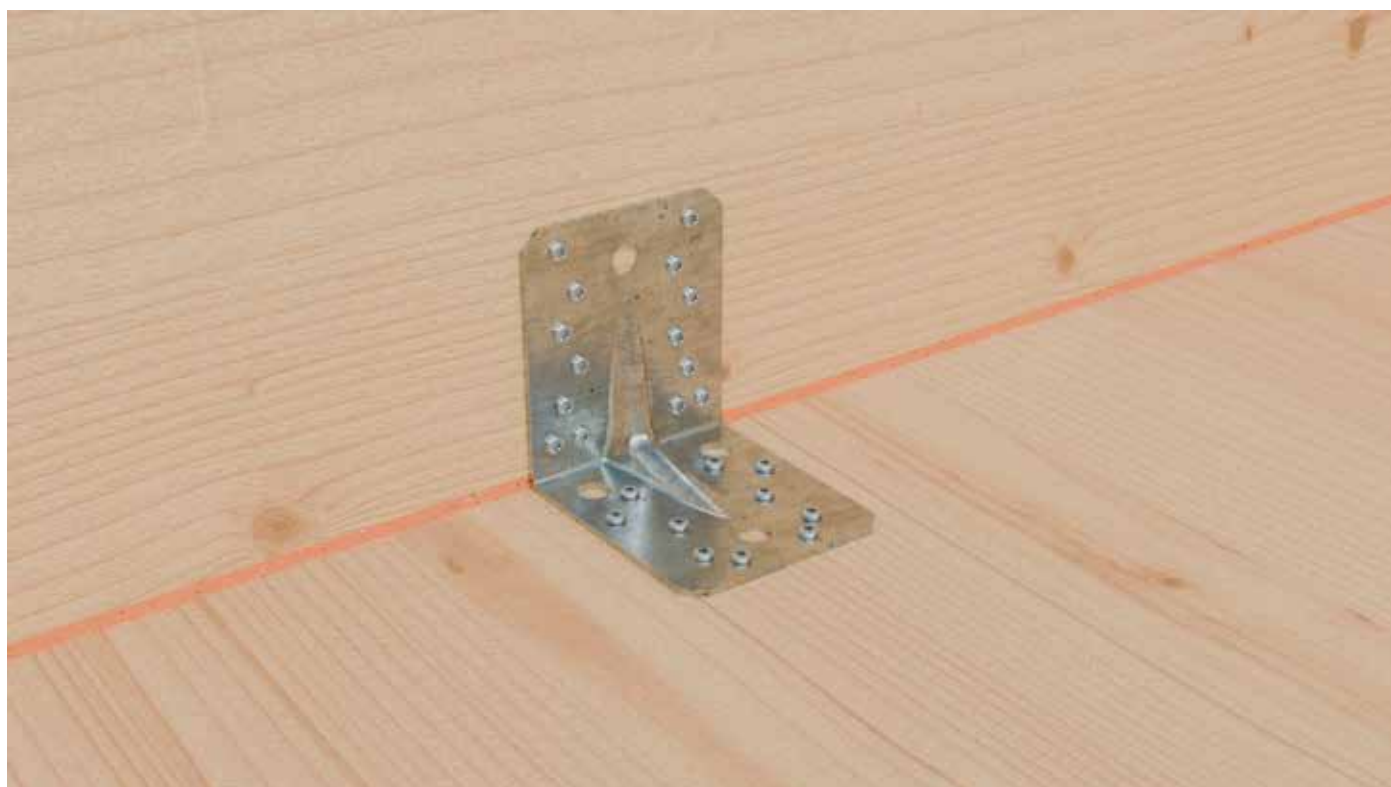



## 2.1.6 CLT BRACKET

CLT brackets offer both wood-concrete and wood-wood connectors for resisting shear and uplift forces that are specifically developed for CLT structures. Moreover, it can be used in timber frame construction.



Art. no.	Dimensions [mm]	Material	Material thickness [mm]	PU
954236	110 x 105 x 6	S250 galvanised	2,5	1
954233	110 x 170 x 115	S250 galvanised	2,5	1
954235	150 x 70 x 50	S250 galvanised	2,5	1
854234	150 x 105 x 60	S250 galvanised	2,5	1

### FASTENERS:

Type	Description	Illustration
Angle bracket screws (ABS)	Plate screw, Ø 5 mm	
KonstruX	Fully threaded screw, Ø 8 mm	
Anchor nails	Ring shank nail, Ø 4 mm	

### APPLICATION IMAGE

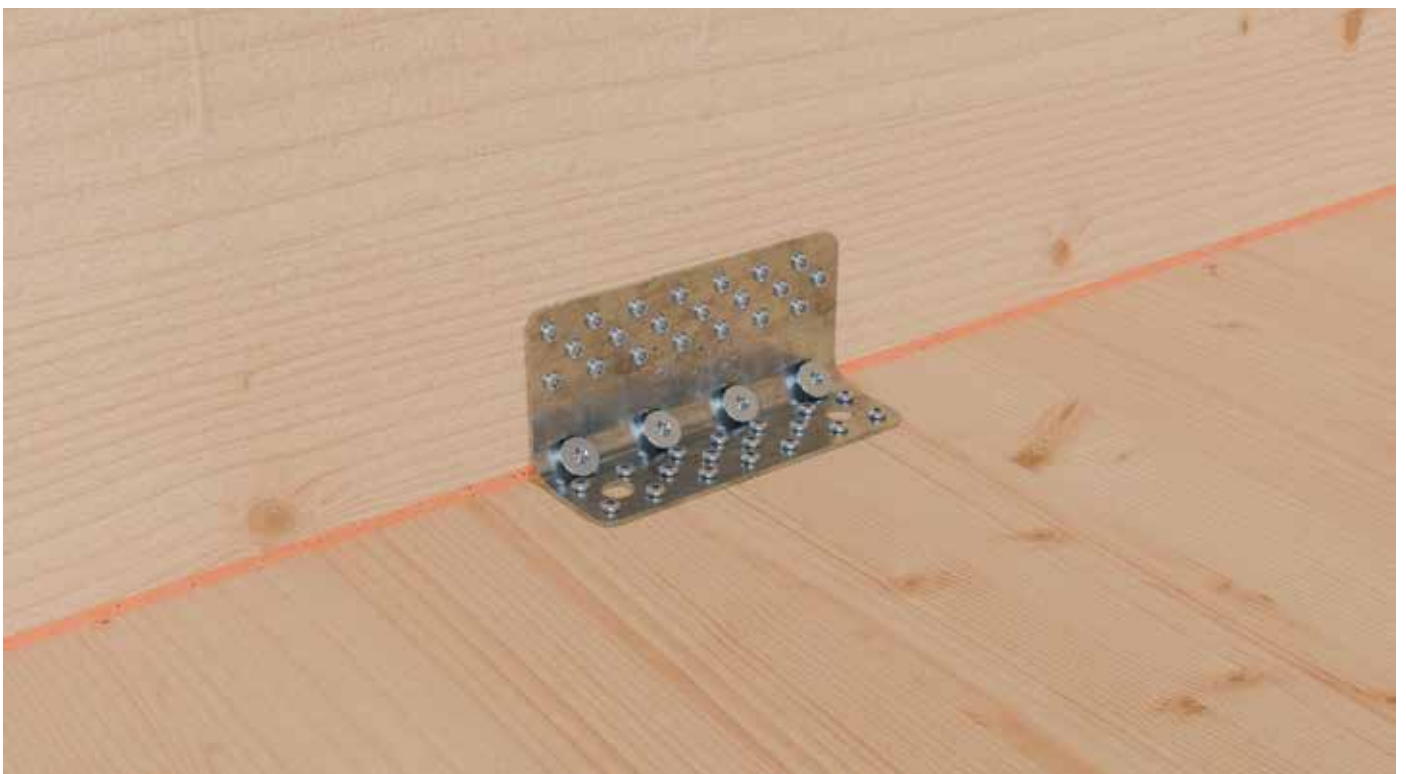

## 2.2 PLATES:

### 2.2.1 TENSION STRAPS HH 60, HH 70 AND HIGHLOAD

The tension straps are used to resist. Due to the special holes for anchoring in wood at a 45° and 90° angles, installation is not only very quick; it is also very efficient thanks to maximum utilization of the screw tensile capacity. The tension straps are used in timber frame and CLT construction.

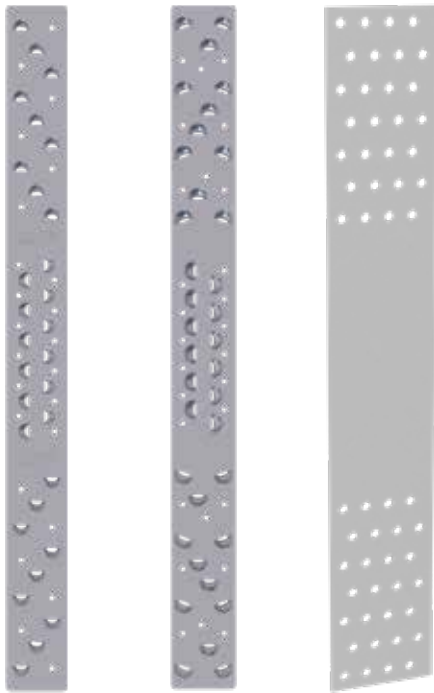



Tension strap  
HH60

Tension strap  
HH70

Tension strap  
HighLoad

Art. no.	Dimensions [mm]	Material	Material thickness [mm]	PU
954096	680 x 60	S250	3	1
954098	740 x 70	S250	3	1
954190	634 x 90	S355	3	1
954191	762 x 115	S355	4	1
954192	826 x 140	S355	5	1

#### FASTENERS:

Type	Description	Illustration
Angle bracket screws (ABS)	Plate screw, Ø 5 mm	
Panelwistec	Wood construction screw with a special screw tip and milling ribs above the thread	

### APPLICATION IMAGE

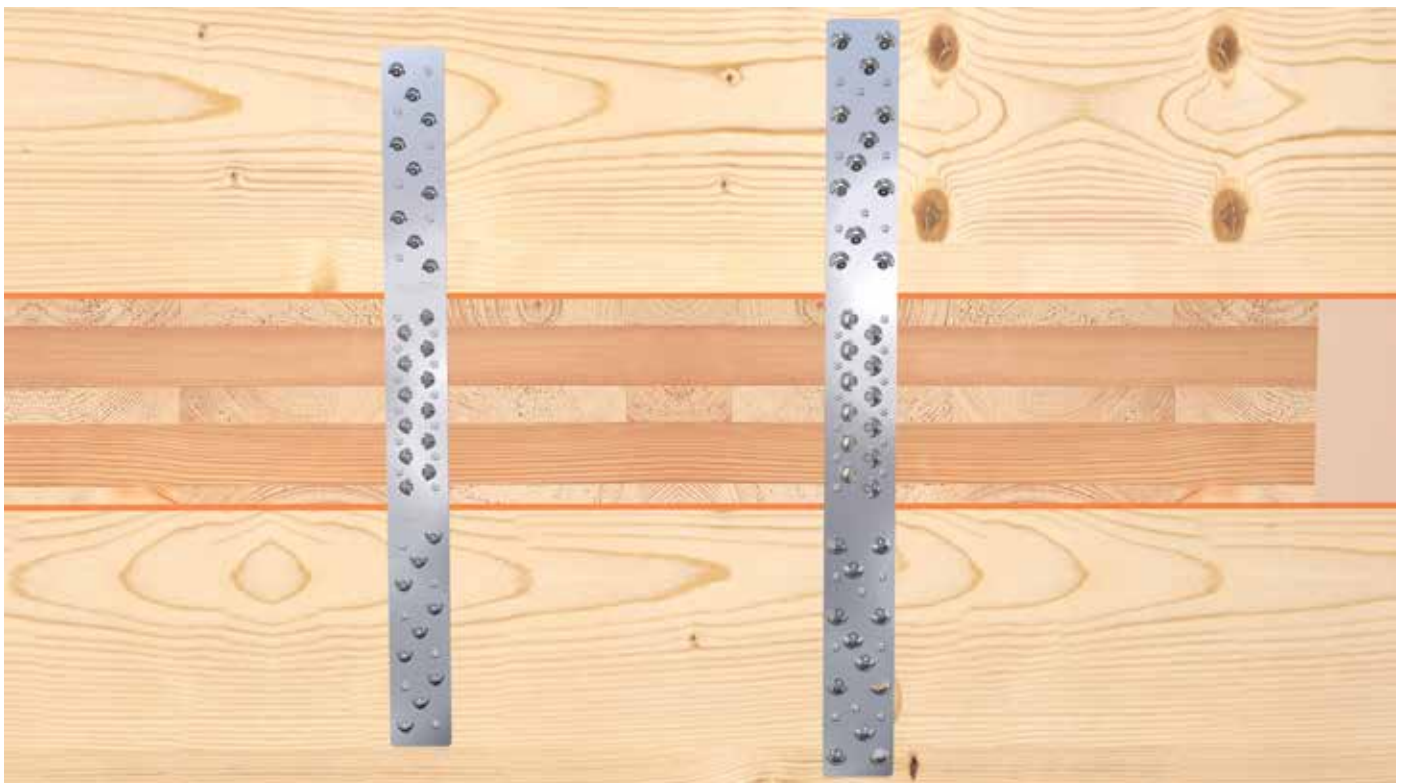



## 2.2.2 SHEARING PLATE

The shearing plate is used for resisting shear and tension forces. It has an optimized hole pattern for use with both wood and concrete connections in CLT construction. Maximum shear and tension capacities in wood-wood application of 47,9 kN and 116 kN, respectively.



Art. no.	Dimensions [mm]	Material	Material thickness [mm]	PU
954113	230 x 240	S250 galvanized	3	1

### FASTENERS:

Type	Description	Illustration
Panelwistec	Partially threaded screw, Ø 5 mm x 120 mm	
Anchor nails	Ring shank nail, Ø 4 mm	
Angle-bracket screw	Plate screw, Ø 5 mm	

### APPLICATION IMAGE



## 2.2.3 PERFORATED PANELS AND PERFORATED PANEL STRIP

The perforated panel strips are suitable for wood-wood joints. They are particularly simple, quick-to-assemble fastening elements for narrow wooden parts or structures such as strut connections or truss connections. The perforated panel strips are available in 2.0- and 2.5-mm thicknesses.



Art. no.	Dimensions [mm]	Material	PU
904649	40 x 1200 x 2,0	Steel plate DX 51D + Z 275	20
904600	60 x 1200 x 2,0	Steel plate DX 51D + Z 275	20
904601	80 x 1200 x 2,0	Steel plate DX 51D + Z 275	20
904602	100 x 1200 x 2,0	Steel plate DX 51D + Z 275	10
904603	120 x 1200 x 2,0	Steel plate DX 51D + Z 275	10
904604	140 x 1200 x 2,0	Steel plate DX 51D + Z 275	10
904020	160 x 1200 x 2,0	Steel plate DX 51D + Z 275	10
904021	180 x 1200 x 2,0	Steel plate DX 51D + Z 275	10
904022	200 x 1200 x 2,0	Steel plate DX 51D + Z 275	5
904023	220 x 1200 x 2,0	Steel plate DX 51D + Z 275	5
904024	240 x 1200 x 2,0	Steel plate DX 51D + Z 275	5
904025	260 x 1200 x 2,0	Steel plate DX 51D + Z 275	5
904026	280 x 1200 x 2,0	Steel plate DX 51D + Z 275	5
904027	300 x 1200 x 2,0	Steel plate DX 51D + Z 275	5
904028	400 x 1200 x 2,0	Steel plate DX 51D + Z 275	5
904029	40 x 1200 x 2,5	Steel plate DX 51D + Z 275	10
904030	60 x 1200 x 2,5	Steel plate DX 51D + Z 275	10
904031	80 x 1200 x 2,5	Steel plate DX 51D + Z 275	10
904032	100 x 1200 x 2,5	Steel plate DX 51D + Z 275	10
904033	120 x 1200 x 2,5	Steel plate DX 51D + Z 275	10
904034	140 x 1200 x 2,5	Steel plate DX 51D + Z 275	5
904035	160 x 1200 x 2,5	Steel plate DX 51D + Z 275	5
904036	180 x 1200 x 2,5	Steel plate DX 51D + Z 275	5
904037	200 x 1200 x 2,5	Steel plate DX 51D + Z 275	5
904038	220 x 1200 x 2,5	Steel plate DX 51D + Z 275	5
904039	240 x 1200 x 2,5	Steel plate DX 51D + Z 275	5
904040	260 x 1200 x 2,5	Steel plate DX 51D + Z 275	5
904041	280 x 1200 x 2,5	Steel plate DX 51D + Z 275	5
904042	300 x 1200 x 2,5	Steel plate DX 51D + Z 275	5
904043	400 x 1200 x 2,5	Steel plate DX 51D + Z 275	5

### APPLICATION IMAGE

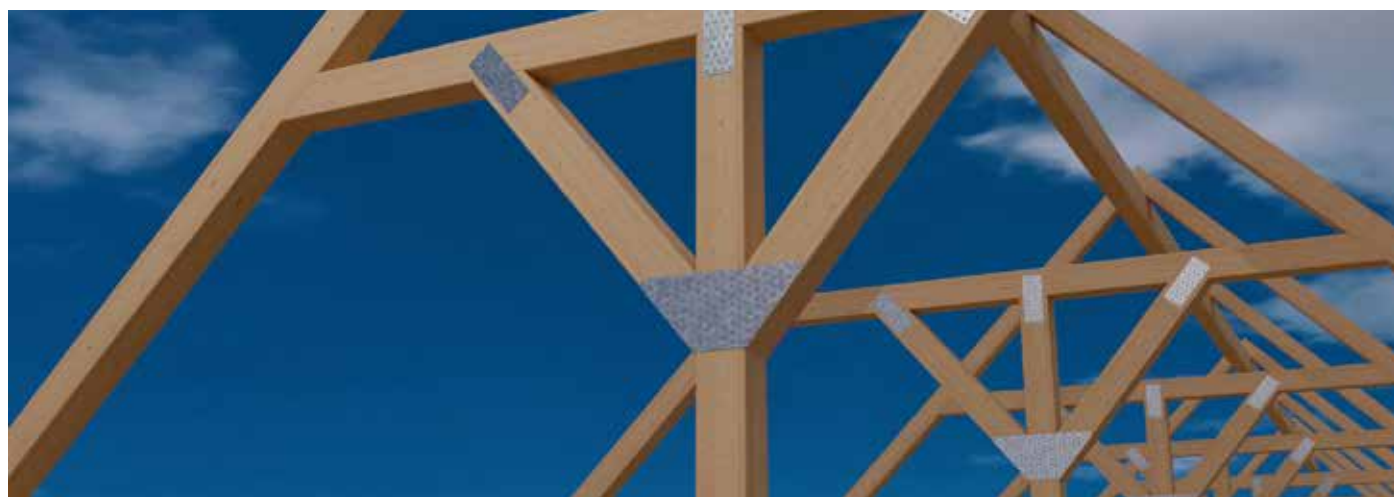



### 3.1 HOLD DOWNS:

#### 3.1.1 TENSION-RODS

The Tension rod 340/440/540/620 are moulded sheet steel parts especially for CLT construction for transfer of tensile forces. They enable quick and easy base point anchoring of wooden elements in wood, steel or concrete substrates.



Art. no.	Dimensions [mm]	Material	Material thickness [mm]	PU
954099	340 x 60 x 63 x 3	Galvanised S355 construction steel	3	1
954100	440 x 60 x 63 x 4	Galvanised S355 construction steel	3	1
954231	540 x 80 x 75 x 4	Galvanised S355 construction steel	3	1
954232	620 x 80 x 75 x 5	Galvanised S355 construction steel	3	1

#### FASTENERS:

Type	Description	Illustration
Angle bracket screws (ABS)	Plate screw, Ø 5 mm	
Threaded rod	For through-the-wall / slab mounting	
Anchor nails	Ring shank nail, Ø 4 mm	
Pressure plates	The tensile force can be increased in combination with the pressure plate	

#### APPLICATION IMAGE





## 3.1.2 SIMPLY TIE-BAR

The Simply tie bar allows quick and easy timber-timber, timber-concrete, timber-steel and timber-brickwork connections. It is especially sturdy and can withstand moderate tension loads. The Simply tie bar has nail holes on one side and screw holes (including a slot) in the other.



Art. no.	Dimensions [mm]	Material	Material thickness [mm]	PU
954056	95 x 88	S250 Galvanised	4	25
954057	135 x 88	S250 Galvanised	4	25
954058	285 x 88	S250 Galvanised	4	25

### FASTENERS:

Type	Description	Illustration
Angle bracket screws (ABS)	Plate screw, Ø 5 mm	
Anchor nails	Ring shank nail, Ø 4 mm	
Threaded rod	For through-the-wall mounting	

### APPLICATION IMAGE

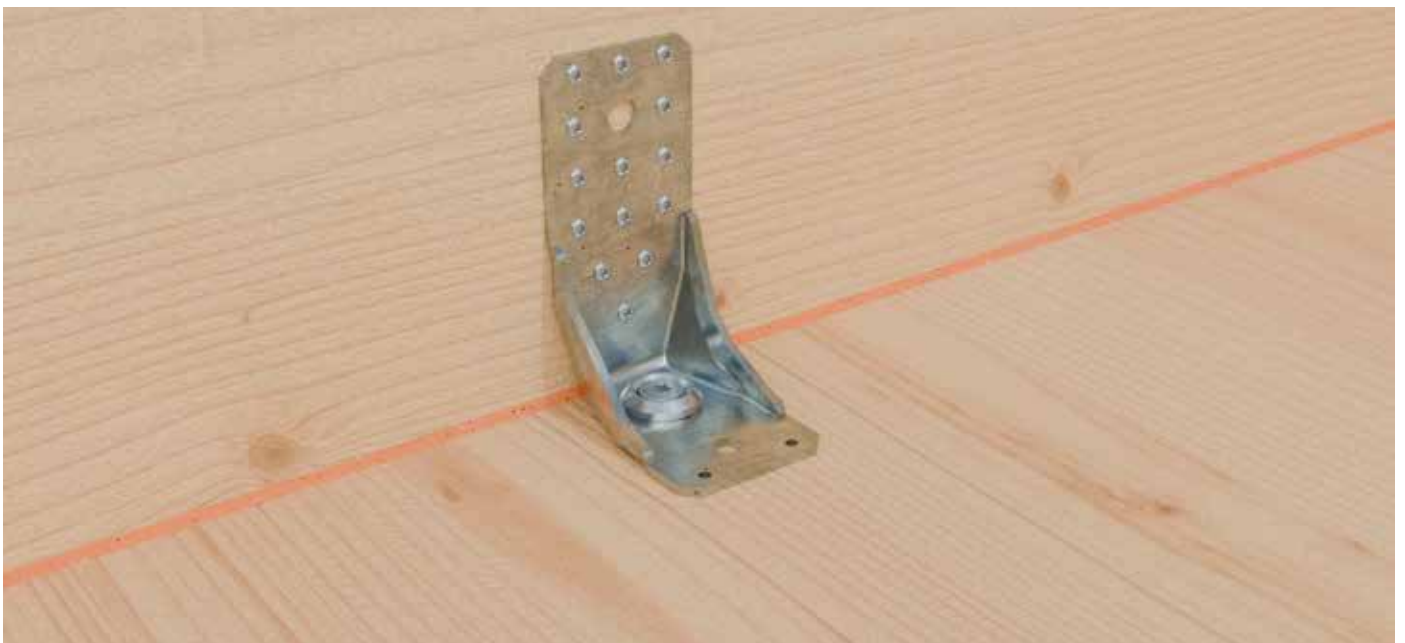

POSTS 3







## STRUCTUS

The Structus system enables seamless connection of timber columns through a ceiling, allowing the creation of a true point-supported CLT slab system for multi-storey or high-rise mass timber buildings. Its 30° screw insertion through the base and top plates ensures optimal force transfer in every direction, while the integrated steel core prevents lateral shear failure and enhances vertical load transmission between supports. By minimizing the need for primary and secondary beams, Structus not only accelerates construction but also delivers significant savings in material and cost.



Art. no.	Model	Bottom and top plates [mm]	Bottom tube [mm]	Steel bar [mm]	Material	PU
946260	Structus 1829	180 x 180 x 30	60 x 5 x 290	48 x 290	S355	1
946261	Structus 1837	180 x 180 x 30	60 x 5 x 370	48 x 370	S355	1
946262	Structus 2230	220 x 220 x 35	76 x 5 x 300	64 x 300	S355	1
946263	Structus 2238	220 x 220 x 35	76 x 5 x 380	64 x 380	S355	1
946264	Structus 2630	260 x 260 x 40	102 x 5 x 305	90 x 305	S355	1
946265	Structus 2638	260 x 260 x 40	102 x 5 x 385	90 x 385	S355	1

### FASTENERS:

Type	Description	Illustration
KonstruX	Perfect hold in wood at an angle and straight	
Bolt anchors Ø 12 mm	Torque-controlled expanding plug	

## STRUCTUS BASE



Art. no.	Model	Bottom plate [mm]	Top plate [mm]	Height [mm]	Material	PU
946350	Structus Base 1217	180 x 180	120 x 120	200	S275 galvanized	1
946351	Structus Base 1616	220 x 220	160 x 160	200	S275 galvanized	1
946352	Structus Base 1813	180 x 310	180 x 180	180	S275 galvanized	1
946353	Structus Base 2213	220 x 350	220 x 220	180	S275 galvanized	1
946354	Structus Base 2612	260 x 390	260 x 260	180	S275 galvanized	1

APPLICATION IMAGE

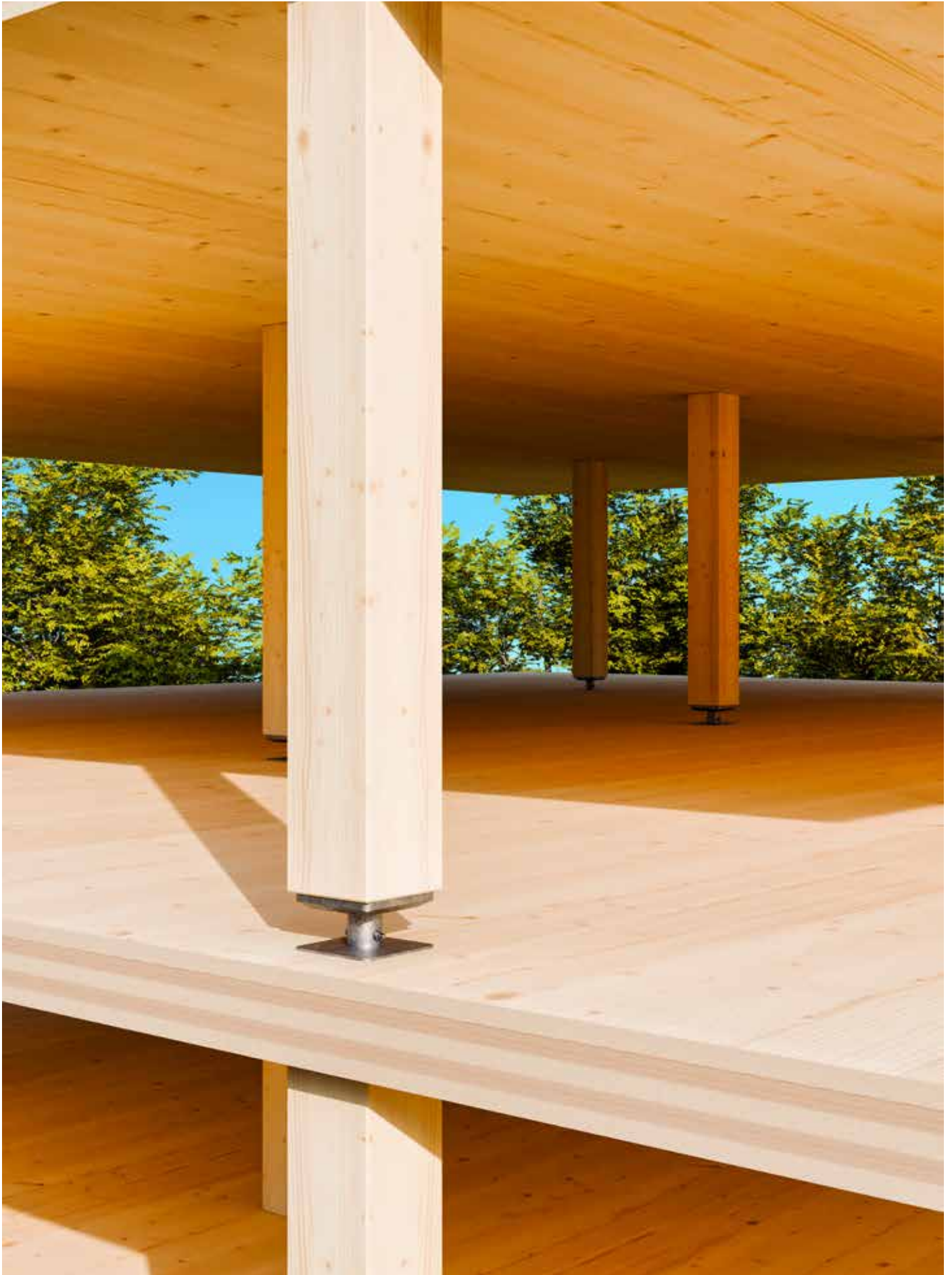

## PEDiX POST FEET

The PediX post foot is a post base for structural wood protection. It can be mounted directly to the end-grain wood of the post by means of 12 fully threaded screws. An EPDM joint between post foot and post ensures additional protection of the wood against penetrating moisture. Following assembly, the post foot is still height-adjustable up to 50, 100 or 150 mm, respectively (except post foot B500). Any production tolerances due the construction or the subsequent setting of the foundations can be compensated by means of the height adjustment. The post foot offers high compressive load capacities. The durability of the foot is ensured by means of hot dip galvanization in accordance with DIN EN ISO 12944-2 (C3).



Description	Art. no.	Height adjustment in assembled state	Min. cross section of post	Dimensions of base plate			Compressive load-bearing capacity	Tensile load-bearing capacity	Shear force load-bearing capacity <sup>1)</sup>	PU
				Length [mm]	Width [mm]	Height [mm]				
Post bases on concrete		[mm]	[mm]				$N_{c,d}$ [kN]	$N_{t,d}$ [kN]	$V_{R,d}$ [kN]	Piece
PediX 140+50	904681	140 – 190	100 x 100	160	100	8	48,0	9,2	-	4
PediX 190+100	904682	190 – 290	100 x 100	160	100	8	30,9	9,2	-	4
PediX 300+150	904689	300 – 450	100 x 100	160	100	8	16,2	9,2	-	4
PediX 140+50 HV	904681-HV	140 – 190	100 x 100	160	100	8	48,0	9,2	3,5	4
PediX 190+100 HV	904682-HV	190 – 290	100 x 100	160	100	8	35,4	9,2	2,9	4
PediX 300+150 HV	904689-HV	300 – 450	100 x 100	160	100	8	34,5	8,6	2,3	4
Post bases in concrete		[mm]	[mm]				$N_{c,d}$ [kN]	$N_{t,d}$ [kN]		Piece
PediX B500	904683	-	100 x 100	-	-	-	49,0	24	4,6	4
PediX B500+50	904686	50	100 x 100	-	-	-	44,9	23	-	4

1) The shear force load-bearing capacity needs to be superimposed with the compressive and the tensile force according to ETA-13/0550, which can lead to lower load-bearing capacities. Please note: The stated values are planning aids. They are subject to typographical and printing errors. Final connection design must be confirmed by competent structural engineers.

APPLICATION IMAGE



BEAMS

4

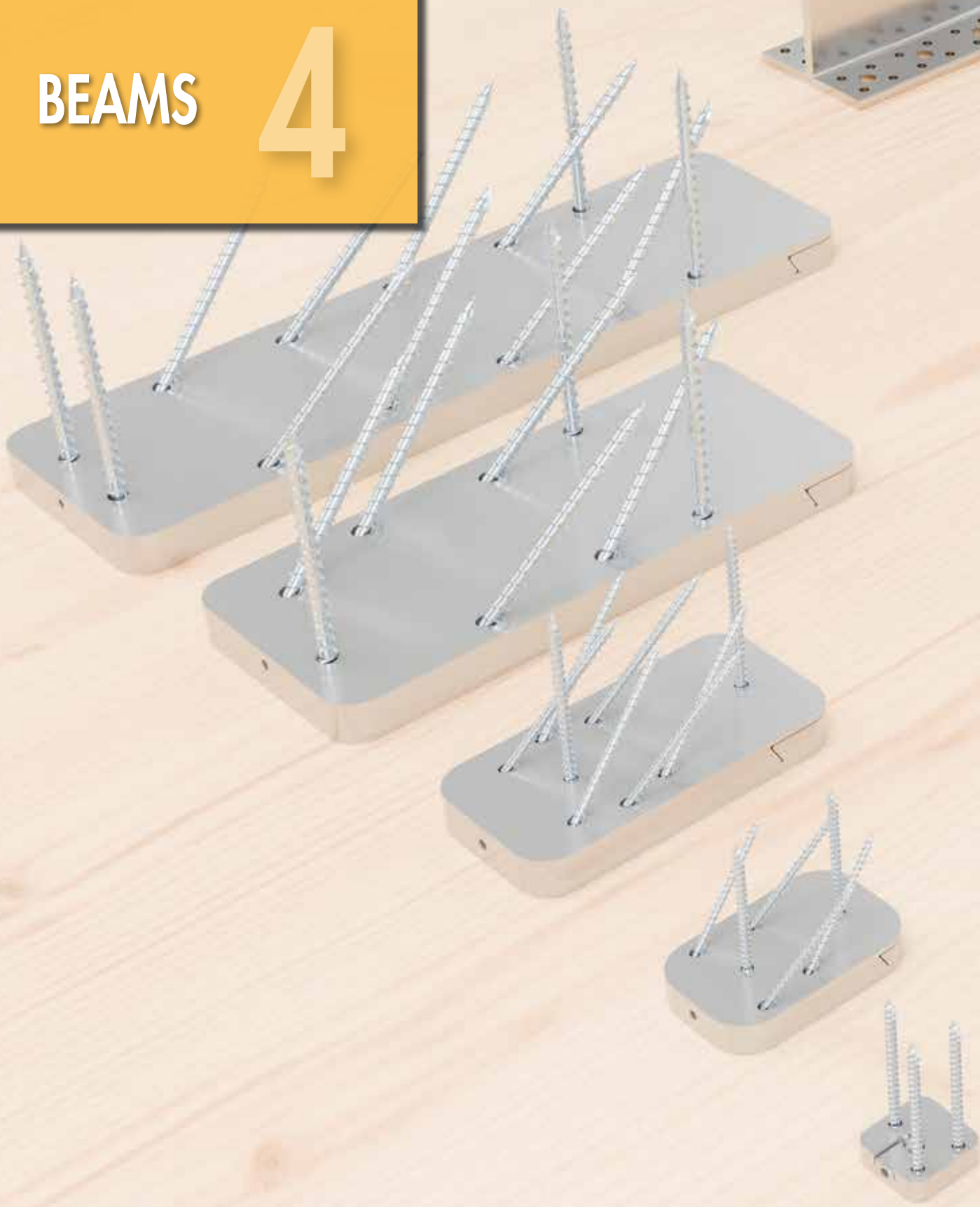



## MAGNUS HOOK CONNECTORS

The Magnus hook connector is used to create node joints in mass timber construction. This joint is impressive above all because it can be completely prefabricated, which in turn minimizes assembly time on the construction site. The connector consists of two different components, as well as wood construction screws and locking screws. The two separate parts of Magnus are attached to the respective structural members using the wood construction screws and then slotted into one another smoothly.



Art. no.	Product name	Dimensions [mm]	Material	PU
944874	Magnus XS	30 x 30 x 9	Aluminum	20*
944875	Magnus S	50 x 60 x 13	Aluminum	10
944876	Magnus S	50 x 80 x 13	Aluminum	10
944877	Magnus S	50 x 100 x 13	Aluminum	10
944878	Magnus M	70 x 120 x 17	Aluminum	10
944879	Magnus M	70 x 140 x 17	Aluminum	10
944880	Magnus M	70 x 160 x 17	Aluminum	10
944881	Magnus M	70 x 180 x 17	Aluminum	10
944882	Magnus L	110 x 220 x 19	Aluminum	10
944883	Magnus L	110 x 260 x 19	Aluminum	10
944884	Magnus L	110 x 300 x 19	Aluminum	10
944887	Magnus L	110 x 340 x 19	Aluminum	10
944888	Magnus L	110 x 380 x 19	Aluminum	10
944889	Magnus L	110 x 580 x 19	Aluminum	10

## APPLICATION IMAGES





## T-TEC SYSTEM: T-PROFILE AND EST RODS

T-profile is a beam-beam and beam-column hidden aluminum wood connector for use both Service Class 1 and 2. Suitable for perpendicular and angled joints between wood-wood, wood-concrete, and wood-steel. It can be combined with the EST rod dowel, which is screwed through both the wood beam and the T-profile as a part of a selfDrill tipping process.



Art. no.	Dimensions [mm]	Material	Thickness [mm]	PU
975652	115 x 2000 x 80	Aluminum	6	10

### FASTENERS:

Type	Description	Illustration
EST rod dowel	Self-Drill tipping smooth dowel, Ø 7,5 mm	
Angle bracket screws (ABS)	Plate screw, Ø 5 mm	
Bolt anchors	Torque-controlled expanding plug	
Rod dowels	Simple round rod in various sizes	
Anchor nails	Ring shank nail, Ø 4 mm	

### APPLICATION IMAGE

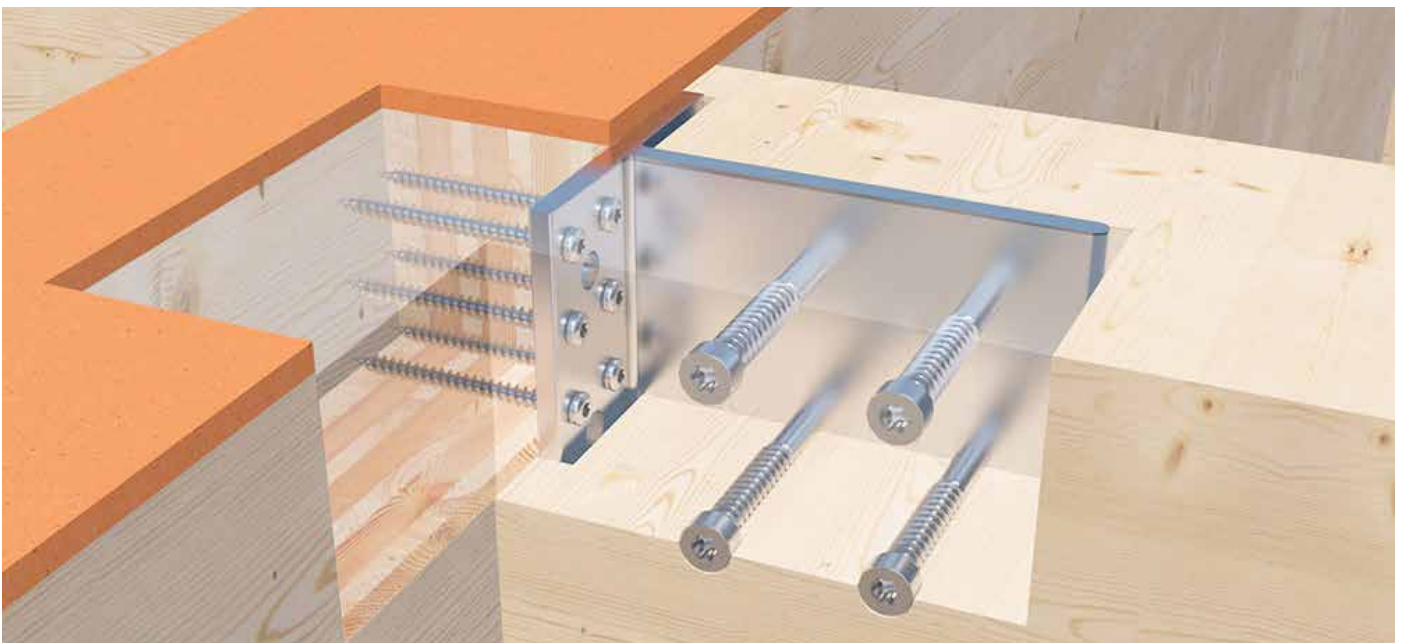

## CONNECTO

The Connecto hook connector is an innovative concealed timber-to-timber connector that provides high load-carrying capacity for beam to beam and beam to column connections in mass timber construction. The connectors are made of aluminium alloy and are suitable for Service Class 1 and 2 conditions. This joint provides a quick assembly solution using a single type of KonstruX screw. It can also be easily assembled and disassembled since two separate aluminium parts of Connecto are attached to the respective structural timber members by hanging into a slot combined with a locking screw.



Art. no.	Designation	Dimension [mm]	PU
944010	Connecto H135 B50	135 x 50	10
944011	Connecto H175 B50	175 x 50	10
944012	Connecto H175 B75	175 x 75	10
944013	Connecto H215 B75	215 x 75	10
944015	Connecto H240 B75	240 x 75	10
944017	Connecto H240 B125	240 x 125	10
944019	Connecto H265 B100	265 x 100	10
944022	Connecto H290 B100	290 x 100	10

### ADVANTAGES AND SPECIFICATIONS

- Easy installation
- High degree of prefabrication
- High load capacity
- Concealed connections

### APPLICATION IMAGE



# INSTALLATION EXAMPLE

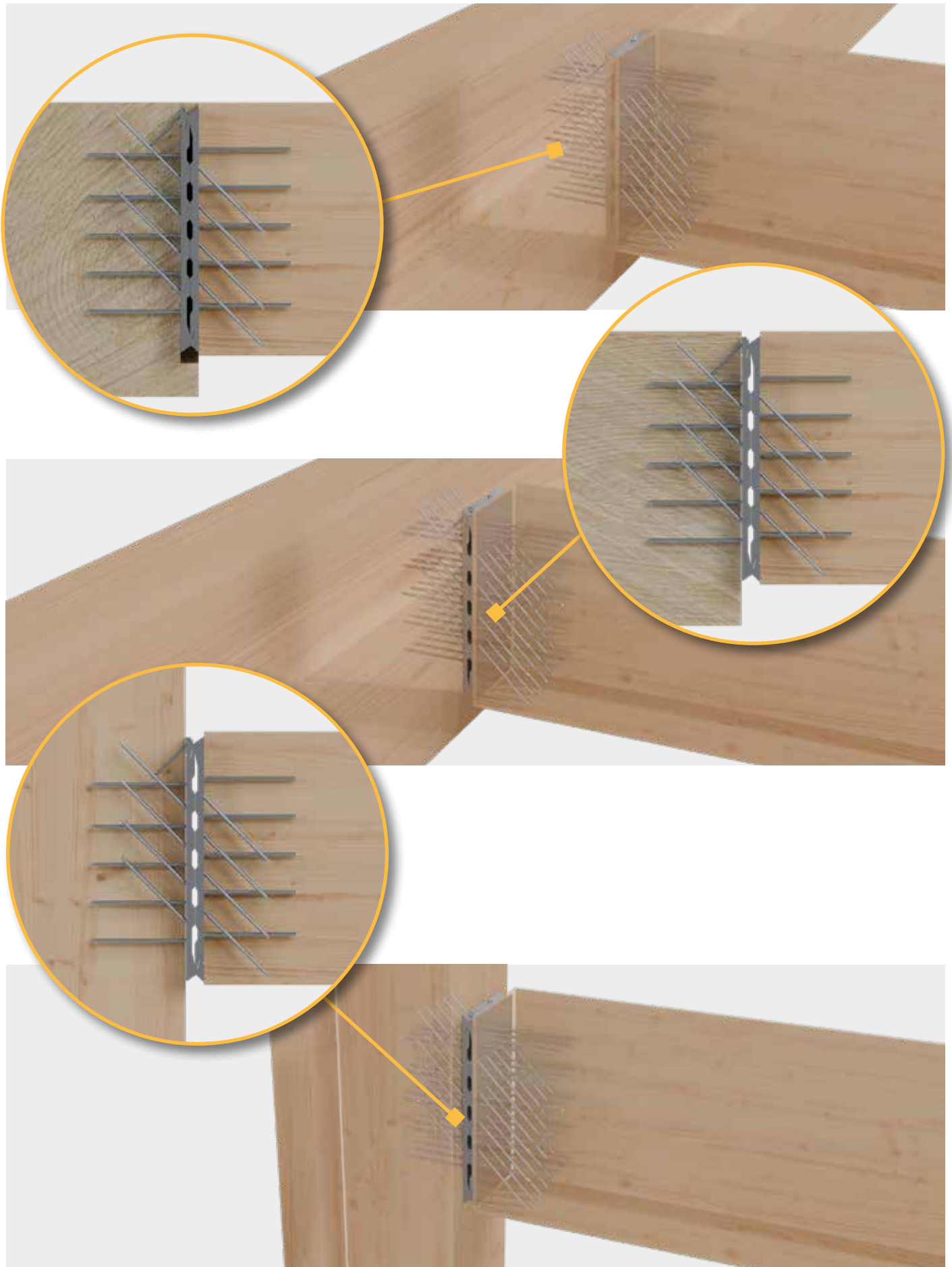

## IDEEFIX

The IdeeFix wood connector is used to create hidden wood connections for single- or multiple-row serial connections in wood-wood connections. It ensures high load-bearing capacity for tensile and shear forces, designed for universal use and it is quick and easy to install. The screws are included in the scope of delivery.



Art. no.	Designation	Dimension Diameter [mm]	PU
945390	IdeeFix 30	30	50
944890	IdeeFix 40	40	50
944896	IdeeFix 50	50	50

### ADVANTAGES AND SPECIFICATIONS

- High load-bearing capacity for tensile and transverse loads
- Adjustable tension/detachable
- Universal application
- Low wood-weakening effect
- For single- or multi-row series connections
- High pull-out resistance
- Strong connection
- Maximisation of the load-bearing capacity
- Time and cost-saving alternative
- Concealed connections
- No pre-Drill tipping required for screwed according to approval/ ETA (recommended for screw lengths > 245 mm)

i

### NOTE

Only for use in timber structures in service class 1 and 2 (protected from direct weathering).

### APPLICATION IMAGE

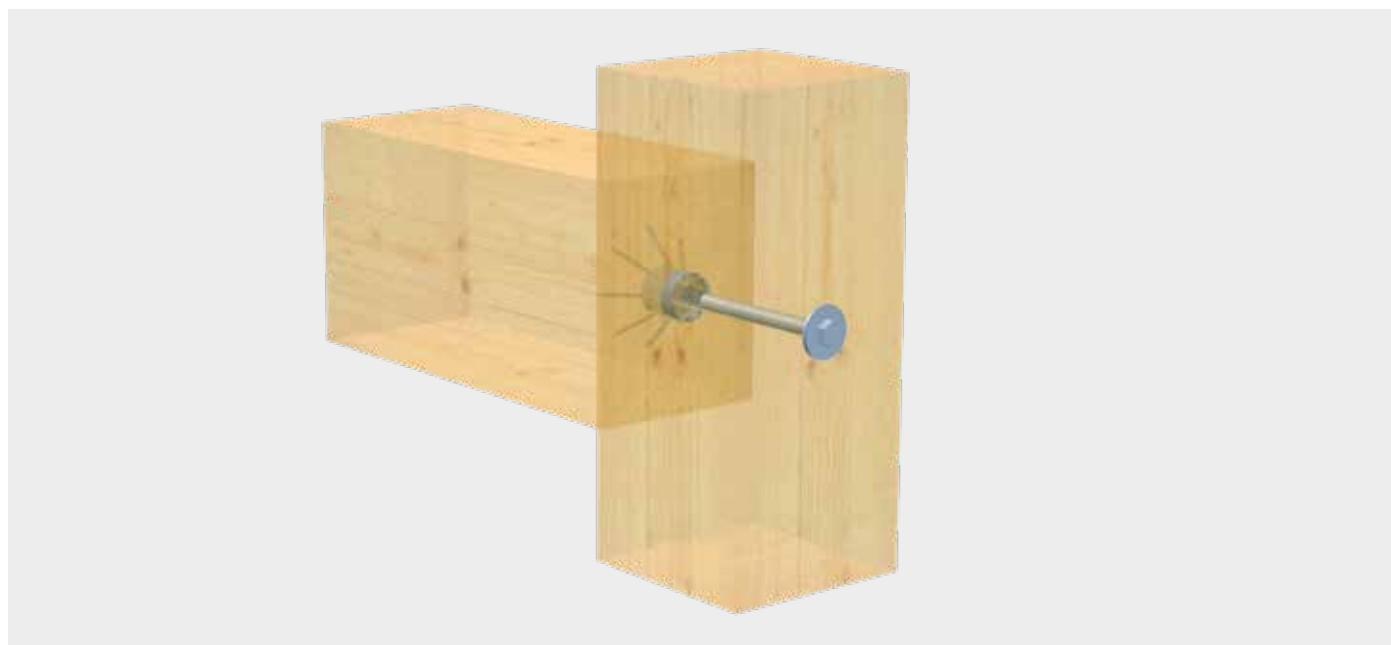

## JOIST HANGERS

Eurotec joist hangers are used to affix main girder and secondary girder connections. They can be used for concrete or timber and installed in KVH, BSH and CLT. There are two types, joist hangers with outer flange & with inner flange.







Art. no.	Dimensions [mm]	Material	Thickness [mm]	PU
904629	40 x 110	S 250 GD + Z 275	2	50
904642	45 x 108	S 250 GD + Z 275	2	50
904630	70 x 125	S 250 GD + Z 275	2	50
904631	80 x 120	S 250 GD + Z 275	2	50
904632	90 x 145	S 250 GD + Z 275	2	50
904633	100 x 140	S 250 GD + Z 275	2	50
904634	120 x 160	S 250 GD + Z 275	2	50
904635	140 x 180	S 250 GD + Z 275	2	50



Art. no.	Dimensions [mm]	Material	Thickness [mm]	PU
904628	40 x 110	S 250 GD + Z 275	2	50
904636	70 x 125	S 250 GD + Z 275	2	50
904637	80 x 120	S 250 GD + Z 275	2	50
904638	90 x 145	S 250 GD + Z 275	2	50
904639	100 x 140	S 250 GD + Z 275	2	50
904640	120 x 160	S 250 GD + Z 275	2	50
904641	140 x 180	S 250 GD + Z 275	2	50

### FASTENERS:

Type	Description	Illustration
Angle bracket screws (ABS)	Plate screw, Ø 5 mm	
Bolt anchors Ø 12 mm	Torque-controlled expanding plug	
Anchor nails	Ring shank nail, Ø 4 mm	
Threaded rod	With hex nut and washer	

### APPLICATION IMAGES



# ECKTEC

The EckTec connector can replace the conventional brace for single-storey wood frames buildings. This **allows a better look** without disruptive braces, especially at low installation heights.

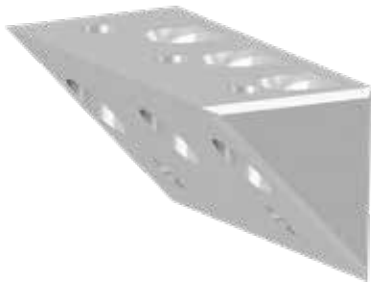

Art. no.	Dimensions [mm] <sup>a)</sup>	Material	PU*
975664	50 x 50 x 100	Aluminium	1

a) Width x Height x Depth  
\*Delivery incl. screws

### ADVANTAGES

- Supports load absorption with horizontal forces
- Pre-assembly at the factory optional
- Many different areas of use

### INSTRUCTIONS FOR USE

The EckTec connector is fixed with two 4 x 40 Paneltwistecs. The first KonstruX ST 8 x 155 fully-threaded screws are then set at 25° in the posts. After mounting the cross beam, the other 8 x 95 KonstruX ST fully threaded screws can be set at 90°. Min. cross-section of beam: 120 x 120 mm.



Load capacities EckTec 100 Timber - C24, ρ <sub>k</sub> = 350 kg/m <sup>3</sup> ; k <sub>mod</sub> =1,0	M <sub>1,Rd</sub> [kNm]	F <sub>1,Rd</sub> [kN]
Moment	1,39	-
Moment and Pulling force (combined)	0,96	8,4



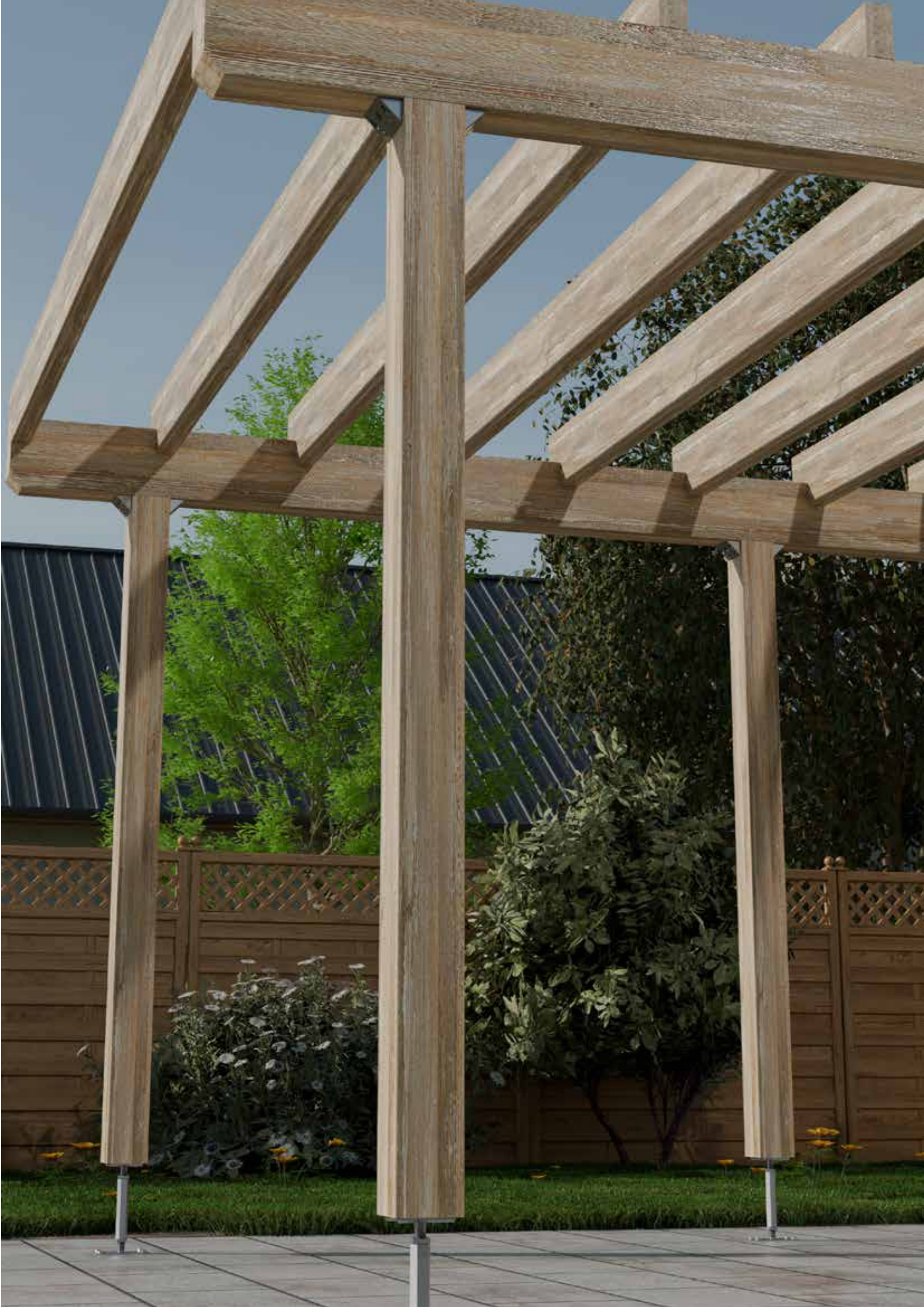

**MASS TIMBER  
SCREWS**

**5**

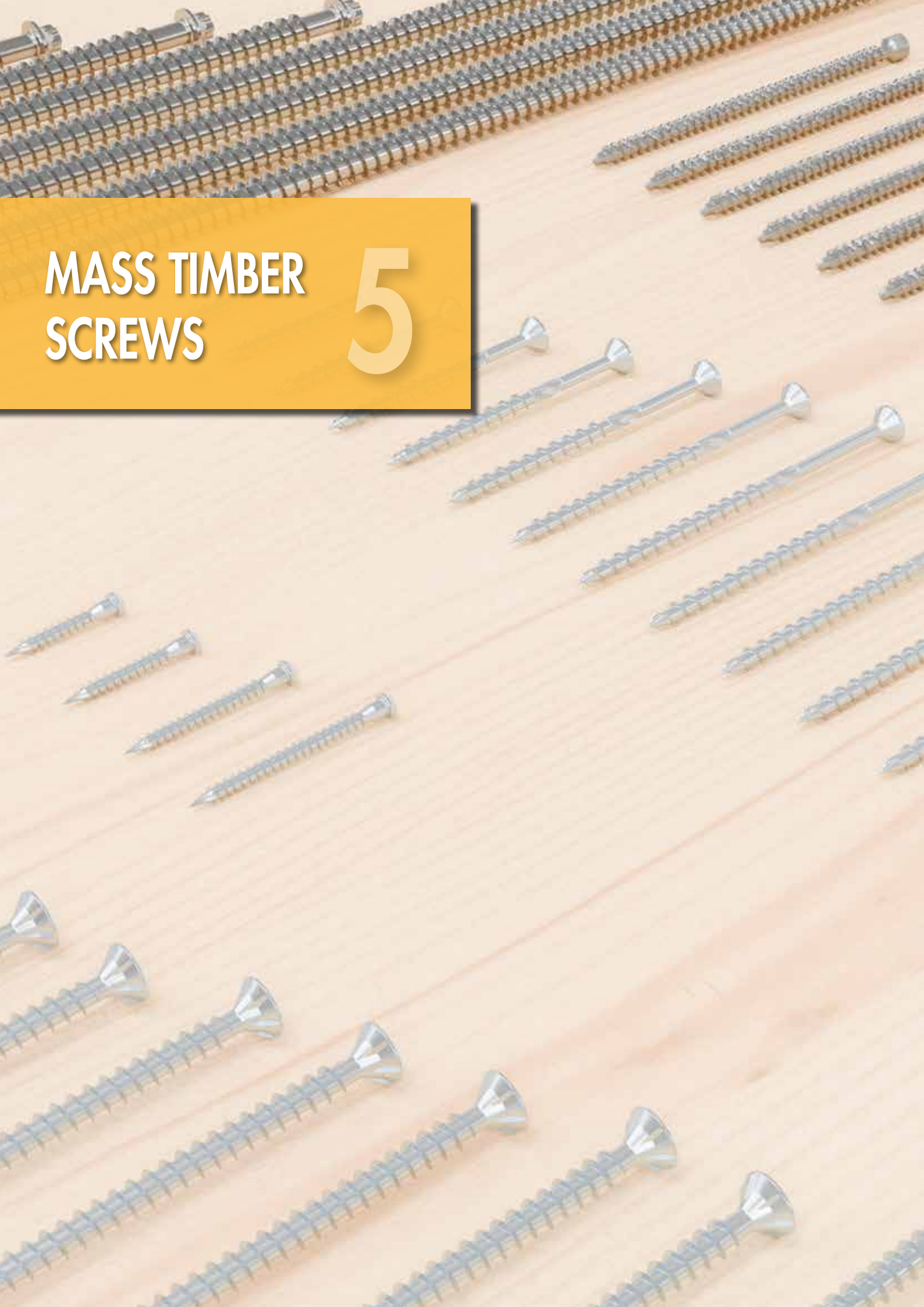



# KONSTRUX FULLY THREADED SCREW

The high-performance solution for new construction and refurbishment



KonstruX fully threaded screws maximize connection load-bearing capacity by providing high thread extraction resistance in both components, whereas partially threaded screws are limited by the much lower head pull-through resistance in the attachment part. As a result, KonstruX fully threaded screws offer a cost-effective alternative to traditional carpentry joints as well as timber connectors such as joist hangers.

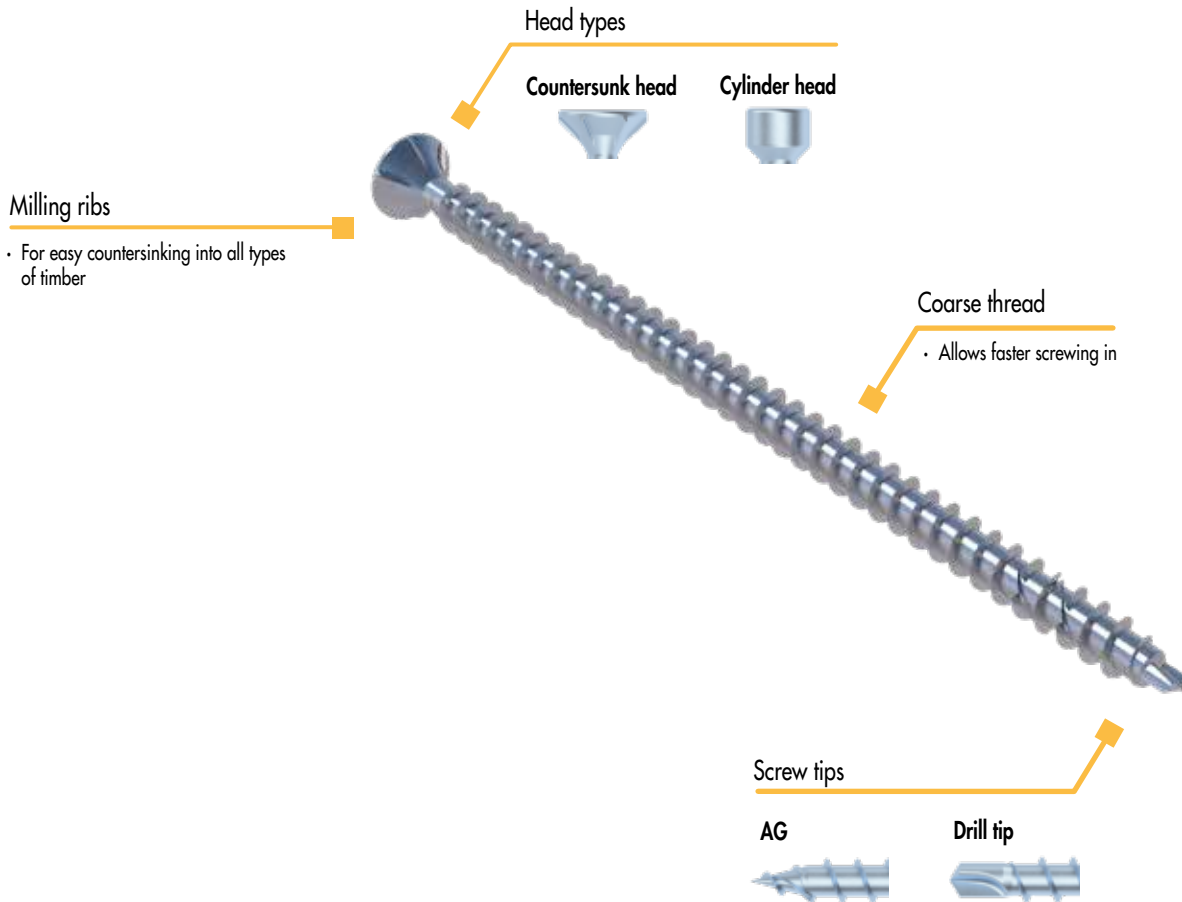

KonstruX Carbon Steel							
Geometric properties					Mechanical properties		
Nominal Ø [mm]	Root Ø <sub>i</sub> [mm]	Head <sup>a)</sup> Ø <sub>h</sub> [mm]	Head depth <sup>a)</sup> hh [mm]	Tip type	f <sub>rens,k</sub> [kN]	f <sub>ax,k</sub> [MPa]	M <sub>y,k</sub> [Nm]
5,2	3,6	9,8 / 6,4	4,8 / 5,0	Drill tip	13,0	15,5	10,0
5,9	3,6	11,7 / 8,0	5,7 / 5,5	Drill tip	17,0	15,5	15,0
6,5	4,5	12,0 / 8,0	5,7 / 5,5	Drill tip	17,0	15,5	15,0
8	5,2	14,5 / 10	7,4 / 6,5	Drill tip	25,0	12,5	25,0
10	5,9	17,8 / 13	8,7 / 6,5	Drill tip	33,0	11,5	40,0
11,3	8,0	18,0	7,0	AG	50,0	10,8	70,0

<sup>a)</sup> Countersunk head / Cylinder head.  
Ø 11,3 mm is only available as a countersunk head.

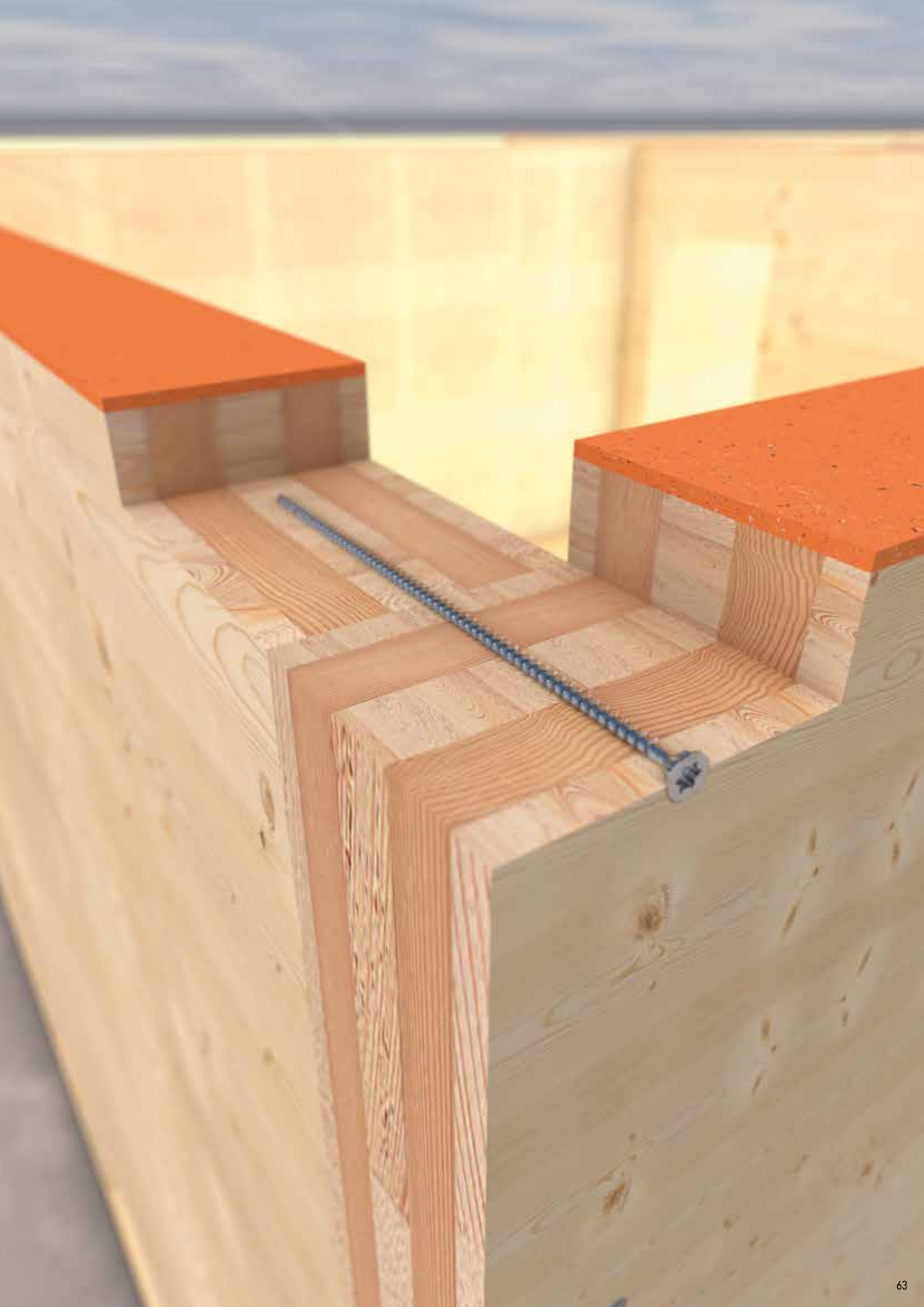

## MINIMUM DISTANCES FOR AXIAL LOADS

Drill tip							AG tip					
With and without preDrill tipped holes							PreDrill tipped			Not preDrill tipped		
Ø [mm]	Distance rules	5.2	5.9	6.5	8	10	Distance rules	11,3	13	Distance rules	11,3	13
a1	5·d	26	30	33	40	50	5 · d	57	65	5 · d	57	65
a2	5·d	26	30	33	40	50	5 · d	57	65	5 · d	57	65
a2,red	2,5·d	13	15	17	20	25	2,5 · d	29	33	2,5 · d	29	33
a1,c	5·d	26	30	33	40	50	5 · d	57	65	10 · d	113	130
a2,c	3·d	16	18	20	24	30	3 · d	34	39	4 · d	46	52
a1,x	1,5·d	8	9	10	12	15	1,5 · d	17	20	1,5 · d	17	20

### SCREWS ARRANGED CROSSWISE UNDER TENSILE LOAD

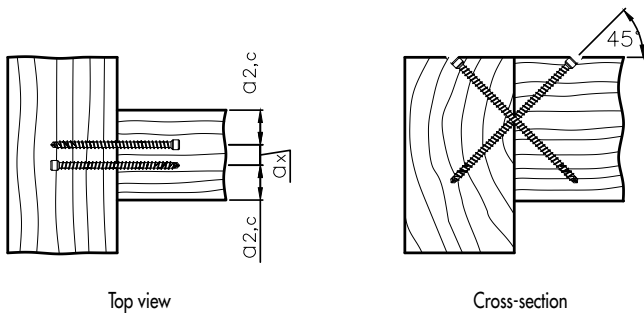

### SCREWS USED AT AN ANGLE THAT RUNS PERPENDICULAR TO THE WOOD GRAIN

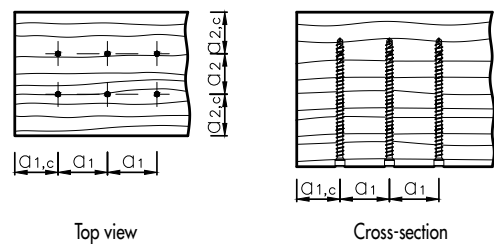

### SCREWS UNDER TENSILE LOAD USED AT AN ANGLE α THAT RUNS OBLIQUELY TO THE WOOD GRAIN

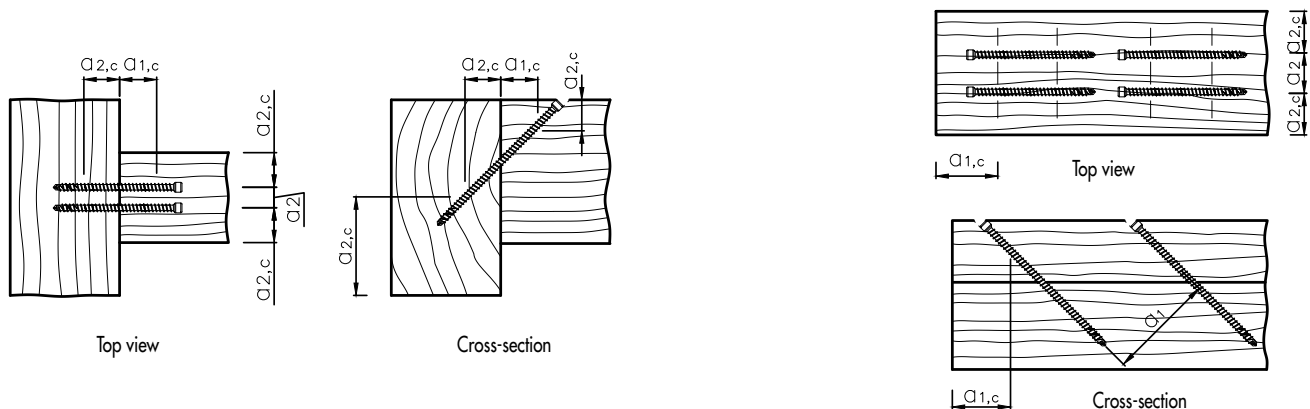

KonstruX ST fully threaded screw  
Cylinder head, Drill tip, blue galvanised

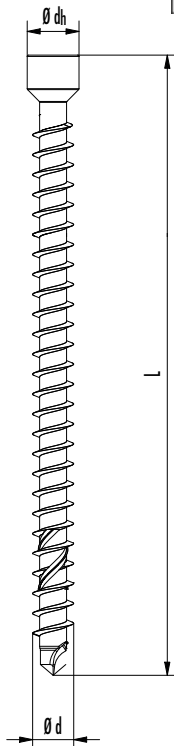

Art. no.	Dimension [mm]	Drive	PU
<b>Ø 5,2 mm</b>			
100425	5,2 x 80	TX 25 ●	100
100427	5,2 x 100	TX 25 ●	100
100428	5,2 x 120	TX 25 ●	100
100430	5,2 x 140	TX 25 ●	100
100431	5,2 x 160	TX 25 ●	100
<b>Ø 5,9 mm</b>			
100410	5,9 x 80	TX30 ●	100
100412	5,9 x 100	TX30 ●	100
100413	5,9 x 120	TX30 ●	100
100415	5,9 x 140	TX30 ●	100
100416	5,9 x 160	TX30 ●	100
100417	5,9 x 180	TX30 ●	100
100418	5,9 x 200	TX30 ●	100
<b>Ø 6,5 mm</b>			
904808	6,5 x 80	TX30 ●	100
904809	6,5 x 100	TX30 ●	100
904810	6,5 x 120	TX30 ●	100
904811	6,5 x 140	TX30 ●	100
904812	6,5 x 160	TX30 ●	100
904813	6,5 x 195	TX30 ●	100
100063 <sup>a)</sup>	6,5 x 200	TX30 ●	100
100064 <sup>a)</sup>	6,5 x 220	TX30 ●	100
100065 <sup>a)</sup>	6,5 x 240	TX30 ●	100
100066 <sup>a)</sup>	6,5 x 260	TX30 ●	100
<b>Ø 8,0 mm</b>			
954081	8,0 x 125	TX40 ●	50
904825	8,0 x 155	TX40 ●	50
904826	8,0 x 195	TX40 ●	50
904827	8,0 x 220	TX40 ●	50
904828	8,0 x 245	TX40 ●	50
904834	8,0 x 270	TX40 ●	50
904829	8,0 x 295	TX40 ●	50
904830	8,0 x 330	TX40 ●	50
904831	8,0 x 375	TX40 ●	50
904832	8,0 x 400	TX40 ●	50
944804	8,0 x 430	TX40 ●	50
944805	8,0 x 480	TX40 ●	50
944806	8,0 x 530	TX40 ●	50
944807	8,0 x 580	TX40 ●	50
<b>Ø 10,0 mm</b>			
904872	10,0 x 195	TX50 ●	25
904873	10,0 x 220	TX50 ●	25
904874	10,0 x 245	TX50 ●	25
904875	10,0 x 270	TX50 ●	25
904815	10,0 x 300	TX50 ●	25
904816	10,0 x 330	TX50 ●	25
904817	10,0 x 360	TX50 ●	25
904818	10,0 x 400	TX50 ●	25
904819	10,0 x 450	TX50 ●	25
904820	10,0 x 500	TX50 ●	25
904821	10,0 x 550	TX50 ●	25
904822	10,0 x 600	TX50 ●	25
100080 <sup>a)</sup>	10,0 x 650	TX50 ●	25
100081 <sup>a)</sup>	10,0 x 700	TX50 ●	25
100082 <sup>a)</sup>	10,0 x 750	TX50 ●	25
100083 <sup>a)</sup>	10,0 x 800	TX50 ●	25
100084 <sup>a)</sup>	10,0 x 900	TX50 ●	25
100085 <sup>a)</sup>	10,0 x 1000	TX50 ●	25

<sup>a)</sup> European Technical Assessment (ETA) has been applied for.

**KonstruX ST fully threaded screw**

Countersunk head, screw tip AG,  
blue galvanised



NKL 1 – 2

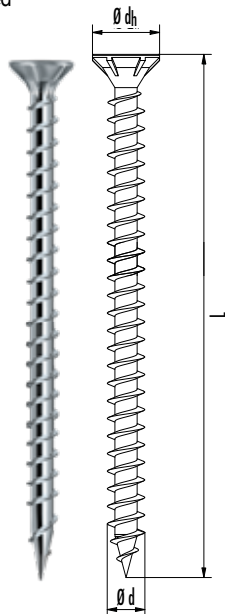

Art. no.	Ø d [mm]	L [mm]	Ø dh [mm]	Drive	PU
905737	11,3	300	18,0	TX50 •	20
905738	11,3	340	18,0	TX50 •	20
905739	11,3	380	18,0	TX50 •	20
905740	11,3	420	18,0	TX50 •	20
905741	11,3	460	18,0	TX50 •	20
905742	11,3	500	18,0	TX50 •	20
905743	11,3	540	18,0	TX50 •	20
905744	11,3	580	18,0	TX50 •	20
905745	11,3	620	18,0	TX50 •	20
905746	11,3	660	18,0	TX50 •	20
905747	11,3	700	18,0	TX50 •	20
905748	11,3	750	18,0	TX50 •	20
905749	11,3	800	18,0	TX50 •	20
904750	11,3	900	18,0	TX50 •	20
904751	11,3	1000	18,0	TX50 •	20

KonstruX ST fully threaded screw  
Countersunk head, Drill tip, blue galvanised



NKL 1 - 2

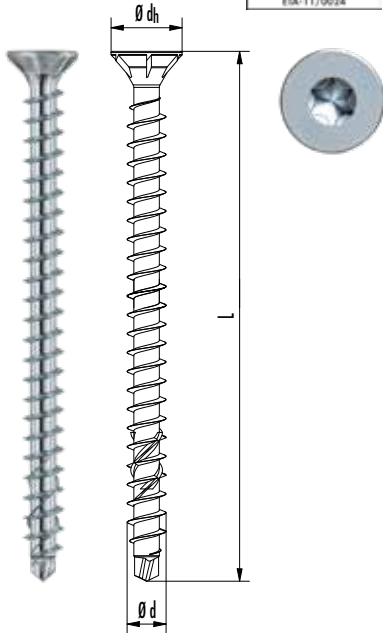

Art. no.	Dimension [mm]	Drive	PU
<b>Ø 5,2 mm</b>			
904876	5,2 x 80	TX25 •	100
904878	5,2 x 100	TX25 •	100
904879	5,2 x 120	TX25 •	100
904907	5,2 x 140	TX25 •	100
904908	5,2 x 160	TX25 •	100
<b>Ø 6,5 mm</b>			
904857	6,5 x 80	TX30 •	100
904858	6,5 x 100	TX30 •	100
904859	6,5 x 120	TX30 •	100
904860	6,5 x 140	TX30 •	100
<b>Ø 8,0 mm</b>			
904790	8,0 x 95	TX40 •	50
904791	8,0 x 125	TX40 •	50
904792	8,0 x 155	TX40 •	50
904793	8,0 x 195	TX40 •	50
904794	8,0 x 220	TX40 •	50
904795	8,0 x 245	TX40 •	50
904796	8,0 x 270	TX40 •	50
904797	8,0 x 295	TX40 •	50
904798	8,0 x 330	TX40 •	50
904799	8,0 x 375	TX40 •	50
904800	8,0 x 400	TX40 •	50
904801	8,0 x 430	TX40 •	50
904802	8,0 x 480	TX40 •	50
904803	8,0 x 545	TX40 •	50
<b>Ø 10,0 mm</b>			
904770	10,0 x 125	TX50 •	25
904771	10,0 x 155	TX50 •	25
904772	10,0 x 195	TX50 •	25
904773	10,0 x 220	TX50 •	25
904774	10,0 x 245	TX50 •	25
904775	10,0 x 270	TX50 •	25
904776	10,0 x 300	TX50 •	25
904777	10,0 x 330	TX50 •	25
904778	10,0 x 360	TX50 •	25
904779	10,0 x 400	TX50 •	25
904780	10,0 x 450	TX50 •	25
904781	10,0 x 500	TX50 •	25
904782	10,0 x 550	TX50 •	25
904783	10,0 x 600	TX50 •	25
100090	10,0 x 650	TX50 •	25
100091	10,0 x 700	TX50 •	25
100092	10,0 x 750	TX50 •	25
100093	10,0 x 800	TX50 •	25
100094	10,0 x 900	TX50 •	25
100095	10,0 x 1000	TX50 •	25

# KONSTRUX FULLY THREADED SCREW

Stainless steel A4

KonstruX ST A4 fully threaded screws maximize connection load-bearing capacity by providing high thread extraction resistance in both components, whereas partially threaded screws are limited by the much lower head pull-through resistance in the attachment part. As a result, KonstruX fully threaded screws offer a cost-effective alternative to traditional carpentry joints as well as timber connectors such as joist hangers.

Suitable for use in timber-timber connections in both indoor and outdoor settings. The application areas of KonstruX ST A4 screws are to be found outdoors in timber bridges, playgrounds, on balconies, in sun protection applications in the shape of pergolas as well as near the coast and in hydraulic engineering, e.g. on jetties and piers.

KonstruX ST fully threaded screw  
Cylinder head, Drill tip, stainless steel A4



- A4
- NKL 1 – 3
- CRC III
- C5
- T5

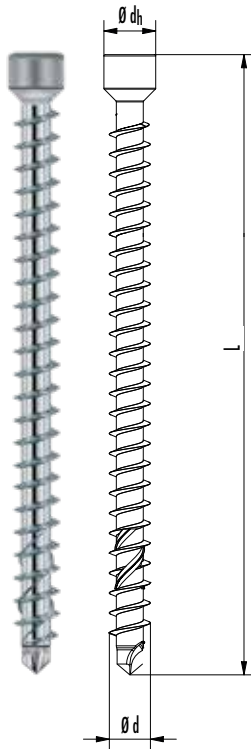

Art. no.	Ø d [mm]	L [mm]	Ø dh [mm]	Drive	PU
944780	6,5	140	8,0	TX40 ●	100
944781	6,5	160	8,0	TX40 ●	100
944782	6,5	195	8,0	TX40 ●	100
944783	8,0	155	8,0	TX40 ●	50
944784	8,0	195	8,0	TX40 ●	50
944785	8,0	220	8,0	TX40 ●	50
944786	8,0	245	8,0	TX40 ●	50
944787	8,0	270	8,0	TX40 ●	50
944788	8,0	295	8,0	TX40 ●	50
944789	8,0	330	8,0	TX40 ●	50
944790	8,0	375	8,0	TX40 ●	50
944791	8,0	400	8,0	TX40 ●	50

KonstruX A4							
Geometric properties					Mechanical properties		
Nominal Ød [mm]	Root Øi [mm]	Head <sup>a)</sup> Øh [mm]	Head depth <sup>a)</sup> hh [mm]	Tip type	ftens,k [kN]	fax,k [MPa]	My,k [Nm]
6,5	4,5	8,0	5,5	Drill tip	10,0	15,5	10,0
8	5,2	14,5 / 10	7,4 / 6,5	AG / Drill tip	14,0	12,5	16,0
10	5,9	17,8	8,7	AG	20,0	11,5	26,0

<sup>a)</sup> Countersunk head / Cylinder head. Ø6,5 and 8 mm are only available as a countersunk head.

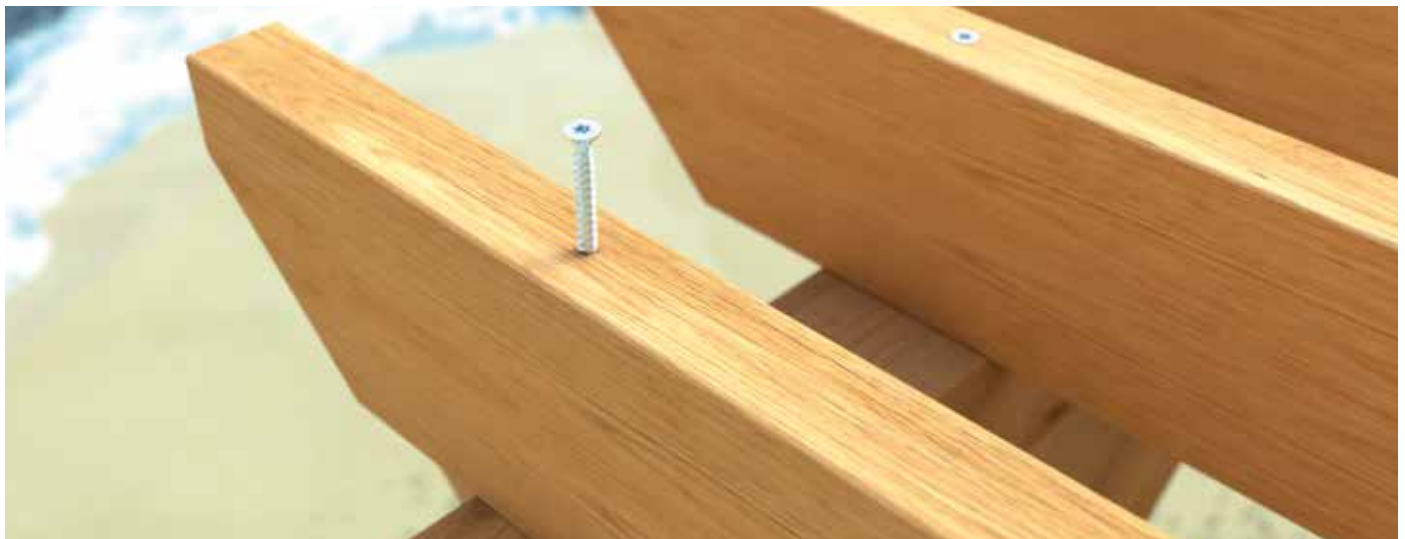

KonstruX with countersunk head stainless steel A4: Ideal for timber-timber connections in polluted urban and industrial areas > 0.25 km from the coast.

**KonstruX ST fully threaded screw**  
Countersunk head, Drill tip, stainless steel A4



- 
- 
- 
- 
- 

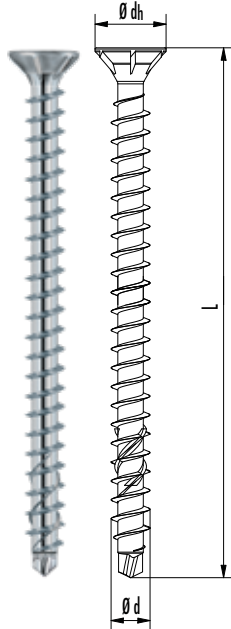

Art. no.	Ø d [mm]	L [mm]	Ø dh [mm]	Drive	PU
944795	8,0	95	14,5	TX40 ●	50
944792	8,0	125	14,5	TX40 ●	50
944793	8,0	155	14,5	TX40 ●	50
944794	8,0	195	14,5	TX40 ●	50

**KonstruX fully threaded screw**  
Countersunk head, stainless steel A4



- 
- 
- 
- 
- 

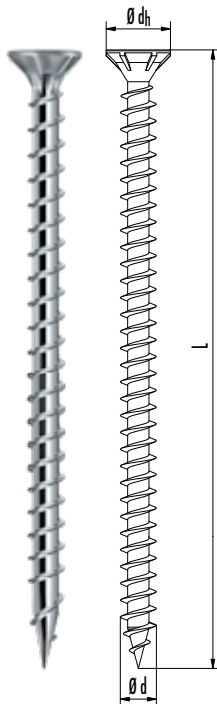

Art. no.	Ø d [mm]	L [mm]	Ø dh [mm]	Drive	PU
905750	10,0	160	17,8	TX50 ●	25
905751	10,0	200	17,8	TX50 ●	25
905752	10,0	220	17,8	TX50 ●	25
905753	10,0	240	17,8	TX50 ●	25
905754	10,0	260	17,8	TX50 ●	25
905755	10,0	280	17,8	TX50 ●	25
905756	10,0	300	17,8	TX50 ●	25
905757	10,0	350	17,8	TX50 ●	25
905758	10,0	400	17,8	TX50 ●	25

**NEW**

# KONSTRUX DUO

Fully threaded screw with contraction effect



The KonstruX DUO is an innovative fully threaded screw that combines the best characteristics of fully and partially threaded screws by **maintaining the load-bearing capacity** of the connection via the equal extraction resistance in both structural components. KonstruX DUO screws have a limited corrosion-resistance and **can be used in the service classes 1 and 2 according to DIN EN 1995 (Eurocode 5)**.

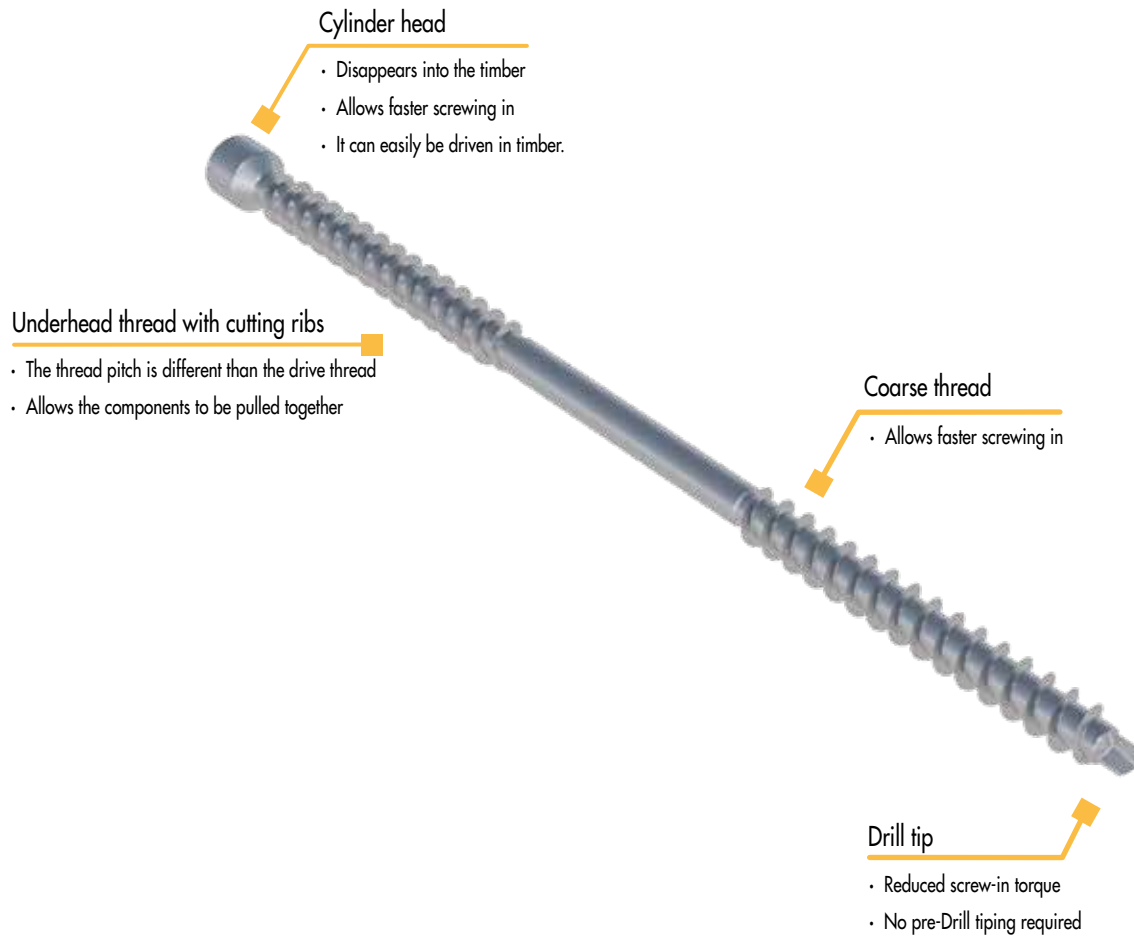

KonstruX DUO								
Geometric properties						Mechanical properties		
Nominal Ø [mm]	Root Ø <sub>i</sub> [mm]	Head <sup>a)</sup> Ø <sub>h</sub> [mm]	Shaft Ø <sub>s</sub> [mm]	Head depth <sup>a)</sup> hh [mm]	Tip type	f <sub>tens,k</sub> [kN]	f <sub>ax,k</sub> [MPa]	M <sub>y,k</sub> [Nm]
6,5	4,5	8,0	5,0	5,5	Drill tip	17,0	4,0	15,0
8	5,2	10	5,8	6,5	Drill tip	25,0	11,1	25,0

<sup>a)</sup> Cylinder head

### KonstruX DUO

Cylinder head, Drill tip, steel blue galvanised



SC 1-2

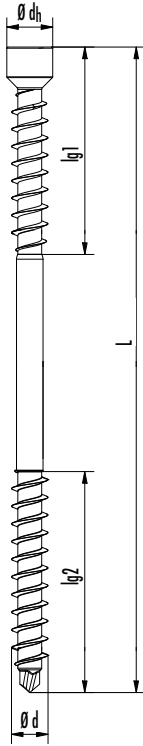

Art. no.	Ø d [mm]	L [mm]	Ø dh [mm]	lg1 / lg2 [mm]	Drive	PU
100606	6,5	90	8,0	40/40	TX30 ●	50
100607	6,5	130	8,0	43/43	TX30 ●	50
100608	6,5	160	8,0	67/67	TX30 ●	50
100609	6,5	190	8,0	82/82	TX30 ●	50
100610	6,5	220	8,0	97/97	TX30 ●	50
100611	8,0	160	10,0	67/67	TX40 ●	50
100612	8,0	190	10,0	92/92	TX40 ●	50
100613	8,0	220	10,0	92/92	TX40 ●	50
100614	8,0	245	10,0	107/107	TX40 ●	50
100615	8,0	280	10,0	107/107	TX40 ●	50
100616	8,0	300	10,0	137/137	TX40 ●	50
100617	8,0	330	10,0	137/137	TX40 ●	50
100618	8,0	400	10,0	137/137	TX40 ●	50

### APPLICATION EXAMPLES



KonstruX DUO for the construction of a stair stringer



KonstruX DUO sectional view between two structural components



KonstruX DUO for the fastening of a covering



KonstruX DUO for the fastening of a joist

# KONSTRUX, 13 mm E12

For the reinforcement of large span timber structures

**KonstruX screws with an E12 drive** are widely used in large span timber construction, thanks to the **high thread-extraction resistance** in both structural components. With a coarse thread across their entire length and an outer diameter of 13 mm, these screws are designed to have an **excellent axial extraction resistance** in structural timber components. With their **impressive tensile strength of 75 kN**, the screws can take full advantage of their maximum length of 1,400 mm and are therefore particularly suitable for the reinforcement of large span wooden girder or arches.

Typical applications are to be found in glue-laminated timber elements or hall trusses with large spans, beam and connection reinforcements, transverse tensile reinforcements, recess reinforcements on notches, opening reinforcements and support reinforcements in order to increase, maintain or restore the load-bearing capacity and reduce long-term deformations.

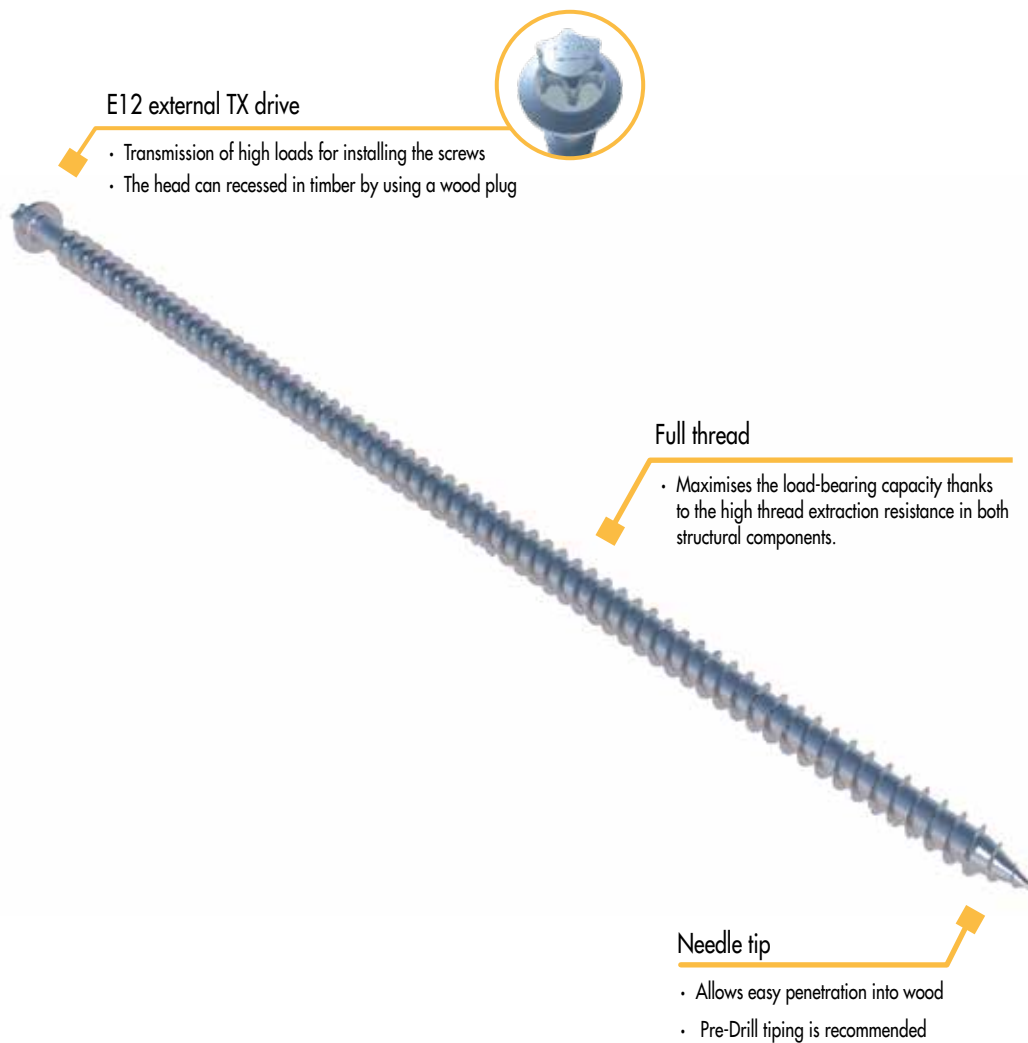

KonstruX E12 Carbon Steel							
Geometric properties					Mechanical properties		
Nominal $\varnothing$ [mm]	Root $\varnothing_i$ [mm]	Head <sup>a)</sup> $\varnothing_h$ [mm]	Head depth <sup>a)</sup> hh [mm]	Tip type	$f_{tens,k}$ [kN]	$f_{ax,k}$ [MPa]	$M_{y,k}$ [Nm]
13	9,2	18,0	10,0	AG	75,0	10,8	120,0

<sup>a)</sup> E12 external head



**Konstrux, 13 mm E12**

E12 external TX drive, blue galvanised



SC 1-2

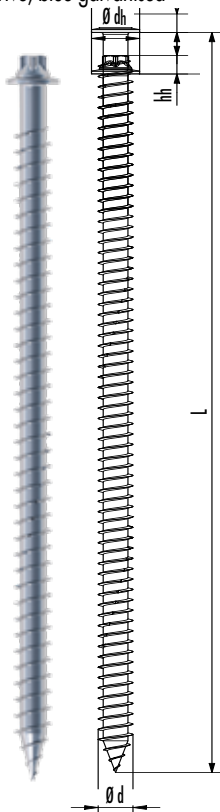

Art. no.	Ø d [mm]	L [mm]	Ø dh [mm]	hh [mm]	Drive	PU
904840	13,0	300	18	10	TX50 •	20
904841	13,0	320	18	10	TX50 •	20
904842	13,0	340	18	10	TX50 •	20
904843	13,0	360	18	10	TX50 •	20
904844	13,0	380	18	10	TX50 •	20
904845	13,0	420	18	10	TX50 •	20
904846	13,0	460	18	10	TX50 •	20
904847	13,0	500	18	10	TX50 •	20
904848	13,0	540	18	10	TX50 •	20
904849	13,0	580	18	10	TX50 •	20
904850	13,0	620	18	10	TX50 •	20
904851	13,0	660	18	10	TX50 •	20
904852	13,0	700	18	10	TX50 •	20
904853	13,0	750	18	10	TX50 •	20
904854	13,0	800	18	10	TX50 •	20
904855	13,0	900	18	10	TX50 •	20
904856	13,0	1000	18	10	TX50 •	20
904861 <sup>a)</sup>	13,0	1200	18	10	TX50 •	20
904862 <sup>a)</sup>	13,0	1400	18	10	TX50 •	20

<sup>a)</sup> European Technical Assessment (ETA) has been applied for.

**1/2" external TX socket**



**Suitable to this**

Art. no.	Drive	PU
800420	E12	1

**REINFORCEMENT EXAMPLES**



Reinforcement of beam openings

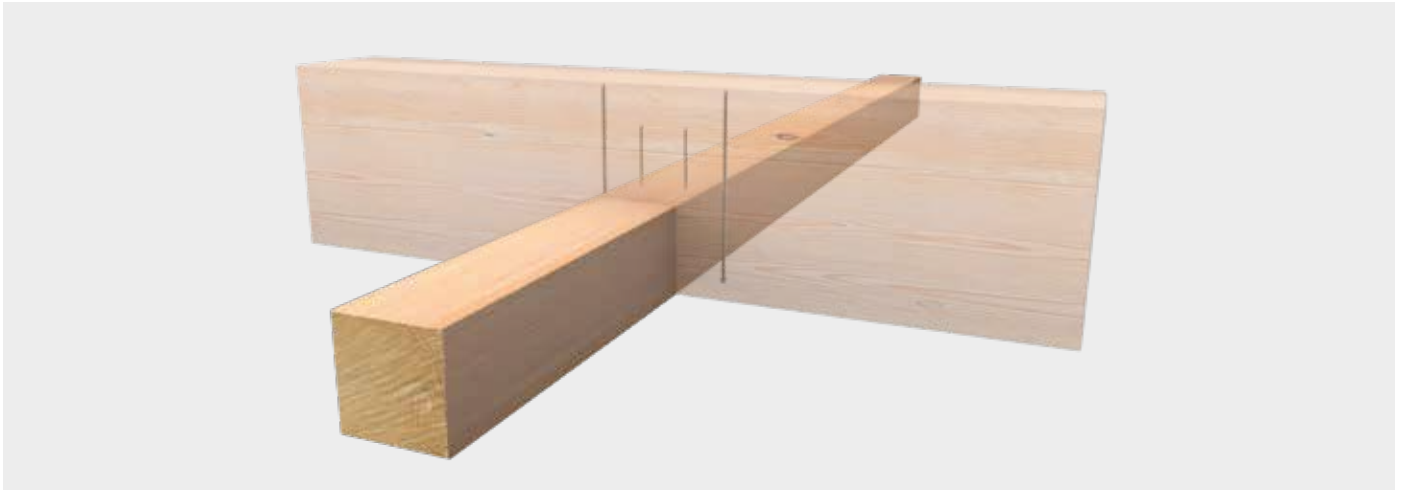

*Reinforcement of the main/secondary beam supports*



*Reinforcement of notched beams*



*Reinforcement of trapezoidally shaped beams*

## CLT FLOOR-TO-FLOOR JOINTS

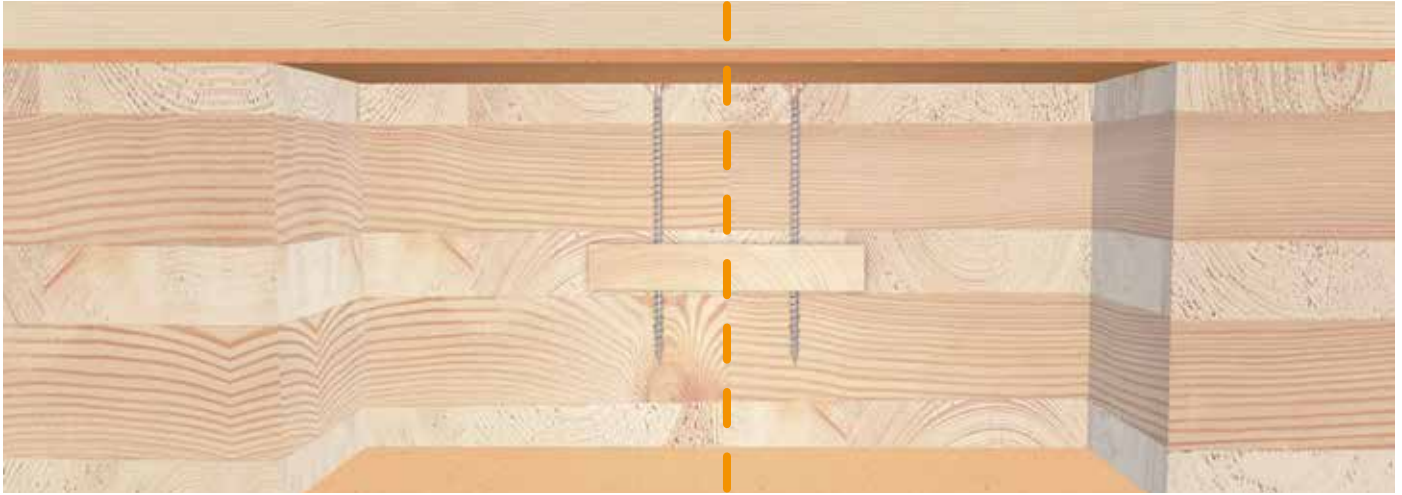

*Connection of ceiling elements through internal push board*

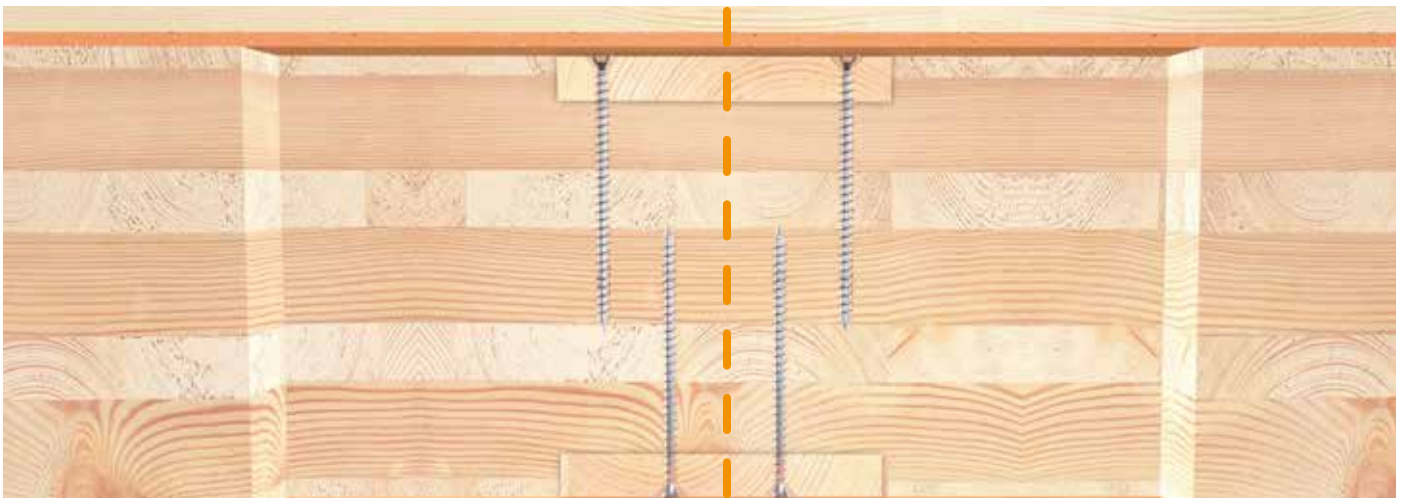

*Connection of ceiling elements through double push board*

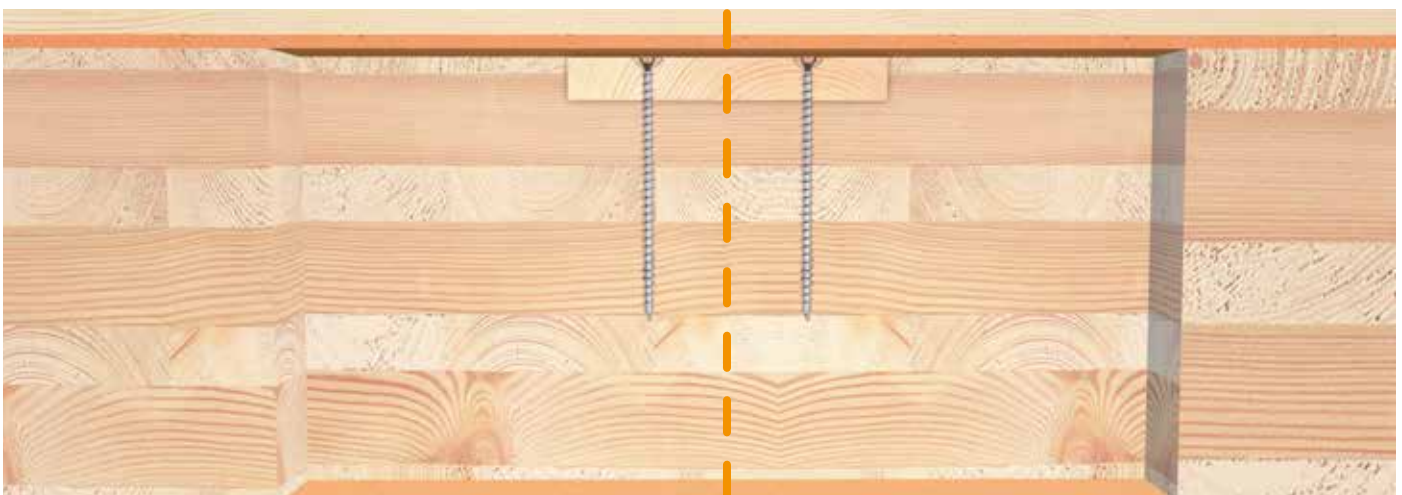

*Connection of ceiling elements through upper push board*

## CLT WALL-TO-FLOOR JOINTS

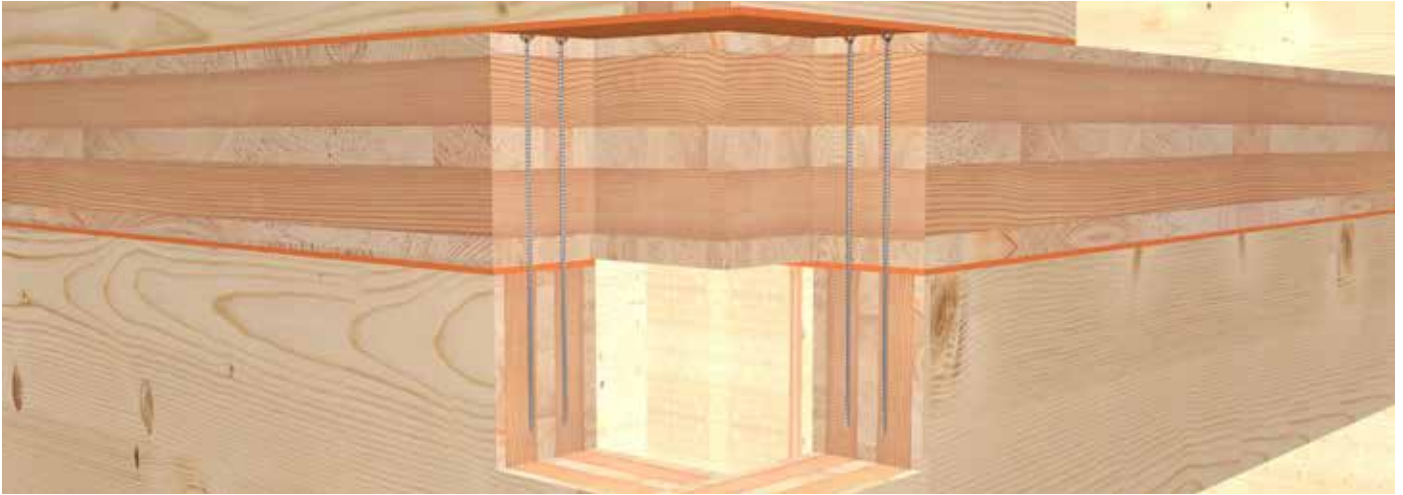

Connection of wall- and ceiling elements



Connection of a wall with the wooden floor of the upper level

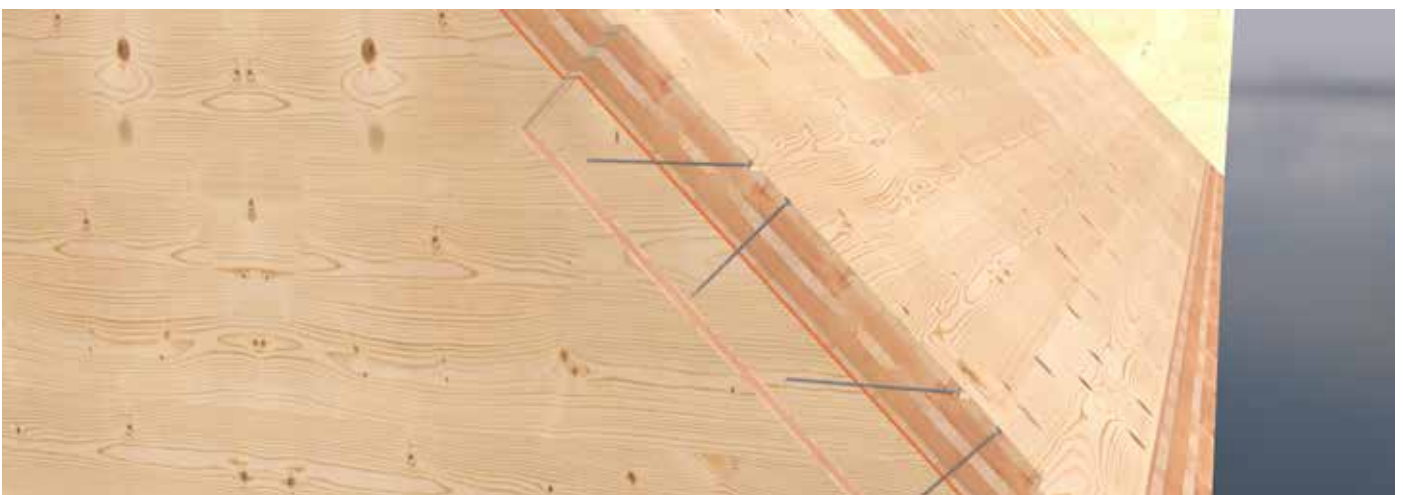

Connection of roof- and wall elements

## STAIRCASE CONSTRUCTION WITH CLT PANELS



*Attach the stair tread support to the wall.*

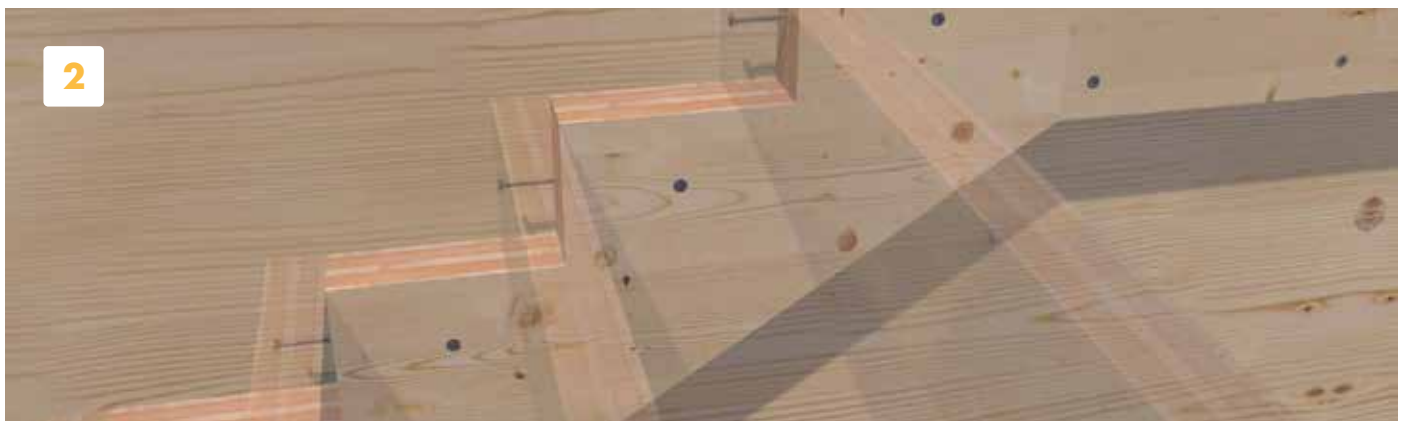

*Attach the stringer to the front of the stair tread support using screws.*



*Attach the stair treads on top to the stringer.*



*Done!*



# ANGLE-BRACKET SCREW (ABS)

For quick and easy screwing on steel plates

The Eurotec angle-bracket screw (ABS) **made of hardened carbon has been specially designed for connections between sheet steel and wood.** The **splitting effect in the wood is reduced** by the geometry of the screw tip. In addition, the screw is characterised, among other things, by the **smooth shank that sits directly beneath its head** which allows for the **transmission of high shear loads in steel plates.**

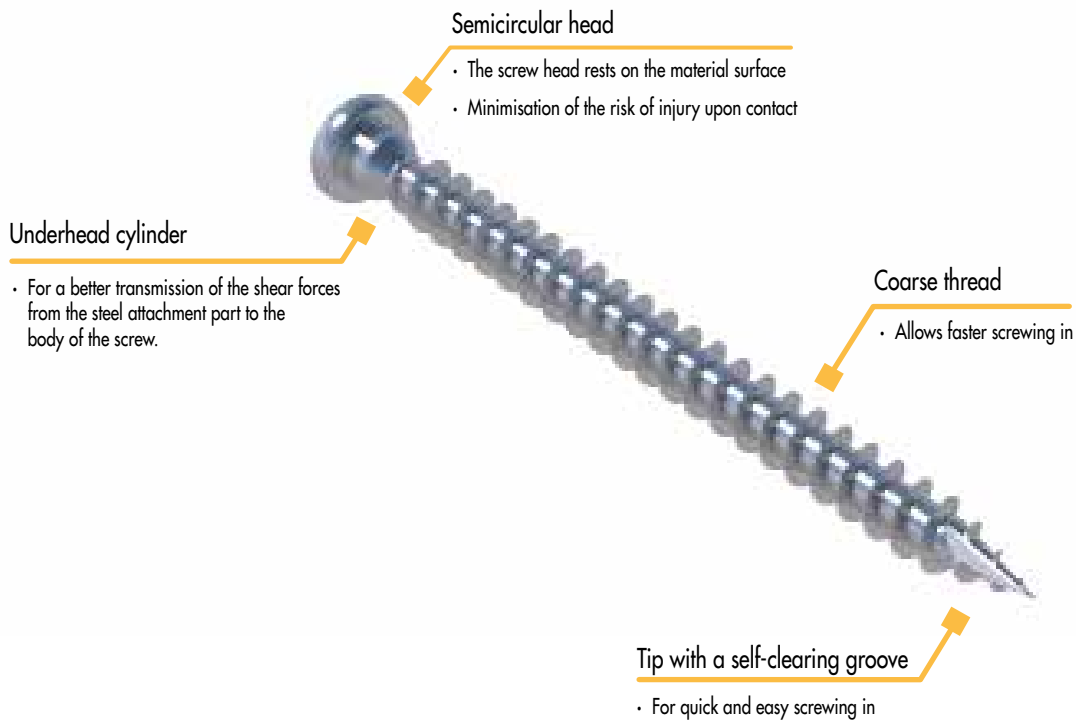



**Angle-bracket screw**

Steel, blue galvanised

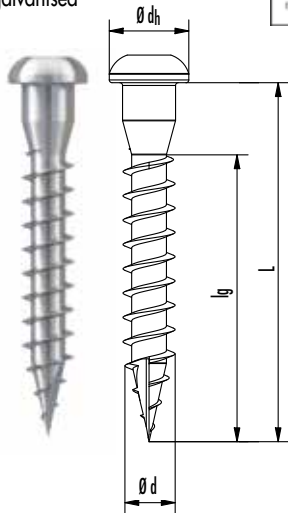

Art. no.	Ø d [mm]	L [mm]	lg [mm]	Ø dh [mm]	Drive	PU
945343	5,0	25	16	7,2	TX20	250
945232	5,0	35	26	7,2	TX20	250
945241	5,0	40	31	7,2	TX20	250
945233	5,0	50	41	7,2	TX20	250
945344	5,0	60	51	7,2	TX20	250
945345	5,0	70	61	7,2	TX20	250

**ABS and ABS Strong Carbon Steel**

Geometric properties					Mechanical properties		
Nominal Ø [mm]	Root Øi [mm]	Neck Øn [mm]	Steel Øhole [mm]	Head Øh [mm]	ftens,k [kN]	fak,k [MPa]	My,k [Nm]
5	3,2	4,8	5,0	7,2	7,9	12,1	5,9
8	5,2	10,0	11,0	13,5	20,0	12,5	20,0
10	5,9	12,0	13,0	16,5	33,0	11,5	40,0

**Angle-bracket screw A4**

Stainless steel A4

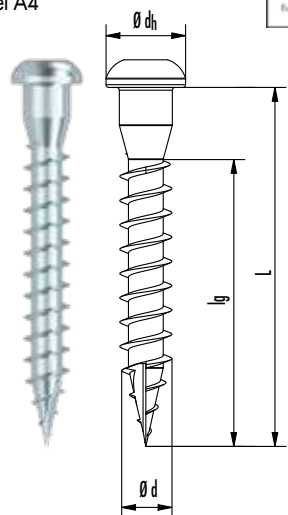

Art. no.	Ø d [mm]	L [mm]	lg [mm]	Ø dh [mm]	Drive	PU
945621	5,0	35	26	7,2	TX20	250
945622	5,0	40	31	7,2	TX20	250
945623	5,0	50	41	7,2	TX20	250
945625	5,0	60	51	7,2	TX20	250

**ABS Stainless Steel A4**

Geometric properties					Mechanical properties		
Nominal Ø [mm]	Root Øi [mm]	Neck Øn [mm]	Steel Øhole [mm]	Head Øh [mm]	ftens,k [kN]	fak,k [MPa]	My,k [Nm]
5	3,2	4,8	5,0	7,2	6,2	12,1	4,3

Angle-bracket screw ZK Hard-wood

Steel, blue galvanised



SC1-2

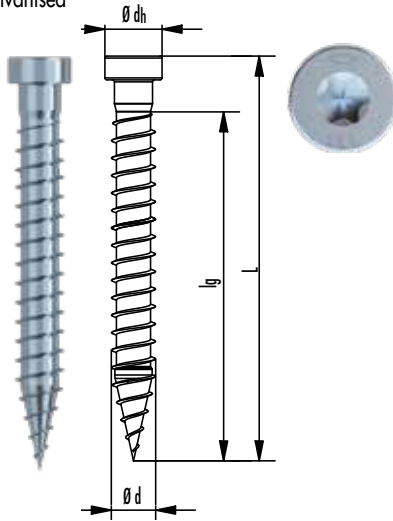

Art. no.	Ø d [mm]	L [mm]	lg [mm]	Ø dh [mm]	Drive	PU
945383	5,5	35	31	7,2	TX20 ●	250
945384	5,5	40	36	7,2	TX20 ●	250
945385	5,5	50	46	7,2	TX20 ●	250
945386	5,5	60	56	7,2	TX20 ●	250
945387	5,5	70	61	7,2	TX20 ●	250

ABS Hardwood LBS Carbon Steel

Geometric properties					Mechanical properties		
Nominal Ø [mm]	Root Øi [mm]	Neck Øn [mm]	Steel Øhole [mm]	Head Øh [mm]	ftens,k [kN]	fax,k [MPa]	My,k [Nm]
5,6	4,3	4,8	5,0	7,2	14,0	12,1 / 15 / 31 / 40	13,0

Angle-bracket screw Strong

Steel, blue galvanised



SC1-2

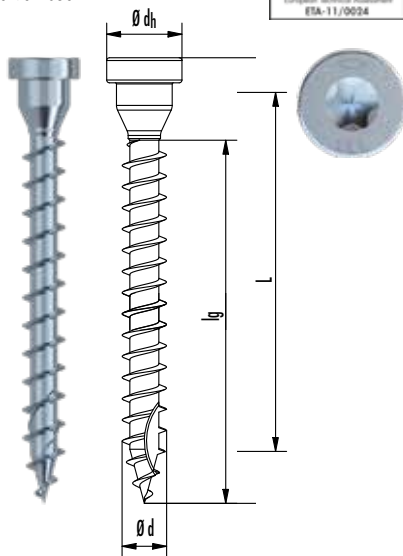

Art. no.	Ø d [mm]	L [mm]	lg [mm]	Ø dh [mm]	Drive	PU
975815	8,0	60	50	13,5	TX40 ●	50
975816	8,0	80	70	13,5	TX40 ●	50
975817	8,0	100	90	13,5	TX40 ●	50
975818	8,0	120	110	13,5	TX40 ●	50
975819	8,0	140	130	13,5	TX40 ●	50
975820	8,0	160	150	13,5	TX40 ●	50
975821	10,0	80	67,5	16,5	TX50 ●	50
975822	10,0	100	87,5	16,5	TX50 ●	50
975823	10,0	120	107,5	16,5	TX50 ●	50
975824	10,0	140	127,5	16,5	TX50 ●	50
975825	10,0	160	147,5	16,5	TX50 ●	50
975826	10,0	180	167,5	16,5	TX50 ●	50

# ANCHOR NAIL

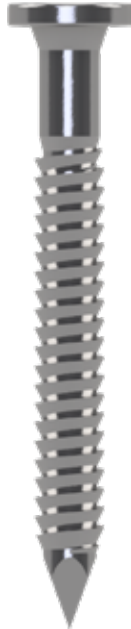

Art. no.	Dimensions Ød x L [mm]	Material	PU
200240	4,0 x 40	Electrogalvanised	250
200241	4,0 x 50	Electrogalvanised	250
200242	4,0 x 60	Electrogalvanised	250
200243*	4,0 x 40	Electrogalvanised	2000
200244*	4,0 x 50	Electrogalvanised	2000
200245*	4,0 x 60	Electrogalvanised	2000

\*Magazined version

Anchor Nail							
Geometric properties					Mechanical properties		
Ø x L [mm]	Root Øi [mm]	Shank Øs [mm]	Head Øh [mm]	Threaded length with tip [mm]	ftens,k [kN]	fax,k [MPa]	My,k [Nm]
4 x 40	3,4	3,9	8,0	30,0	8,0	4,84	6,5
4 x 50	3,4	3,9	8,0	40,0	8,0	5,09	6,5
4 x 60	3,4	3,9	8,0	50,0	8,0	5,23	6,5



# PANELTWISTEC

Paneltwistec are wood construction screws with a special screw tip and milling ribs above the thread. The cutting notch on the screw tip ensures that it grips quickly and reduces the splitting effect during screwing in. Paneltwistec AG on the other hand features a folded-down thread, which reduces the screw-in resistance. Paneltwistec wood screws are available with countersunk, ornamental or washer heads as well as in coated carbon steel and a number of stainless steels.

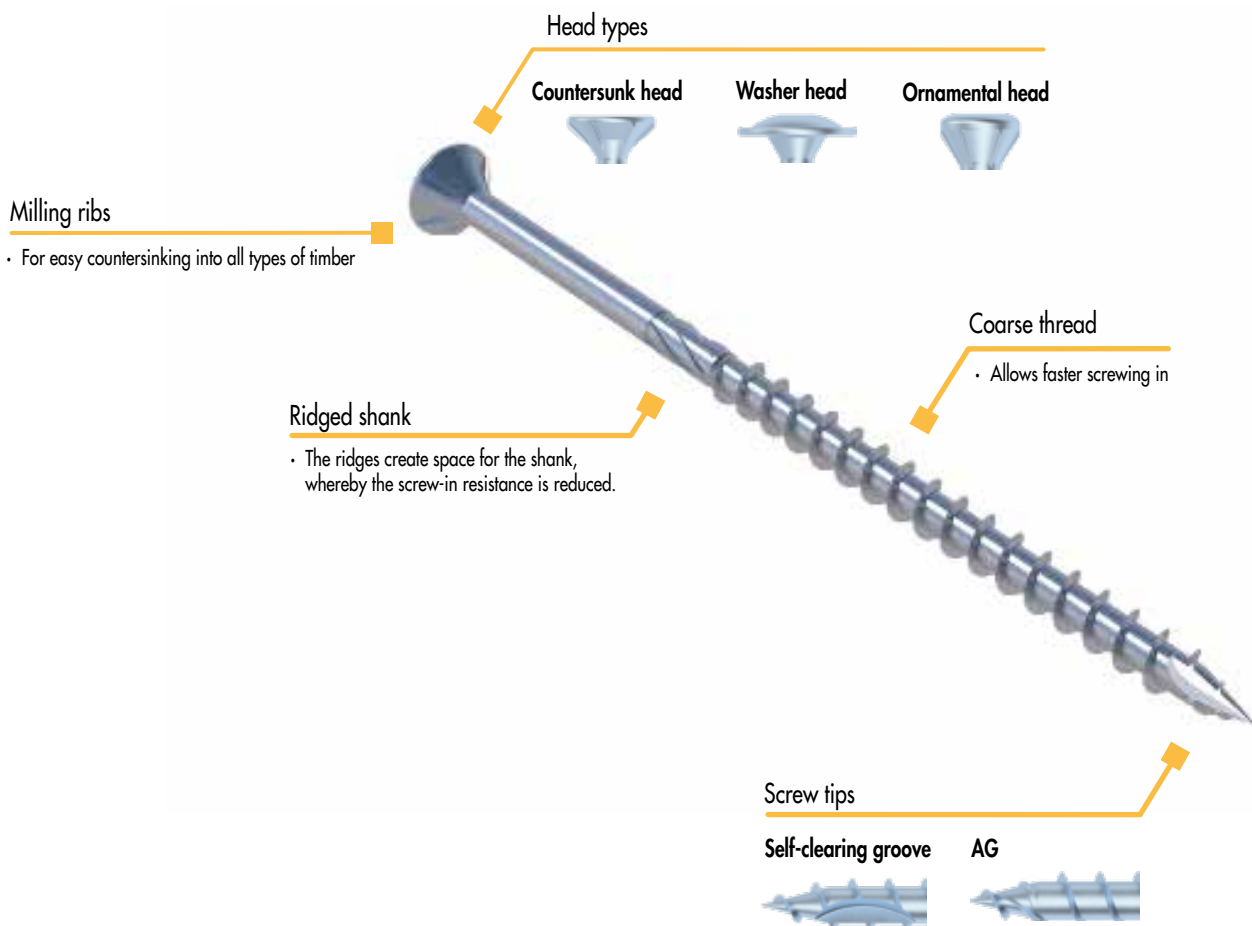

Paneltwistec Carbon Steel

Geometric properties					Mechanical properties			
Nominal Ø [mm]	Root Ø <sub>i</sub> [mm]	Shaft Ø <sub>s</sub> [mm]	Head <sup>a)</sup> Ø <sub>h</sub> [mm]	Thread length [mm]	f <sub>tens,k</sub> [kN]	f <sub>ax,k</sub> [MPa]	f <sub>head,k</sub> [MPa]	M <sub>y,k</sub> [Nm]
3,5	2,1	2,3	7,0	12 – 27	3,8	13,3	12,0	2,3
4	2,5	2,8	8,0/10,0	16 – 48	5,0	12,9	12,0	3,3
4,5	2,7	3,0	9,0/11,0	16 – 60	6,4	12,5	12,0	4,5
5	3,3	4,6	10,0/12,0	25 – 70	7,9	12,1	12,0	5,9
6	4,0	4,3	12,0/14,0	24 – 70	11,0	11,4	12,0	9,5
8	5,3	5,7	14,5/22,0	32 – 100	20,0	11,1	12,0	20,0
10	6,3	6,9	18,0/25,0	40 – 100	28,0	10,8	12,0	35,8
12	7,1	8,1	20,0	80 – 120	25,0	10,8	12,0	40,0

<sup>a)</sup> Countersunk head / Washer head



## PANELTWISTEC AG, COUNTERSUNK HEAD SCREW

### Paneltwistec AG

Countersunk head, screw tip AG,  
blue galvanised



NKL 1 - 2

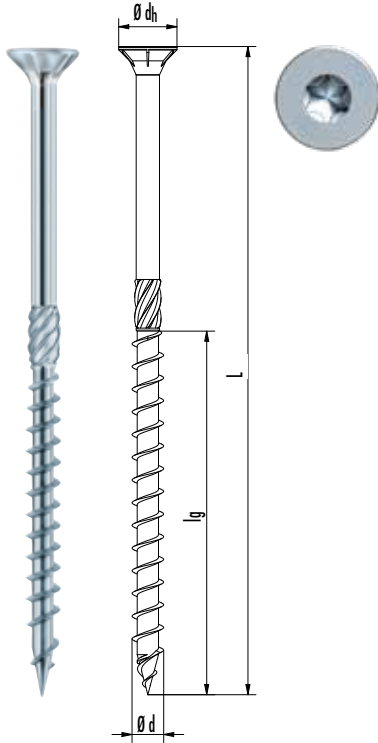

Art. no.	Ø d [mm]	L [mm]	Ø dh [mm]	lg [mm]	Drive	PU
945436	3,5	30	7,0	18	TX15 ●	1000
945838	3,5	35	7,0	21	TX15 ●	1000
945437	3,5	40	7,0	24	TX15 ●	1000
945490	3,5	50	7,0	30	TX15 ●	500
945491	4,0	30	8,0	18	TX20 ●	1000
945836	4,0	35	8,0	21	TX20 ●	1000
945492	4,0	40	8,0	24	TX20 ●	1000
945493	4,0	45	8,0	27	TX20 ●	500
945494	4,0	50	8,0	30	TX20 ●	500
945495	4,0	60	8,0	36	TX20 ●	200
945496	4,0	70	8,0	42	TX20 ●	200
945497	4,0	80	8,0	48	TX20 ●	200
945498	4,5	40	9,0	24	TX25 ●	500
945588	4,5	45	9,0	27	TX25 ●	500
945499	4,5	50	9,0	30	TX25 ●	500
945567	4,5	60	9,0	36	TX25 ●	200
945568	4,5	70	9,0	42	TX25 ●	200
945569	4,5	80	9,0	48	TX25 ●	200
945574	5,0	40	10,0	24	TX25 ●	200
945574-TX40*	5,0	40	9,5	24	TX40 ●	200
945837	5,0	45	10,0	27	TX25 ●	200
945575	5,0	50	10,0	30	TX25 ●	200
945575-TX40*	5,0	50	9,5	30	TX40 ●	200
945576	5,0	60	10,0	36	TX25 ●	200
945576-TX40*	5,0	60	9,5	36	TX40 ●	200
945577	5,0	70	10,0	42	TX25 ●	200
945577-TX40*	5,0	70	9,5	42	TX40 ●	200
945578	5,0	80	10,0	48	TX25 ●	200
945578-TX40*	5,0	80	9,5	48	TX40 ●	200
945579	5,0	90	10,0	54	TX25 ●	200
945579-TX40*	5,0	90	9,5	54	TX40 ●	200
945580	5,0	100	10,0	60	TX25 ●	200
945580-TX40*	5,0	100	9,5	60	TX40 ●	200
945581	5,0	120	10,0	70	TX25 ●	200
945600	5,0	50	10,0	30	TX30 ●	200*
945601	5,0	60	10,0	36	TX30 ●	200*
945602	5,0	70	10,0	42	TX30 ●	200*
945603	5,0	80	10,0	48	TX30 ●	200*
945604	5,0	90	10,0	54	TX30 ●	200*
945605	5,0	100	10,0	60	TX30 ●	200*
945607	5,0	120	10,0	70	TX30 ●	200*
945581-TX40*	5,0	120	9,5	70	TX40 ●	200
945583	6,0	60	12,0	36	TX30 ●	200
945584	6,0	70	12,0	42	TX30 ●	200
945632	6,0	80	12,0	48	TX30 ●	200
945633	6,0	90	12,0	54	TX30 ●	100
945634	6,0	100	12,0	60	TX30 ●	100
945635	6,0	110	12,0	70	TX30 ●	100
945636	6,0	120	12,0	70	TX30 ●	100
945637	6,0	130	12,0	70	TX30 ●	100
945638	6,0	140	12,0	70	TX30 ●	100
945639	6,0	150	12,0	70	TX30 ●	100
945640	6,0	160	12,0	70	TX30 ●	100
945641	6,0	180	12,0	70	TX30 ●	100
945642	6,0	200	12,0	70	TX30 ●	100
945643	6,0	220	12,0	70	TX30 ●	100
945644	6,0	240	12,0	70	TX30 ●	100
945645	6,0	260	12,0	70	TX30 ●	100
945646	6,0	280	12,0	70	TX30 ●	100
945647	6,0	300	12,0	70	TX30 ●	100

\*Screw head may differ from the image

Paneltwistec AG

Countersunk head, screw tip AG,  
steel blue galvanised

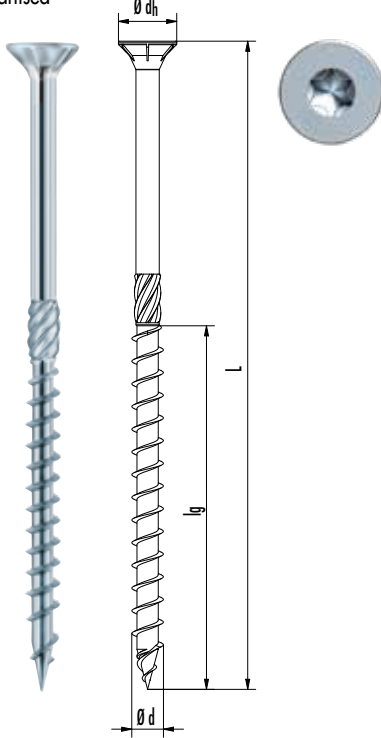

Art. no.	Ø d [mm]	L [mm]	Ø dh [mm]	lg [mm]	Drive	PU
945630-TX40*	6,0	60	12,0	36	TX40 ●	200
945631-TX40*	6,0	70	12,0	42	TX40 ●	200
945632-TX40*	6,0	80	12,0	48	TX40 ●	200
945633-TX40*	6,0	90	12,0	54	TX40 ●	200
945634-TX40*	6,0	100	12,0	60	TX40 ●	100
945636-TX40*	6,0	120	12,0	70	TX40 ●	100
945638-TX40*	6,0	140	12,0	70	TX40 ●	100
945640-TX40*	6,0	160	12,0	70	TX40 ●	100
945641-TX40*	6,0	180	12,0	70	TX40 ●	100
945642-TX40*	6,0	200	12,0	70	TX40 ●	100
945643-TX40*	6,0	220	12,0	70	TX40 ●	100
945644-TX40*	6,0	240	12,0	70	TX40 ●	100
945645-TX40*	6,0	260	12,0	70	TX40 ●	100
945646-TX40*	6,0	280	12,0	70	TX40 ●	100
945647-TX40*	6,0	300	12,0	70	TX40 ●	100
945648	6,0	320	12,0	70	TX30 ●	100
945649	6,0	340	12,0	70	TX30 ●	100
945650	6,0	360	12,0	70	TX30 ●	100
945651	6,0	380	12,0	70	TX30 ●	100
945652	6,0	400	12,0	70	TX30 ●	100
944715	8,0	80	14,5	48	TX40 ●	50
944716	8,0	100	14,5	60	TX40 ●	50
944717	8,0	120	14,5	66	TX40 ●	50
944718	8,0	140	14,5	95	TX40 ●	50
944719	8,0	160	14,5	95	TX40 ●	50
944720	8,0	180	14,5	95	TX40 ●	50
944721	8,0	200	14,5	95	TX40 ●	50
944722	8,0	220	14,5	95	TX40 ●	50
944723	8,0	240	14,5	95	TX40 ●	50
944724	8,0	260	14,5	95	TX40 ●	50
944725	8,0	280	14,5	95	TX40 ●	50
944726	8,0	300	14,5	95	TX40 ●	50
944727	8,0	320	14,5	95	TX40 ●	50
944728	8,0	340	14,5	95	TX40 ●	50
944729	8,0	360	14,5	95	TX40 ●	50
944730	8,0	380	14,5	95	TX40 ●	50
944731	8,0	400	14,5	95	TX40 ●	50
944732	8,0	420	14,5	95	TX40 ●	50
944733	8,0	440	14,5	95	TX40 ●	50
944734	8,0	460	14,5	95	TX40 ●	25
944735	8,0	480	14,5	95	TX40 ●	25
944736	8,0	500	14,5	95	TX40 ●	25
944737	8,0	550	14,5	95	TX40 ●	25
944739	8,0	600	14,5	95	TX40 ●	25
945687	10,0	100	17,8	60	TX50 ●	50
945688	10,0	120	17,8	70	TX50 ●	50
945689	10,0	140	17,8	80	TX50 ●	50
945690	10,0	160	17,8	90	TX50 ●	50
945691	10,0	180	17,8	100	TX50 ●	50
945692	10,0	200	17,8	100	TX50 ●	50
945693	10,0	220	17,8	100	TX50 ●	50
945694	10,0	240	17,8	100	TX50 ●	50
945695	10,0	260	17,8	100	TX50 ●	50
945696	10,0	280	17,8	100	TX50 ●	50
945697	10,0	300	17,8	100	TX50 ●	50
945698	10,0	320	17,8	100	TX50 ●	50
945699	10,0	340	17,8	100	TX50 ●	50
945703	10,0	360	17,8	100	TX50 ●	50
945709	10,0	380	17,8	100	TX50 ●	50
945711	10,0	400	17,8	100	TX50 ●	50
100036	10,0	420	17,8	100	TX50 ●	25
100037	10,0	440	17,8	100	TX50 ●	25
100038	10,0	460	17,8	100	TX50 ●	25
100039	10,0	480	17,8	100	TX50 ●	25
100040	10,0	500	17,8	100	TX50 ●	25
100041	10,0	550	17,8	100	TX50 ●	25
100042	10,0	600	17,8	100	TX50 ●	25

\*Screw head may differ from the image

# PANELTWISTEC AG, WASHER HEAD SCREW

Blue galvanised

## Paneltwistec AG

Washer head screw, screw tip AG,  
blue galvanised



NKL 1 – 2

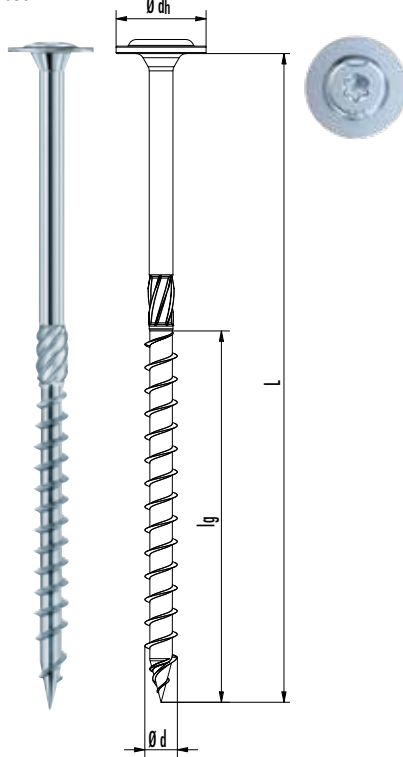

Art. no.	Ø d [mm]	L [mm]	Ø dh [mm]	lg [mm]	Drive	PU
946158	4,0	40	10,0	24	TX20 ●	500
946159	4,0	50	10,0	30	TX20 ●	500
946160	4,0	60	10,0	36	TX20 ●	500
946161	4,5	50	11,0	30	TX20 ●	200
946162	4,5	60	11,0	36	TX20 ●	200
946163	4,5	70	11,0	42	TX20 ●	200
946037	5,0	50	12,0	30	TX25 ●	200
946038	5,0	60	12,0	36	TX25 ●	200
946039	5,0	70	12,0	42	TX25 ●	200
946040	5,0	80	12,0	48	TX25 ●	200
946042	5,0	100	12,0	60	TX25 ●	200
945947	6,0	30	14,0	30	TX30 ●	100
945948	6,0	40	14,0	40	TX30 ●	100
945712	6,0	50	14,0	30	TX30 ●	100
945713	6,0	60	14,0	36	TX30 ●	100
945713-TX40	6,0	60	15,0	36	TX40 ●	100
945716	6,0	70	14,0	42	TX30 ●	100
945717	6,0	80	14,0	48	TX30 ●	100
945717-TX40	6,0	80	15,0	48	TX40 ●	100
945718	6,0	90	14,0	54	TX30 ●	100
945719	6,0	100	14,0	60	TX30 ●	100
945719-TX40	6,0	100	15,0	60	TX40 ●	100
945720	6,0	110	14,0	70	TX30 ●	100
945721	6,0	120	14,0	70	TX30 ●	100
945721-TX40	6,0	120	15,0	70	TX40 ●	100
945722	6,0	130	14,0	70	TX30 ●	100
945723	6,0	140	14,0	70	TX30 ●	100
945723-TX40	6,0	140	15,0	70	TX40 ●	100
945724	6,0	150	14,0	70	TX30 ●	100
945725	6,0	160	14,0	70	TX30 ●	100
945725-TX40	6,0	160	15,0	70	TX40 ●	100
945726	6,0	180	14,0	70	TX30 ●	100
945726-TX40	6,0	180	15,0	70	TX40 ●	100
945727	6,0	200	14,0	70	TX30 ●	100
945727-TX40	6,0	200	15,0	70	TX40 ●	100
945728	6,0	220	14,0	70	TX30 ●	100
945728-TX40	6,0	220	15,0	70	TX40 ●	100
945729	6,0	240	14,0	70	TX30 ●	100
945729-TX40	6,0	240	15,0	70	TX40 ●	100
945730	6,0	260	14,0	70	TX30 ●	100
945731	6,0	280	14,0	70	TX30 ●	100
945732	6,0	300	14,0	70	TX30 ●	100
945733	6,0	320	12,0	70	TX30 ●	100
945734	6,0	340	12,0	70	TX30 ●	100
945735	6,0	360	12,0	70	TX30 ●	100
945736	6,0	380	12,0	70	TX30 ●	100
945737	6,0	400	12,0	70	TX30 ●	100
945806	8,0	60	22,0	48	TX40 ●	50
944588	8,0	80	22,0	48	TX40 ●	50
944589	8,0	100	22,0	60	TX40 ●	50
944590	8,0	120	22,0	66	TX40 ●	50
944591	8,0	140	22,0	95	TX40 ●	50
944592	8,0	160	22,0	95	TX40 ●	50
944593	8,0	180	22,0	95	TX40 ●	50

# PANELTWISTEC AG, WASHER HEAD SCREW

## Paneltwistec AG

Washer head screw, screw tip AG,  
blue galvanised



NKL 1-2

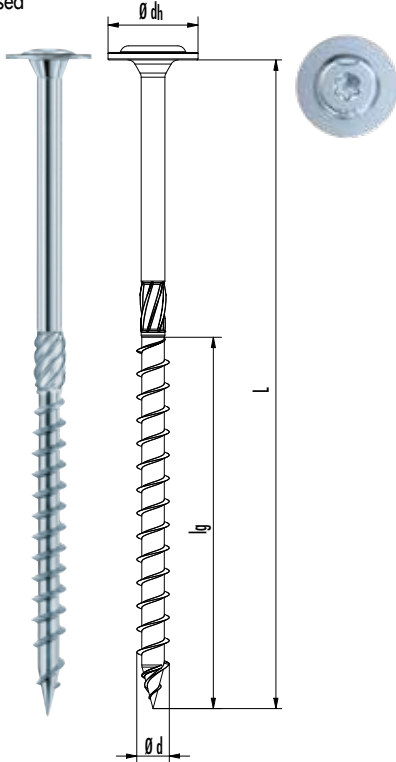

Art. no.	Ø d [mm]	L [mm]	Ø dh [mm]	lg [mm]	Drive	PU
944594	8,0	200	22,0	95	TX40 ●	50
944595	8,0	220	22,0	95	TX40 ●	50
944596	8,0	240	22,0	95	TX40 ●	50
944597	8,0	260	22,0	95	TX40 ●	50
944598	8,0	280	22,0	95	TX40 ●	50
944599	8,0	300	22,0	95	TX40 ●	50
944600	8,0	320	22,0	95	TX40 ●	50
944601	8,0	340	22,0	95	TX40 ●	50
944602	8,0	360	22,0	95	TX40 ●	50
944603	8,0	380	22,0	95	TX40 ●	50
944603	8,0	380	22,0	95	TX40 ●	50
944604	8,0	400	22,0	95	TX40 ●	50
944605	8,0	420	22,0	95	TX40 ●	25
944606	8,0	440	22,0	95	TX40 ●	25
944607	8,0	460	22,0	95	TX40 ●	25
944608	8,0	480	22,0	95	TX40 ●	25
944609	8,0	500	22,0	95	TX40 ●	25
944610	8,0	550	22,0	95	TX40 ●	25
944611	8,0	600	22,0	95	TX40 ●	25
945750	10,0	80	25,0	50	TX50 ●	50
945751	10,0	100	25,0	60	TX50 ●	50
945752	10,0	120	25,0	70	TX50 ●	50
945753	10,0	140	25,0	80	TX50 ●	50
945754	10,0	160	25,0	90	TX50 ●	50
945755	10,0	180	25,0	100	TX50 ●	50
945756	10,0	200	25,0	100	TX50 ●	50
945757	10,0	220	25,0	100	TX50 ●	50
945758	10,0	240	25,0	100	TX50 ●	50
945759	10,0	260	25,0	100	TX50 ●	50
945760	10,0	280	25,0	100	TX50 ●	50
945761	10,0	300	25,0	100	TX50 ●	50
945762	10,0	320	25,0	100	TX50 ●	50
945763	10,0	340	25,0	100	TX50 ●	50
945764	10,0	360	25,0	100	TX50 ●	25
945765	10,0	380	25,0	100	TX50 ●	25
945766	10,0	400	25,0	100	TX50 ●	25
100019	10,0	420	17,8	100	TX50 ●	25
100020	10,0	440	17,8	100	TX50 ●	25
100021	10,0	460	17,8	100	TX50 ●	25
100022	10,0	480	17,8	100	TX50 ●	25
100023	10,0	500	17,8	100	TX50 ●	25
100024	10,0	550	17,8	100	TX50 ●	25
100025	10,0	600	17,8	100	TX50 ●	25

# PANELTWISTEC

Steel blue galvanised

## Paneltwistec

Countersunk head, screw tip with self-clearing groove, steel blue galvanised

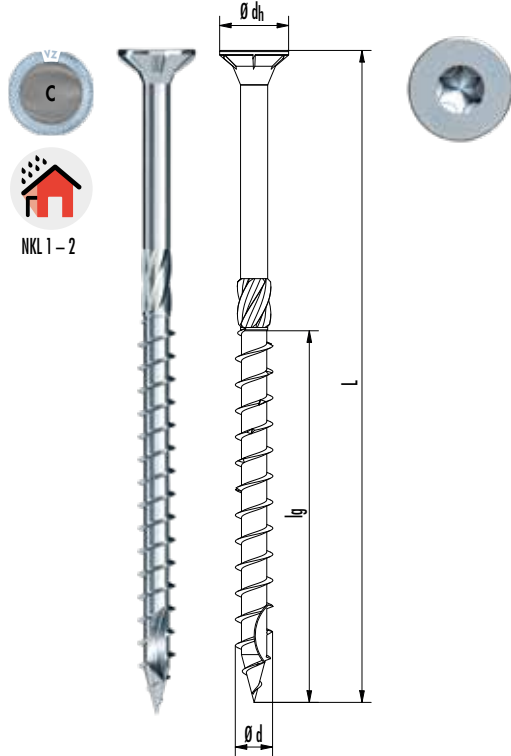

Art. no.	Ø d [mm]	L [mm]	Ø dh [mm]	lg [mm]	Drive	PU
B903045	3,5	30	7,0	18	TX15 ●	1000
B903044	3,5	35	7,0	21	TX15 ●	1000
B903001	3,5	40	7,0	24	TX15 ●	1000
B903002	3,5	50	7,0	30	TX15 ●	500
B903003	4,0	30	8,0	18	TX20 ●	1000
B903603	4,0	35	8,0	21	TX20 ●	1000
B903004	4,0	40	8,0	24	TX20 ●	1000
B902089	4,0	45	8,0	27	TX20 ●	500
B903005	4,0	50	8,0	30	TX20 ●	500
B903006	4,0	60	8,0	36	TX20 ●	200
B903007	4,0	70	8,0	42	TX20 ●	200
B903008	4,0	80	8,0	48	TX20 ●	200
B903009	4,5	40	9,0	24	TX25 ●	500
B903087	4,5	45	9,0	27	TX25 ●	500
B903010	4,5	50	9,0	30	TX25 ●	500
B903088	4,5	55	9,0	36	TX25 ●	500
B903011	4,5	60	9,0	36	TX25 ●	200
B903012	4,5	70	9,0	42	TX25 ●	200
B903013	4,5	80	9,0	48	TX25 ●	200
B903014	5,0	40	10,0	24	TX25 ●	200
B903015	5,0	50	10,0	30	TX25 ●	200
B903016	5,0	60	10,0	36	TX25 ●	200
B903017	5,0	70	10,0	42	TX25 ●	200
B903018	5,0	80	10,0	48	TX25 ●	200
B903578	5,0	90	10,0	54	TX25 ●	200
B903019	5,0	100	10,0	60	TX25 ●	200
B903020	5,0	120	10,0	70	TX25 ●	200
B903021	6,0	60	12,0	36	TX30 ●	200
B903022	6,0	70	12,0	42	TX30 ●	200
B903023	6,0	80	12,0	48	TX30 ●	200
B903163	6,0	90	12,0	54	TX30 ●	100
B903024	6,0	100	12,0	60	TX30 ●	100
B903025	6,0	120	12,0	70	TX30 ●	100
B903026	6,0	130	12,0	70	TX30 ●	100
B903027	6,0	140	12,0	70	TX30 ●	100
B903030	6,0	150	12,0	70	TX30 ●	100
B903029	6,0	160	12,0	70	TX30 ●	100
B903031	6,0	180	12,0	70	TX30 ●	100
B903032	6,0	200	12,0	70	TX30 ●	100
B903033	6,0	220	12,0	70	TX30 ●	100
B903034	6,0	240	12,0	70	TX30 ●	100
B903035	6,0	260	12,0	70	TX30 ●	100
B903036	6,0	280	12,0	70	TX30 ●	100
B903037	6,0	300	12,0	70	TX30 ●	100

other sizes on the next page

Paneltwistec

Countersunk head, screw tip with self-clearing groove, steel blue galvanised

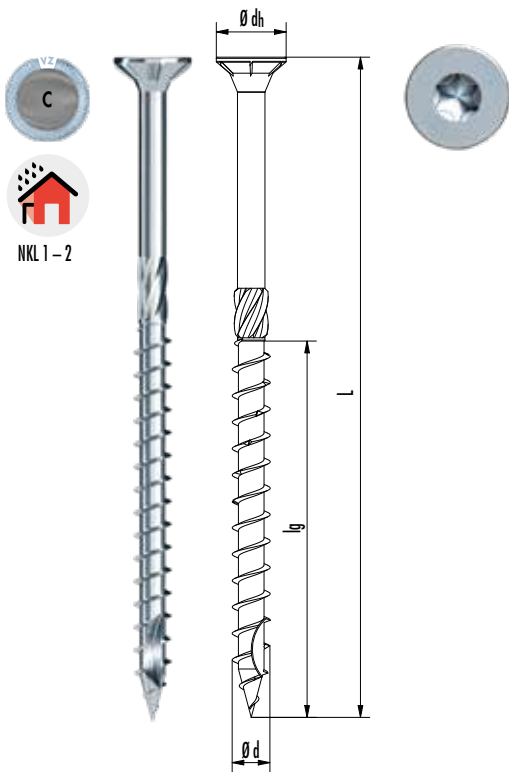

Art. no.	Ø d [mm]	L [mm]	Ø dh [mm]	lg [mm]	Drive	PU
903443	8,0	80	14,5	48	TX40 ●	1000
903435	8,0	100	14,5	60	TX40 ●	1000
903419	8,0	120	14,5	66	TX40 ●	1000
903420	8,0	140	14,5	95	TX40 ●	500
903421	8,0	160	14,5	95	TX40 ●	1000
903422	8,0	180	14,5	95	TX40 ●	1000
903423	8,0	200	14,5	95	TX40 ●	1000
903424	8,0	220	14,5	95	TX40 ●	500
903425	8,0	240	14,5	95	TX40 ●	1000
903426	8,0	260	14,5	95	TX40 ●	200
903427	8,0	280	14,5	95	TX40 ●	200
903428	8,0	300	14,5	95	TX40 ●	200
903429	8,0	320	14,5	95	TX40 ●	500
903430	8,0	340	14,5	95	TX40 ●	500
903431	8,0	360	14,5	95	TX40 ●	500
903432	8,0	380	14,5	95	TX40 ●	500
903433	8,0	400	14,5	95	TX40 ●	200
975780	12,0	120	20,0	80	TX50 ●	25
975781	12,0	140	20,0	80	TX50 ●	25
975782	12,0	160	20,0	80	TX50 ●	25
975783	12,0	180	20,0	80	TX50 ●	25
975784	12,0	200	20,0	80	TX50 ●	25
975785	12,0	220	20,0	100	TX50 ●	25
975786	12,0	240	20,0	100	TX50 ●	25
975787	12,0	260	20,0	100	TX50 ●	25
975788	12,0	280	20,0	100	TX50 ●	25
975789	12,0	300	20,0	100	TX50 ●	25
975790	12,0	320	20,0	100	TX50 ●	25
975791	12,0	340	20,0	120	TX50 ●	25
975792	12,0	360	20,0	120	TX50 ●	25
975793	12,0	380	20,0	120	TX50 ●	25
975794	12,0	400	20,0	120	TX50 ●	25
975795	12,0	500	20,0	120	TX50 ●	25
975796	12,0	600	20,0	120	TX50 ●	25

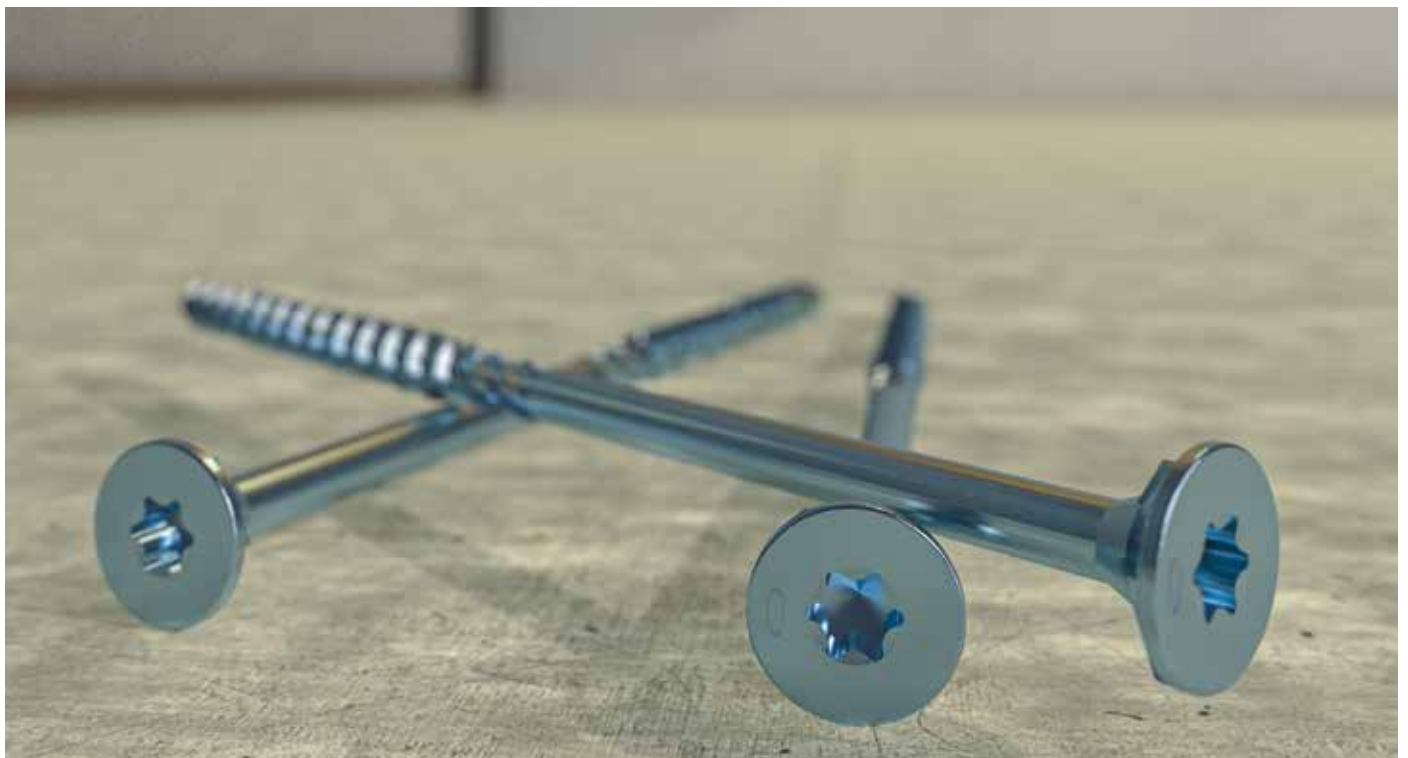

# PANELTWISTEC

Steel yellow galvanised

## Paneltwistec

Countersunk head, screw tip with self-clearing groove, steel yellow galvanised

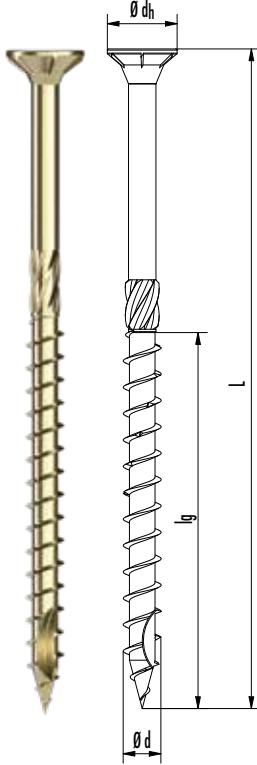

Art. no.	Ø d [mm]	L [mm]	Ø dh [mm]	lg [mm]	Drive	PU
903000	3,5	30	7,0	18	TX20	1000
903044	3,5	35	7,0	21	TX20	1000
903001	3,5	40	7,0	24	TX20	1000
903002	3,5	50	7,0	30	TX20	500
903003	4,0	30	8,0	18	TX20	1000
903603	4,0	35	8,0	21	TX20	1000
903004	4,0	40	8,0	24	TX20	1000
902089	4,0	45	8,0	27	TX20	500
903005	4,0	50	8,0	30	TX20	500
903006	4,0	60	8,0	36	TX20	200
903007	4,0	70	8,0	42	TX20	200
903008	4,0	80	8,0	48	TX20	200
903046	4,5	35	9,0	24	TX20	500
903009	4,5	40	9,0	27	TX20	500
903087	4,5	45	9,0	30	TX20	500
903010	4,5	50	9,0	36	TX20	500
903011	4,5	60	9,0	42	TX20	200
903012	4,5	70	9,0	48	TX20	200
903013	4,5	80	9,0	24	TX20	200
903014	5,0	40	10,0	27	TX20	200
903015	5,0	50	10,0	30	TX20	200
903016	5,0	60	10,0	36	TX20	200
903017	5,0	70	10,0	42	TX20	200
903018	5,0	80	10,0	48	TX20	200
903578	5,0	90	10,0	54	TX20	200
903019	5,0	100	10,0	60	TX20	200
903020	5,0	120	10,0	70	TX20	200
903071	5,0	40	10,0	24	TX25	200
903072	5,0	50	10,0	30	TX25	200
903073	5,0	60	10,0	36	TX25	200
903074	5,0	70	10,0	42	TX25	200
903075	5,0	80	10,0	48	TX25	200
903582	5,0	90	10,0	54	TX25	200
903076	5,0	100	10,0	60	TX25	200
903077	5,0	120	10,0	70	TX25	200
903021	6,0	60	12,0	36	TX30	200
903022	6,0	70	12,0	42	TX30	200
903023	6,0	80	12,0	48	TX30	200
903163	6,0	90	12,0	54	TX30	100
903024	6,0	100	12,0	60	TX30	100
903039	6,0	110	12,0	70	TX30	100
903025	6,0	120	12,0	70	TX30	100
903026	6,0	130	12,0	70	TX30	100
903027	6,0	140	12,0	70	TX30	100
903028	6,0	150	12,0	70	TX30	100
903029	6,0	160	12,0	70	TX30	100
903031	6,0	180	12,0	70	TX30	100
903032	6,0	200	12,0	70	TX30	100
903033	6,0	220	12,0	70	TX30	100
903034	6,0	240	12,0	70	TX30	100
903035	6,0	260	12,0	70	TX30	100
903036	6,0	280	12,0	70	TX30	100
903037	6,0	300	12,0	70	TX30	100
903550	8,0	80	14,5	48	TX40	50
903551	8,0	100	14,5	60	TX40	50
902920	8,0	120	14,5	80	TX40	50
902919	8,0	140	14,5	80	TX40	50
902921	8,0	160	14,5	80	TX40	50



**Paneltwistec**

Countersunk head, screw tip with self-clearing groove, steel yellow galvanised

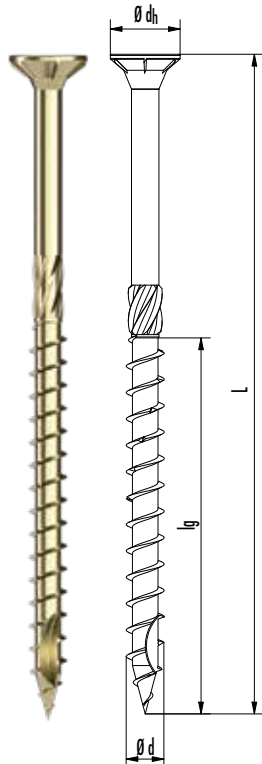

Art. no.	Ø d [mm]	L [mm]	Ø dh [mm]	lg [mm]	Drive	PU
902922	8,0	180	14,5	80	TX40 ●	50
902923	8,0	200	14,5	80	TX40 ●	50
902924	8,0	220	14,5	80	TX40 ●	50
902925	8,0	240	14,5	80	TX40 ●	50
902926	8,0	260	14,5	80	TX40 ●	50
902928	8,0	300	14,5	80	TX40 ●	50
902929	8,0	320	14,5	80	TX40 ●	50
902930	8,0	340	14,5	80	TX40 ●	50
902931	8,0	360	14,5	80	TX40 ●	50
902932	8,0	380	14,5	80	TX40 ●	50
903030	8,0	400	14,5	80	TX40 ●	50
903513	10,0	100	17,4	60	TX50 ●	50
903491	10,0	120	17,4	90	TX50 ●	50
903492	10,0	140	17,4	90	TX50 ●	50
903493	10,0	160	17,4	90	TX50 ●	50
903494	10,0	180	17,4	90	TX50 ●	50
903495	10,0	200	17,4	90	TX50 ●	50
903496	10,0	220	17,4	90	TX50 ●	50
903497	10,0	240	17,4	90	TX50 ●	50
903498	10,0	260	17,4	90	TX50 ●	50
903499	10,0	280	17,4	90	TX50 ●	50
903500	10,0	300	17,4	90	TX50 ●	50
903501	10,0	320	17,4	90	TX50 ●	50
903502	10,0	340	17,4	90	TX50 ●	50
903503	10,0	360	17,4	90	TX50 ●	50
903504	10,0	380	17,4	90	TX50 ●	50
903505	10,0	400	17,4	90	TX50 ●	50



Simple screw connection of a post and beam construction using our Paneltwistec countersunk head.

Panelwistec

Washer head screw, screw tip with self-clearing groove, steel yellow galvanized



NKL 1 – 2

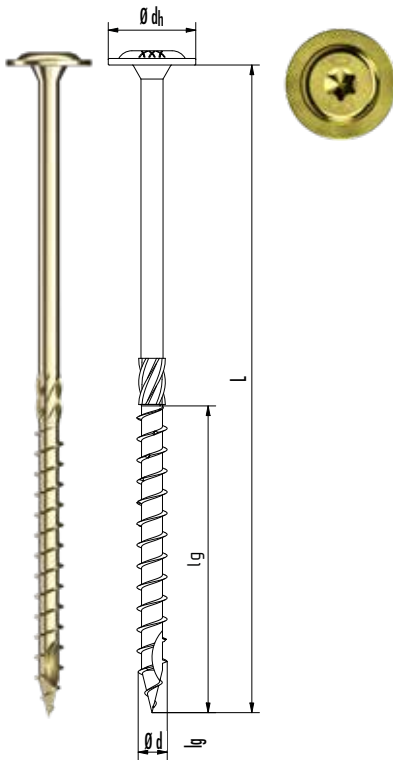

Art. no.	Ø d [mm]	L [mm]	Ø dh [mm]	lg [mm]	Drive	PU
G903204	8,0	80	22,0	48	TX40 ●	50
G903205	8,0	100	22,0	60	TX40 ●	50
G903466	8,0	120	22,0	80	TX40 ●	50
G903467	8,0	140	22,0	80	TX40 ●	50
G903468	8,0	160	22,0	80	TX40 ●	50
G903469	8,0	180	22,0	80	TX40 ●	50
G903470	8,0	200	22,0	80	TX40 ●	50
G903471	8,0	220	22,0	80	TX40 ●	50
G903472	8,0	240	22,0	80	TX40 ●	50
G903473	8,0	260	22,0	80	TX40 ●	50
G903474	8,0	280	22,0	80	TX40 ●	50
G903475	8,0	300	22,0	80	TX40 ●	50
G903476	8,0	320	22,0	80	TX40 ●	50
G903477	8,0	340	22,0	80	TX40 ●	50
G903478	8,0	360	22,0	80	TX40 ●	50
G904625	8,0	380	22,0	80	TX40 ●	50
G904626	8,0	400	22,0	80	TX40 ●	50



Simple screw connection of a post and beam construction using our Panelwistec washer head screw.

# PANELTWISTEC, PANELTWISTEC AG

Hardened stainless steel

Panelwistec Hardened Stainless Steel								
Geometric properties					Mechanical properties			
Nominal Ø [mm]	Root Øi [mm]	Shaft Øs [mm]	Head <sup>a)</sup> Øh [mm]	Thread length [mm]	f <sub>tens,k</sub> [kN]	f <sub>ax,k</sub> [MPa]	f <sub>head,k</sub> [MPa]	M <sub>y,k</sub> [Nm]
4	2,5	2,8	8,0	16 - 48	5,0	12,9	12,0	3,3
4,5	2,7	3,0	9,0	16 - 60	6,4	12,5	12,0	4,5
5	3,3	4,6	10,0	25 - 70	7,9	12,1	12,0	5,9
6	4,0	4,3	12,0 / 14,0	36 - 70	11,0	11,4	12,0	9,5
8	5,3	5,7	18,0	48 - 80	20,0	11,1	12,0	20,0

<sup>a)</sup> Countersunk head / Washer head. Ø8 mm is only available as a washer head.

## Panelwistec

Countersunk head, screw tip with self-clearing groove, hardened stainless steel

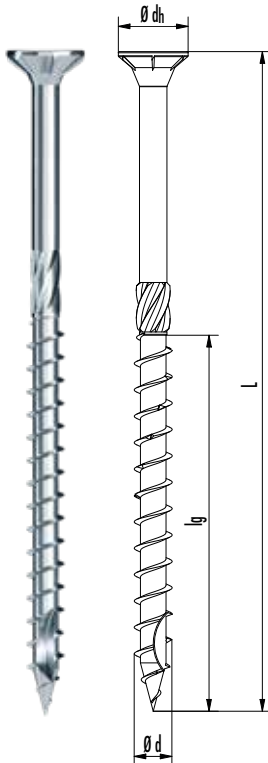

Art. no.	Ø d [mm]	L [mm]	Ø dh [mm]	lg [mm]	Drive	PU
904494	4,0	30	7	21	TX20	500
904495	4,0	35	7	21	TX20	500
904474	4,0	40	7	24	TX20	500
904475	4,0	45	7	27	TX20	500
904476	4,0	50	7	30	TX20	500
904477	4,0	60	7	36	TX20	500
904478	4,5	45	9	27	TX20	200
904479	4,5	50	9	30	TX20	200
904480	4,5	60	9	36	TX20	200
904481	4,5	70	9	42	TX20	200
100981	4,5	80	9	48	TX20	200
904482	5,0	50	10	30	TX25	200
904483	5,0	60	10	36	TX25	200
904484	5,0	70	10	42	TX25	200
904485	5,0	80	10	48	TX25	200
904487	5,0	90	10	54	TX25	100
904011	5,0	100	10	60	TX25	100
904012	6,0	60	12	36	TX30	100
904013	6,0	70	12	42	TX30	100
904014	6,0	80	12	48	TX30	100
904015	6,0	90	12	54	TX30	100
904016	6,0	100	12	60	TX30	100
904017	6,0	120	12	70	TX30	100
904018	6,0	140	12	70	TX30	100
904019	6,0	160	12	70	TX30	100

### Panelwistec

Washer head screw, screw tip with self-clearing groove, hardened stainless steel

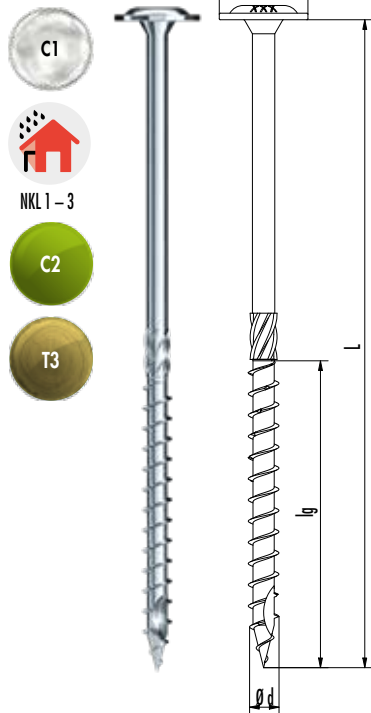

Art. no.	Ø d [mm]	L [mm]	Ø dh [mm]	lg [mm]	Drive	PU
945278	8,0	80	16	48	TX40 ●	50
945270	8,0	100	16	60	TX40 ●	50
945271	8,0	120	16	80	TX40 ●	50
945272	8,0	140	16	80	TX40 ●	50
945364	8,0	160	16	80	TX40 ●	50
945365	8,0	180	16	80	TX40 ●	50
945366	8,0	200	16	80	TX40 ●	50
945367	8,0	220	16	80	TX40 ●	50
945368	8,0	240	16	80	TX40 ●	50
945369	8,0	260	16	80	TX40 ●	50
945370	8,0	280	16	80	TX40 ●	50
945371	8,0	300	16	80	TX40 ●	50
945372	8,0	320	16	80	TX40 ●	50
945373	8,0	340	16	80	TX40 ●	50
945374	8,0	360	16	80	TX40 ●	50
945375	8,0	380	16	80	TX40 ●	50
945376	8,0	400	16	80	TX40 ●	50

### Panelwistec AG

Washer head screw, AG screw tip hardened stainless steel

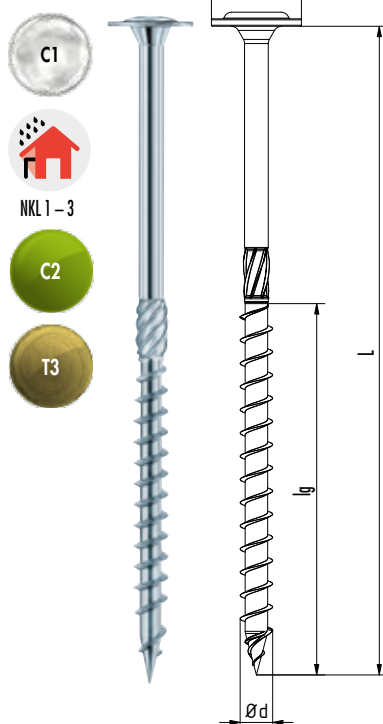

Art. no.	Ø d [mm]	L [mm]	Ø dh [mm]	lg [mm]	Drive	PU
975771	6,0	40	14,0	24	TX30 ●	100
975772	6,0	60	14,0	36	TX30 ●	100
975773	6,0	80	14,0	48	TX30 ●	100
975774	6,0	100	14,0	60	TX30 ●	100
975775	6,0	120	14,0	70	TX30 ●	100
975776	6,0	140	14,0	70	TX30 ●	100
975777	6,0	160	14,0	70	TX30 ●	100

# PANELTWISTEC A4

Stainless steel A4

## Paneltwistec

Countersunk head, stainless steel A4

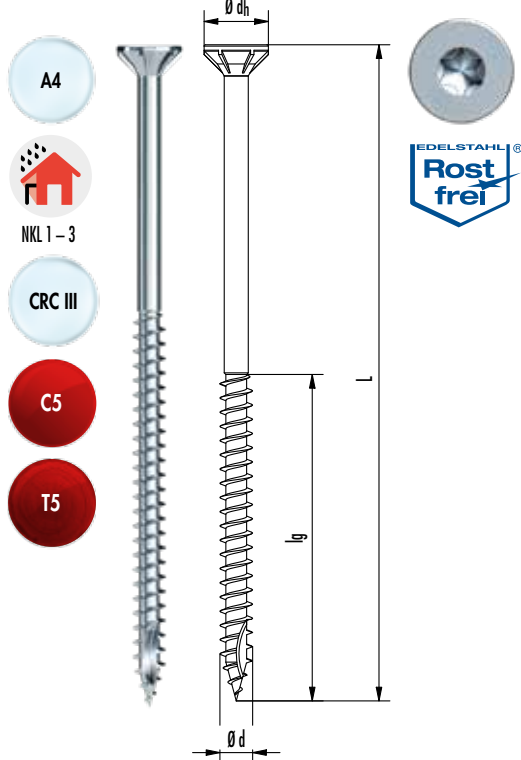

- A4
- NKL 1 – 3
- CRC III
- C5
- T5



Art. no.	Ø d [mm]	L [mm]	Ø dh [mm]	lg [mm]	Drive	PU
901476	4,0	25	7,75	15	TX20 ●	500
111442	4,0	35	7,75	21	TX20 ●	500
903202	4,0	40	7,75	24	TX20 ●	500
111443	4,0	45	7,75	27	TX20 ●	500
901109	4,0	55	7,75	33	TX20 ●	500
111444	4,0	60	7,75	36	TX20 ●	500
111445	4,0	70	7,75	42	TX20 ●	200
111446	4,0	80	7,75	48	TX20 ●	200
111447	4,5	45	8,75	27	TX25 ●	200
111448	4,5	60	8,75	36	TX25 ●	200
111449	4,5	70	8,75	42	TX25 ●	200
111450	4,5	80	8,75	48	TX25 ●	200
903990	5,0	40	9,75	24	TX25 ●	200
111451	5,0	50	9,75	30	TX25 ●	200
111452	5,0	60	9,75	36	TX25 ●	200
111453	5,0	70	9,75	42	TX25 ●	200
111454	5,0	80	9,75	48	TX25 ●	200
903580	5,0	100	9,75	60	TX25 ●	200
111459	6,0	60	11,75	36	TX30 ●	100
944885	6,0	70	11,75	42	TX30 ●	100
111460	6,0	80	11,75	48	TX30 ●	100
111458	6,0	100	11,75	60	TX30 ●	100
901478	6,0	120	11,75	60	TX30 ●	100

## Paneltwistec A4

Countersunk head, stainless steel A4

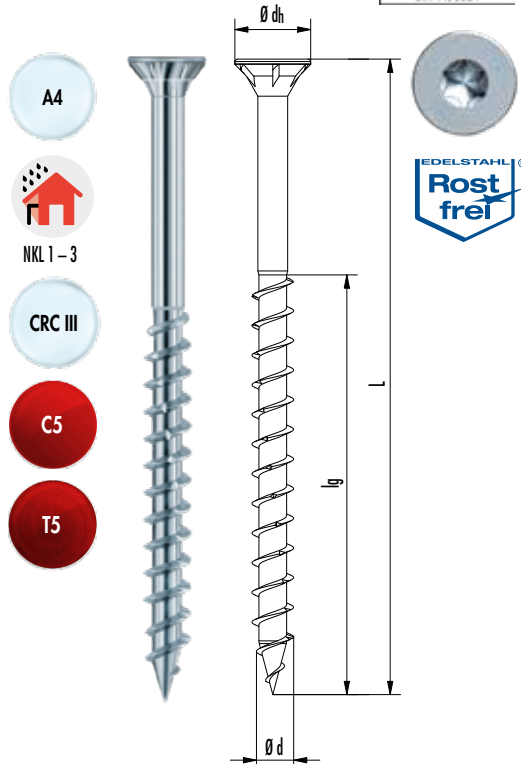

- A4
- NKL 1 – 3
- CRC III
- C5
- T5



Art. no.	Ø d [mm]	L [mm]	Ø dh [mm]	lg [mm]	Drive	PU
903280	8,0	80	14,50	48	TX40 ●	50
903281	8,0	100	14,50	60	TX40 ●	50
903282	8,0	120	14,50	80	TX40 ●	50
903283	8,0	140	14,50	80	TX40 ●	50
903284	8,0	160	14,50	80	TX40 ●	50
903285	8,0	180	14,50	80	TX40 ●	50
903286	8,0	200	14,50	80	TX40 ●	50
903287	8,0	220	14,50	80	TX40 ●	50
903288	8,0	240	14,50	80	TX40 ●	50
903289	8,0	260	14,50	80	TX40 ●	50
903290	8,0	280	14,50	80	TX40 ●	50
903291	8,0	300	14,50	80	TX40 ●	50
903292	8,0	320	14,50	80	TX40 ●	50
903293	8,0	340	14,50	80	TX40 ●	50
903294	8,0	360	14,50	80	TX40 ●	50
903295	8,0	380	14,50	80	TX40 ●	50
903296	8,0	400	14,50	80	TX40 ●	50

### Panelwistec A4

Ornamental head, stainless steel A4



- 
- 
- 
- 
- 

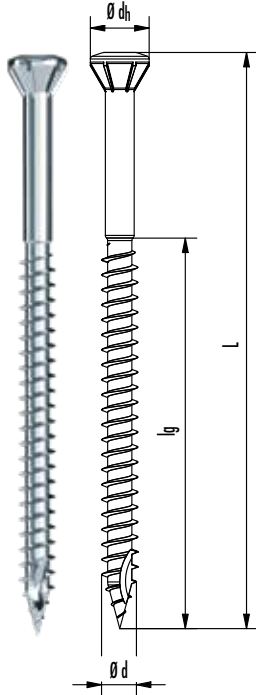

Art. no.	Ø d [mm]	L [mm]	Ø dh [mm]	lg [mm]	Drive	PU
901479	3,2	25	5,10	17,5	TX10 ◯	1000
903038	3,2	30	5,10	21	TX10 ◯	1000
901480	3,2	35	5,10	19	TX10 ◯	1000
901481	3,2	40	5,10	24	TX10 ◯	1000
903104	3,2	50	5,10	34	TX10 ◯	1000

### Panelwistec A4

Washer head screw, stainless steel A4



- 
- 
- 
- 
- 

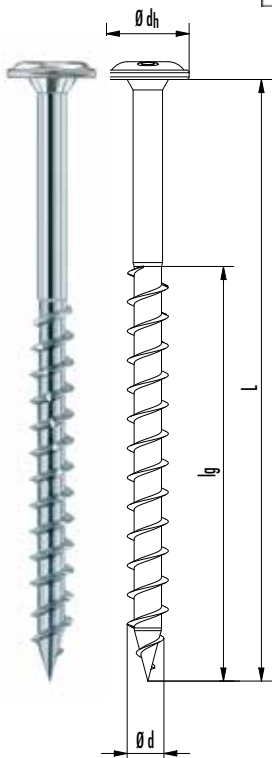

Art. no.	Ø d [mm]	L [mm]	Ø dh [mm]	lg [mm]	Drive	PU
903260	8,0	80	16	48	TX40 ●	50
903261	8,0	100	16	60	TX40 ●	50
903262	8,0	120	16	80	TX40 ●	50
903263	8,0	140	16	80	TX40 ●	50
903264	8,0	160	16	80	TX40 ●	50
903265	8,0	180	16	80	TX40 ●	50
903266	8,0	200	16	80	TX40 ●	50
903267	8,0	220	16	80	TX40 ●	50
903268	8,0	240	16	80	TX40 ●	50
903269	8,0	260	16	80	TX40 ●	50
903270	8,0	280	16	80	TX40 ●	50
903271	8,0	300	16	80	TX40 ●	50
903272	8,0	320	16	80	TX40 ●	50
903273	8,0	340	16	80	TX40 ●	50
903274	8,0	360	16	80	TX40 ●	50
903275	8,0	380	16	80	TX40 ●	50
903276	8,0	400	16	80	TX40 ●	50

# PANELTWISTEC A2

Stainless steel A2

## Panelwistec Stainless Steel A2

Geometric properties					Mechanical properties			
Nominal $\varnothing$ [mm]	Root $\varnothing_i$ [mm]	Shaft $\varnothing_s$ [mm]	Head <sup>a)</sup> $\varnothing_h$ [mm]	Thread length [mm]	$f_{tens,k}$ [kN]	$f_{ax,k}$ [MPa]	$f_{head,k}$ [MPa]	$M_{y,k}$ [Nm]
3,2	-	-	5,1	17,5 – 34	2,4	13,3	8,2	0,8
4	2,5	2,8	8,0	15 – 48	2,8	12,9	12,0	1,7
4,5	2,7	3,0	9,0	27 – 48	3,5	12,5	12,0	2,4
5	3,3	3,6	10,0	30 – 60	4,3	12,1	12,0	3,1
6	4,0	4,3	12,0	36 – 70	6,2	11,4	12,0	5,0
8	5,3	5,7	14,5 / 16,0	48 – 80	11,0	11,1	12,0	10,7

<sup>a)</sup> Countersunk head / Washer head.  $\varnothing 6$ mm is only available as a countersunk head with A4 stainless steel.

## Panelwistec A2

Countersunk head, stainless steel A2

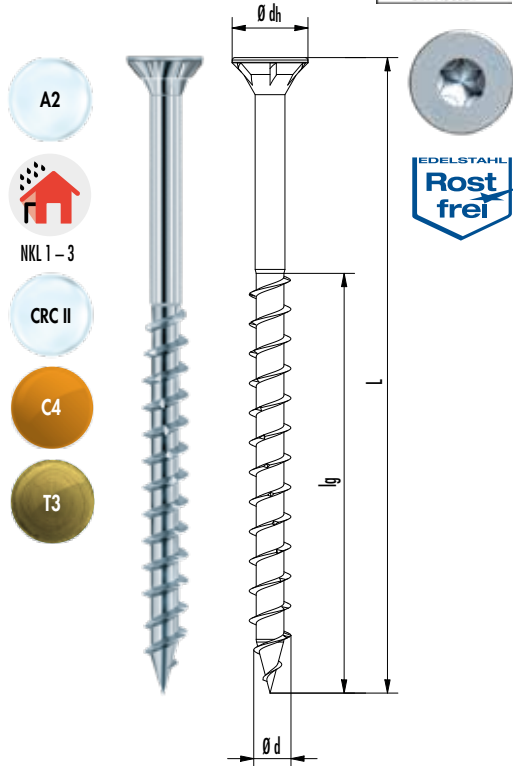

Art. no.	$\varnothing d$ [mm]	L [mm]	$\varnothing dh$ [mm]	$l_g$ [mm]	Drive	PU
903230	8,0	80	14,5	48	TX40	50
903231	8,0	100	14,5	60	TX40	50
903232	8,0	120	14,5	80	TX40	50
903233	8,0	140	14,5	80	TX40	50
903234	8,0	160	14,5	80	TX40	50
903235	8,0	180	14,5	80	TX40	50
903236	8,0	200	14,5	80	TX40	50
903237	8,0	220	14,5	80	TX40	50
903238	8,0	240	14,5	80	TX40	50
903239	8,0	260	14,5	80	TX40	50
903240	8,0	280	14,5	80	TX40	50
903241	8,0	300	14,5	80	TX40	50
903242	8,0	320	14,5	80	TX40	50
903243	8,0	340	14,5	80	TX40	50
903244	8,0	360	14,5	80	TX40	50
903245	8,0	380	14,5	80	TX40	50
903246	8,0	400	14,5	80	TX40	50

Paneltwistec A2

Washer head screw, stainless steel A2

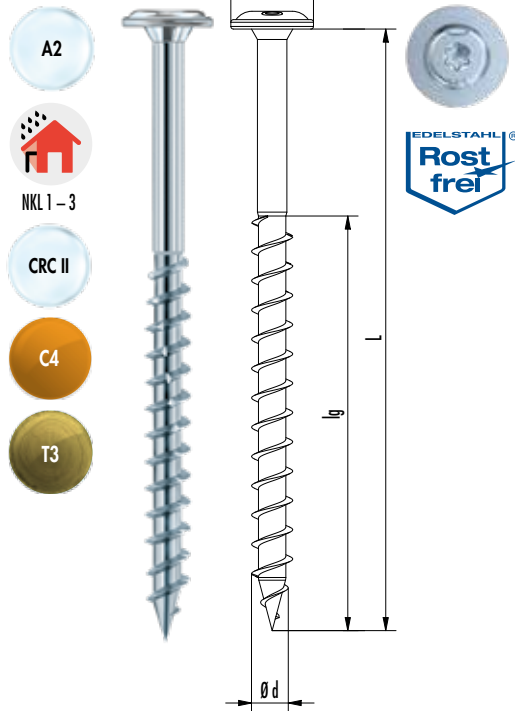

Art. no.	Ø d [mm]	L [mm]	Ø dh [mm]	lg [mm]	Drive	PU
946266 <sup>a)</sup>	3,0	25	9	18	TX10 ◯	1000
946267 <sup>a)</sup>	3,0	30	9	18	TX10 ◯	1000
946268 <sup>a)</sup>	3,0	35	9	24	TX10 ◯	1000
946269 <sup>a)</sup>	3,0	40	9	24	TX10 ◯	1000
946270 <sup>a)</sup>	3,0	45	9	30	TX10 ◯	1000
946271 <sup>a)</sup>	3,0	50	9	30	TX10 ◯	1000
946272 <sup>b)</sup>	4,0	30	12	18	TX20 ●	1000
946273 <sup>b)</sup>	4,0	40	12	24	TX20 ●	1000
946274 <sup>b)</sup>	4,0	50	12	30	TX20 ●	500
946275 <sup>b)</sup>	4,0	60	12	36	TX20 ●	500
946276 <sup>b)</sup>	4,0	70	12	42	TX20 ●	200
946277 <sup>b)</sup>	4,5	40	13	24	TX20 ●	500
946278 <sup>b)</sup>	4,5	50	13	30	TX20 ●	500
946279 <sup>b)</sup>	4,5	60	13	36	TX20 ●	200
946280 <sup>b)</sup>	4,5	70	13	42	TX20 ●	200
946281 <sup>b)</sup>	4,5	80	13	48	TX20 ●	200
946282 <sup>b)</sup>	5,0	40	14	24	TX25 ●	200
946283 <sup>b)</sup>	5,0	50	14	30	TX25 ●	200
946284 <sup>b)</sup>	5,0	60	14	36	TX25 ●	200
946285 <sup>b)</sup>	5,0	70	14	42	TX25 ●	200
946286 <sup>b)</sup>	5,0	80	14	48	TX25 ●	200
946287 <sup>b)</sup>	5,0	100	14	60	TX25 ●	200
946288 <sup>b)</sup>	5,0	120	14	70	TX25 ●	200
946289 <sup>b)</sup>	6,0	60	15	36	TX30 ●	200
946290 <sup>b)</sup>	6,0	80	15	48	TX30 ●	200
946291 <sup>b)</sup>	6,0	100	15	70	TX30 ●	100
946292 <sup>b)</sup>	6,0	120	15	70	TX30 ●	100
946293 <sup>b)</sup>	6,0	140	15	70	TX30 ●	100
946294 <sup>b)</sup>	6,0	160	15	70	TX30 ●	100
946295 <sup>b)</sup>	6,0	180	15	70	TX30 ●	100
946296 <sup>b)</sup>	6,0	200	15	70	TX30 ●	100
946291 <sup>b)</sup>	6,0	100	15	70	TX30 ●	100
946292 <sup>b)</sup>	6,0	120	15	70	TX30 ●	100
946293 <sup>b)</sup>	6,0	140	15	70	TX30 ●	100
946294 <sup>b)</sup>	6,0	160	15	70	TX30 ●	100
946295 <sup>b)</sup>	6,0	180	15	70	TX30 ●	100
946296 <sup>b)</sup>	6,0	200	15	70	TX30 ●	100
903211	8,0	80	16	48	TX40 ●	50
903212	8,0	100	16	60	TX40 ●	50
903213	8,0	120	16	80	TX40 ●	50
903214	8,0	140	16	80	TX40 ●	50
903215	8,0	160	16	80	TX40 ●	50
903216	8,0	180	16	80	TX40 ●	50
903217	8,0	200	16	80	TX40 ●	50
903218	8,0	220	16	80	TX40 ●	50
903219	8,0	240	16	80	TX40 ●	50
903220	8,0	260	16	80	TX40 ●	50
903221	8,0	280	16	80	TX40 ●	50
903222	8,0	300	16	80	TX40 ●	50
903223	8,0	320	16	80	TX40 ●	50
903224	8,0	340	16	80	TX40 ●	50
903225	8,0	360	16	80	TX40 ●	50
903226	8,0	380	16	80	TX40 ●	50
903227	8,0	400	16	80	TX40 ●	50

<sup>a)</sup> No European Technical Assessment (ETA) is currently available for this product.

<sup>b)</sup> European Technical Assessment (ETA) has been applied for.

# PANELTWISTEC 1000

Steel specially coated

The Paneltwistec 1000 is a fastener made from specially coated and hardened carbon steel, designed for use in load-bearing timber structures to connect components made of solid coniferous timber, glued laminated timber, laminated veneer lumber, or similar engineered wood products. The screw has a **self-clearing groove** at the screw tip and **milling ribs** above the thread. The screw is available in "countersunk head" and "washer head" versions. The screw's special geometry ensures a **reduced splitting effect during installation**. Thanks to the special coating, **the screw-in resistance is also reduced**, due to less friction between the body of the screw and the wood.



Paneltwistec 1000 Carbon Steel

Geometric properties					Mechanical properties			
Nominal Ø [mm]	Root Ø <sub>i</sub> [mm]	Shaft Ø <sub>s</sub> [mm]	Head <sup>a)</sup> Ø <sub>h</sub> [mm]	Thread length [mm]	f <sub>tens,k</sub> [kN]	f <sub>ax,k</sub> [MPa]	f <sub>head,k</sub> [MPa]	M <sub>y,k</sub> [Nm]
3	1,9	2,1	5,6	12 – 25	2,6	11,8	12,0	1,2
3,5	2,1	2,3	7,0	12 – 27	3,8	13,3	12,0	2,3
4	2,5	2,8	8,0/10,0	16 – 48	5,0	12,9	12,0	3,3
4,5	2,7	3,0	9,0/11,0	16 – 60	6,4	12,5	12,0	4,5
5	3,3	4,6	10,0/12,0	25 – 70	7,9	12,1	12,0	5,9
6	4,0	4,3	12,0/14,0	24 – 70	11,0	11,4	12,0	9,5
8	5,3	5,7	22,0	48 – 80	20,0	11,1	12,0	20,0
10	6,3	6,9	25,0	36 – 100	28,0	10,8	12,0	35,8

<sup>a)</sup> Countersunk head / Washer head. Ø6 mm is only available as a countersunk head with A4 stainless steel.



**Paneltwistec 1000**

Countersunk head, screw tip with self-clearing groove, steel specially coated



NKL 1 - 2

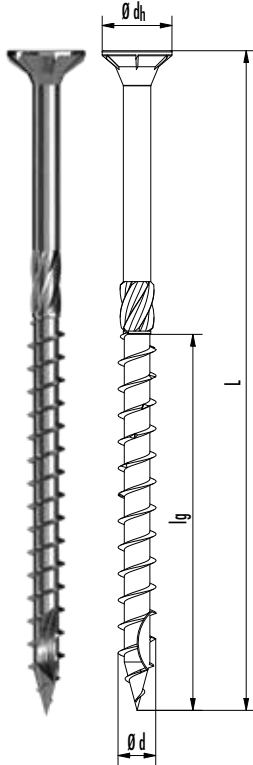

Art. no.	$\varnothing d$ [mm]	L [mm]	$\varnothing d_h$ [mm]	lg [mm]	Drive	PU
R945034	3,0	12	5,6	Full thread	TX10 ◊	1000
R945035	3,0	16	5,6	Full thread	TX10 ◊	1000
R903038	3,0	20	5,6	Full thread	TX10 ◊	1000
R903039	3,0	25	5,6	Full thread	TX10 ◊	1000
R903040	3,0	30	5,6	18	TX10 ◊	1000
R903041	3,0	35	5,6	21	TX10 ◊	1000
R903042	3,0	40	5,6	24	TX10 ◊	1000
R945036	3,5	12	7,0	Full thread	TX20 ●	1000
R945037	3,5	16	7,0	Full thread	TX20 ●	1000
R903043	3,5	20	7,0	Full thread	TX20 ●	1000
R903044	3,5	25	7,0	Full thread	TX20 ●	1000
R903045	3,5	30	7,0	18	TX20 ●	1000
R903046	3,5	35	7,0	21	TX20 ●	1000
R903047	3,5	40	7,0	24	TX20 ●	1000
R903048	3,5	50	7,0	27	TX20 ●	500
R945038	4,0	16	8,0	Full thread	TX20 ●	1000
R903001	4,0	20	8,0	Full thread	TX20 ●	1000
R903002	4,0	25	8,0	Full thread	TX20 ●	1000
R903003	4,0	30	8,0	18	TX20 ●	1000
R903049	4,0	35	8,0	21	TX20 ●	1000
R903004	4,0	40	8,0	24	TX20 ●	1000
R902089	4,0	45	8,0	27	TX20 ●	500
R903005	4,0	50	8,0	30	TX20 ●	500
R903006	4,0	60	8,0	36	TX20 ●	200
R903007	4,0	70	8,0	42	TX20 ●	200
R903008	4,0	80	8,0	48	TX20 ●	200
R945039	4,5	16	9,0	Full thread	TX20 ●	1000
R903050	4,5	25	9,0	Full thread	TX20 ●	500
R903051	4,5	30	9,0	18	TX20 ●	500
R903052	4,5	35	9,0	21	TX20 ●	500
R903009	4,5	40	9,0	24	TX20 ●	500
R903010	4,5	50	9,0	30	TX20 ●	500
R903011	4,5	60	9,0	36	TX20 ●	200
R903012	4,5	70	9,0	42	TX20 ●	200
R903013	4,5	80	9,0	48	TX20 ●	200
R903468	4,5	90	9,0	54	TX20 ●	200
R903063	4,5	100	9,0	60	TX20 ●	200
R903053	5,0	25	10,0	Full thread	TX20 ●	500
R903054	5,0	30	10,0	20	TX20 ●	500
R903055	5,0	35	10,0	21	TX20 ●	500
R903014	5,0	40	10,0	24	TX20 ●	200
R903579	5,0	45	10,0	27	TX20 ●	200
R903015	5,0	50	10,0	30	TX20 ●	200
R903016	5,0	60	10,0	36	TX20 ●	200
R903017	5,0	70	10,0	42	TX20 ●	200
R903018	5,0	80	10,0	48	TX20 ●	200
R903578	5,0	90	10,0	54	TX20 ●	200
R903019	5,0	100	10,0	60	TX20 ●	200
R903020	5,0	120	10,0	70	TX20 ●	200

other sizes on the next page

Art. no.	Ø d [mm]	L [mm]	Ø dh [mm]	lg [mm]	Drive	PU
R903581	6,0	40	12,0	24	TX30 ●	200
R903582	6,0	50	12,0	30	TX30 ●	200
R903021	6,0	60	12,0	36	TX30 ●	200
R903022	6,0	70	12,0	42	TX30 ●	200
R903023	6,0	80	12,0	48	TX30 ●	200
R903163	6,0	90	12,0	54	TX30 ●	100
R903024	6,0	100	12,0	60	TX30 ●	100
R903025	6,0	120	12,0	70	TX30 ●	100
R903026	6,0	130	12,0	70	TX30 ●	100
R903027	6,0	140	12,0	70	TX30 ●	100
R903029	6,0	160	12,0	70	TX30 ●	100
R903031	6,0	180	12,0	70	TX30 ●	100
R903032	6,0	200	12,0	70	TX30 ●	100
R903033	6,0	220	12,0	70	TX30 ●	100
R903034	6,0	240	12,0	70	TX30 ●	100
R903035	6,0	260	12,0	70	TX30 ●	100
R903036	6,0	280	12,0	70	TX30 ●	100
R903037	6,0	300	12,0	70	TX30 ●	100

## Paneltwistec 1000

Washer head screw, steel specially coated



NKL 1 – 2

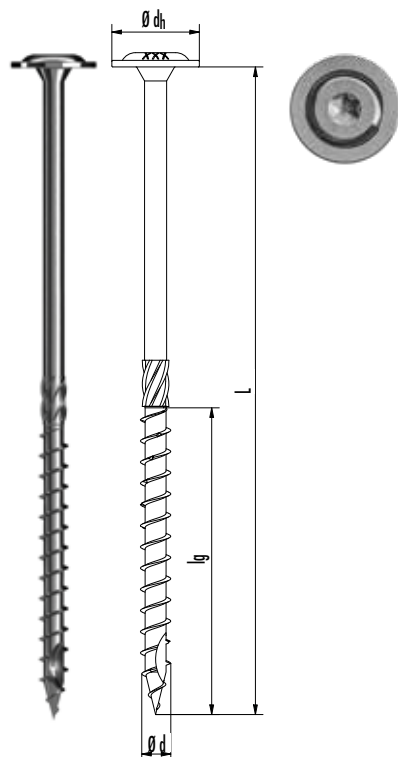

Art. no.	Ø d [mm]	L [mm]	Ø dh [mm]	lg [mm]	Drive	PU
R901357	6,0	100	14,0	60	TX30 ●	100
R901359	6,0	120	14,0	70	TX30 ●	100
R901361	6,0	140	14,0	70	TX30 ●	100
R901364	6,0	180	14,0	70	TX30 ●	100
R901365	6,0	200	14,0	70	TX30 ●	100
R903060	8,0	80	22,0	48	TX40 ●	50
R903062	8,0	100	22,0	54	TX40 ●	50
R903064	8,0	120	22,0	60	TX40 ●	50
R903066	8,0	140	22,0	80	TX40 ●	50
R903067	8,0	160	22,0	80	TX40 ●	50
R903470	8,0	180	22,0	80	TX40 ●	50
R903069	8,0	200	22,0	80	TX40 ●	50
R903472	8,0	220	22,0	80	TX40 ●	50
R903071	8,0	240	22,0	80	TX40 ●	50
R903072	8,0	260	22,0	80	TX40 ●	50
R903073	8,0	280	22,0	80	TX40 ●	50
R903074	8,0	300	22,0	80	TX40 ●	50
R903475	8,0	360	22,0	80	TX40 ●	50
R904625	8,0	380	22,0	80	TX40 ●	50
R903476	8,0	400	22,0	80	TX40 ●	50
R903077	10,0	60	25,0	36	TX40 ●	50
R903079	10,0	80	25,0	50	TX40 ●	50
R903081	10,0	100	25,0	60	TX40 ●	50
R903083	10,0	120	25,0	70	TX40 ●	50
R903085	10,0	160	25,0	90	TX40 ●	50
R903086	10,0	180	25,0	100	TX40 ●	50
R903087	10,0	200	25,0	100	TX40 ●	50
R903088	10,0	220	25,0	100	TX40 ●	50
R903089	10,0	240	25,0	100	TX40 ●	50

## PANELTWISTEC TK AG STRONGHEAD

For the application of press-laminated structural timber components

Paneltwistec wood construction screws can be installed **in CLT or laminated timber without pre-Drill tipping**. Paneltwistec has a **special AG screw tip and milling ribs** above the thread, ensuring it grips quickly and has a reduced splitting effect when screwing in. What's more, the thread not only speeds up the installation process but also **reduces the screw-in torque**. The washer head offers a **high head pull-through resistance** and ensures sufficient **pressure between the two surfaces to be connected**, which is very effective for adhesive bonding. If the press-gluing is carried out properly during the curing of the adhesives, it is possible to produce composite timber components. Furthermore, ribbed panel applications can be performed with Paneltwistec stronghead screws.

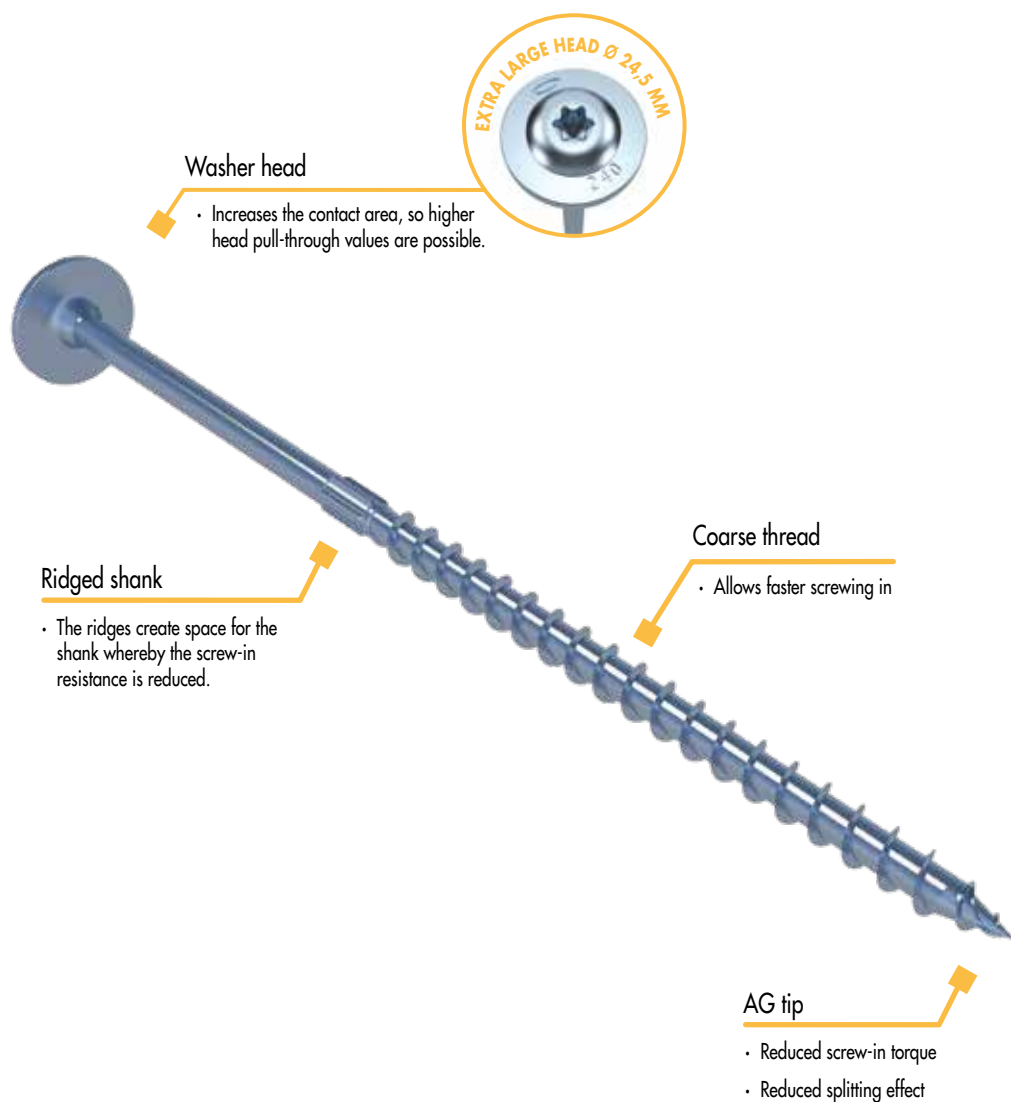

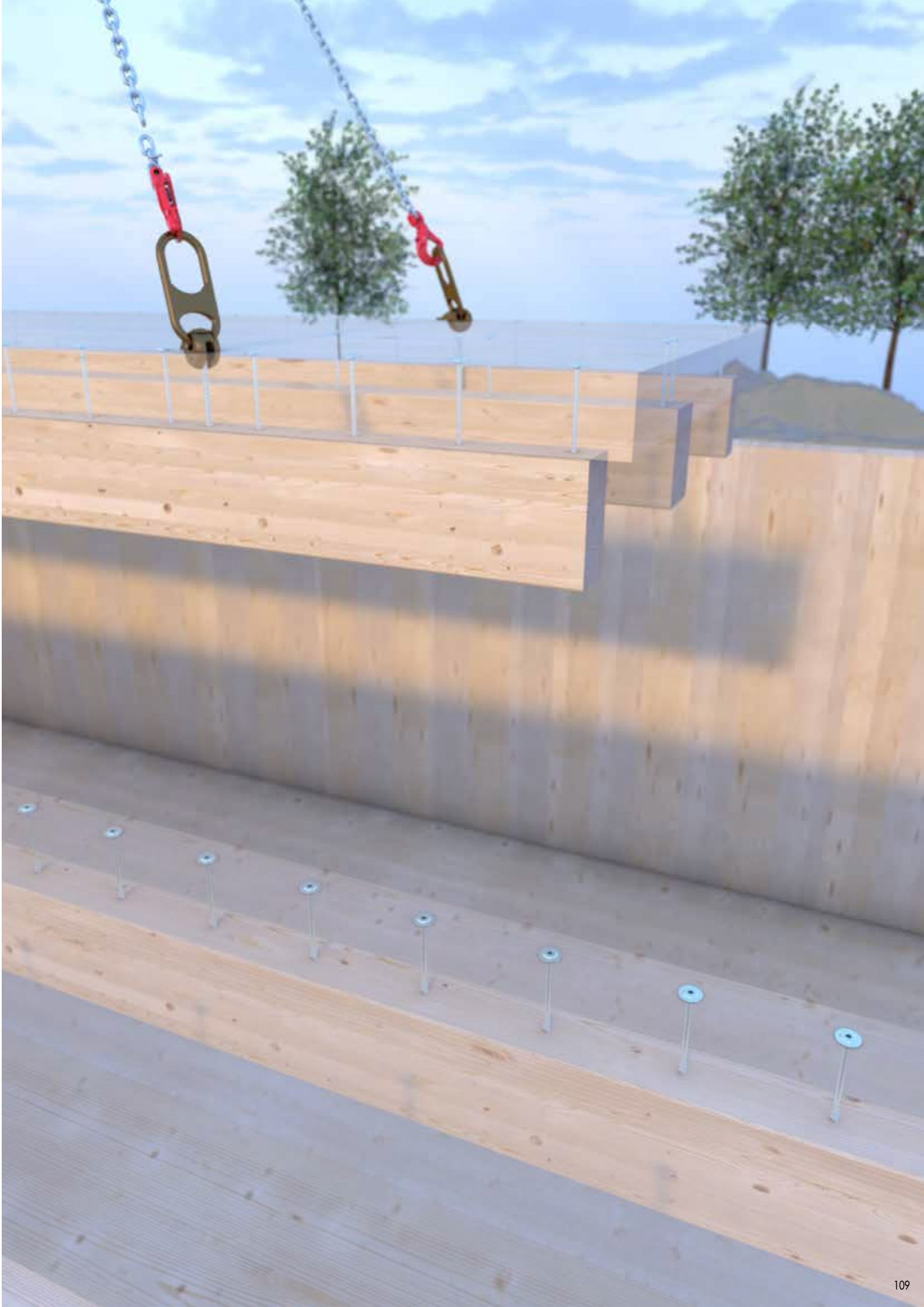

**Panelwistec TK AG Strong Head**

Geometric properties					Mechanical properties			
Nominal Ø [mm]	Root Øi [mm]	Shaft Øs [mm]	Head <sup>a)</sup> Øh [mm]	Thread length [mm]	f <sub>tens,k</sub> [kN]	f <sub>ax,k</sub> [MPa]	f <sub>head,k</sub> [MPa]	M <sub>y,k</sub> [Nm]
8	5,3	5,7	24,5	120	20,0	11,1	12,0	20,0

<sup>a)</sup> Countersunk head / Washer head. Ø6 mm is only available as a countersunk head with A4 stainless steel.

**Panelwistec TK AG Stronghead**

Washer head screw, blue galvanised



NKL 1 – 2

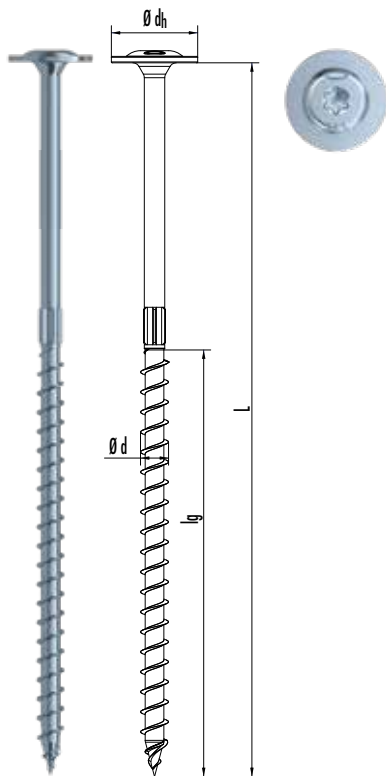

Art. no.	Ø d [mm]	L [mm]	Ø dh [mm]	lg [mm]	Drive	PU
903170	8,0	200	24,5	120	TX40 ●	50
903171	8,0	220	24,5	120	TX40 ●	50
903172	8,0	240	24,5	120	TX40 ●	50
903173	8,0	260	24,5	120	TX40 ●	50
903174	8,0	280	24,5	120	TX40 ●	50
903175	8,0	300	24,5	120	TX40 ●	50
903176	8,0	320	24,5	120	TX40 ●	50
903177	8,0	340	24,5	120	TX40 ●	50
903178	8,0	360	24,5	120	TX40 ●	50
903179	8,0	380	24,5	120	TX40 ●	50
903180	8,0	400	24,5	120	TX40 ●	50



*Bonding pressure distribution in the screw press bonding of rib panel elements*

# SAWTEC

Wood construction screw with a flush installation

The SawTec is a wood construction screw **with a special screw tip and saw teeth below the head**. The screw has a **double-stage cylinder head**. The special geometry of the screw tip **reduces the screwing torque** and also leads to a **lower splitting effect** when screwing in.

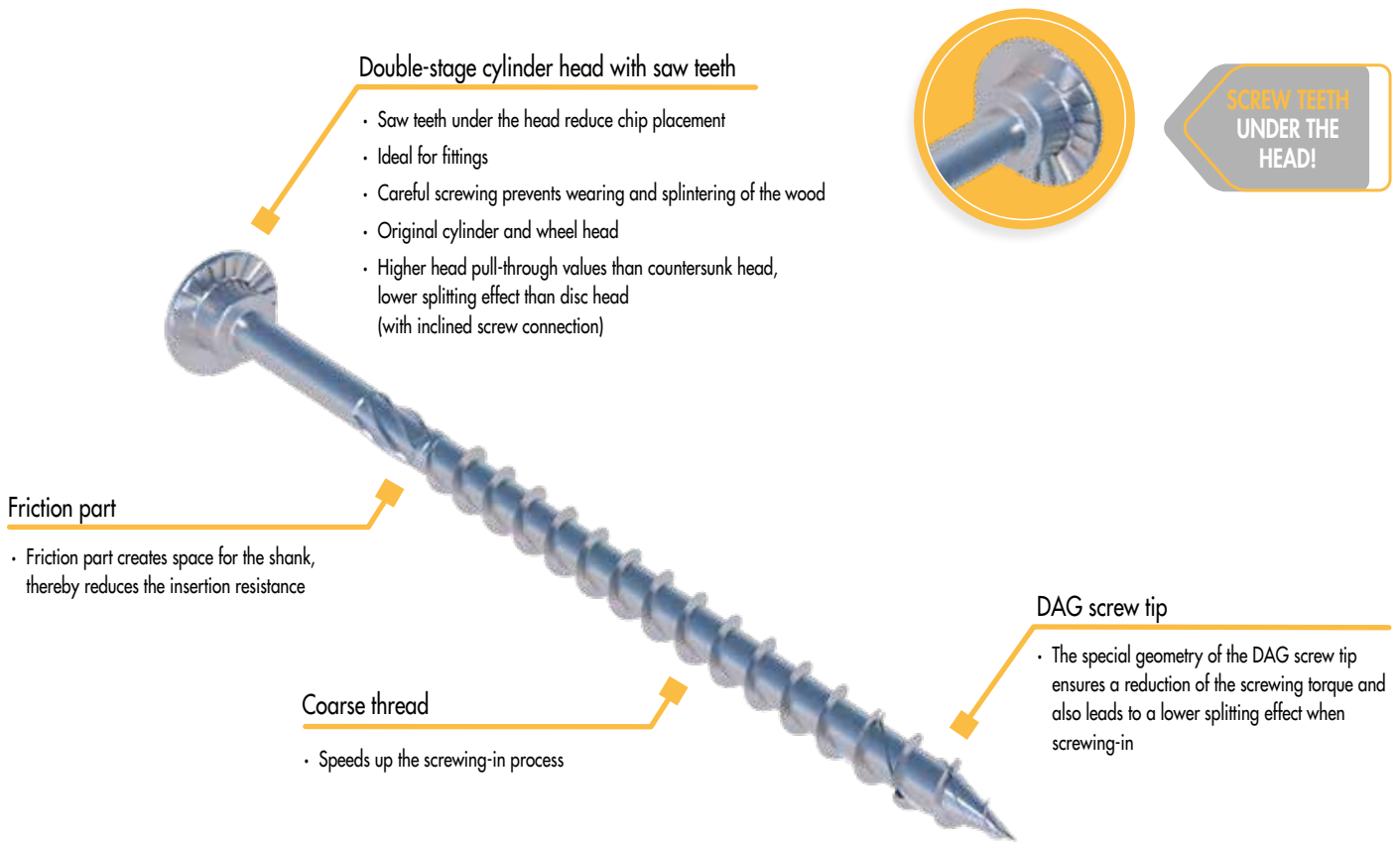

## SawTec Carbon Steel

Geometric properties					Mechanical properties			
Nominal Ø [mm]	Root Ø <sub>i</sub> [mm]	Shaft Ø <sub>s</sub> [mm]	Head <sup>a)</sup> Ø <sub>h</sub> [mm]	Thread length [mm]	f <sub>tens,k</sub> [kN]	f <sub>ax,k</sub> [MPa]	f <sub>head,k</sub> [MPa]	M <sub>y,k</sub> [Nm]
5	3,3	3,6	10,5	24 - 60	7,9	12,1	10,0	5,9
6	4,0	4,4	13,0	24 - 70	11,0	11,4	10,0	9,5
8	5,3	5,8	18,0	32 - 100	20,0	11,1	10,0	20,0
10	6,3	7,1	22,0	40 - 100	28,0	10,8	10,0	35,8

## SawTec

Cylinder head, blue galvanised

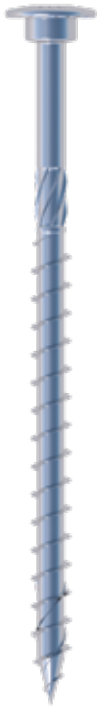

### ADVANTAGES

- Faster and easier screwing-in due to the DAG tip
- The DAG tip reduces the screw-in torque
- Reduced splitting effect
- Screws do not hit one another when screwed in using the TX drive

### APPLICATION INFORMATION

Can be used in service classes 1 and 2 according to DIN EN 1995 – Eurocode 5



A downstand beam is fastened to the notched CLT wall by means of the SawTec partially threaded screw.

Art. no.	Ø d [mm]	L [mm]	Ø dh [mm]	lg [mm]	Drive	PU
954115	5,0	40	10,5	24	TX25 •	200
954117	5,0	50	10,5	30	TX25 •	200
954118	5,0	60	10,5	36	TX25 •	200
954119	5,0	70	10,5	42	TX25 •	200
954120	5,0	80	10,5	48	TX25 •	200
954121	5,0	90	10,5	54	TX25 •	200
954122	5,0	100	10,5	60	TX25 •	200
954124	5,0	120	10,5	60	TX25 •	200
954128	6,0	60	13,0	36	TX30 •	100
954129	6,0	70	13,0	42	TX30 •	100
954130	6,0	80	13,0	48	TX30 •	100
954131	6,0	100	13,0	60	TX30 •	100
954133	6,0	120	13,0	60	TX30 •	100
954135	6,0	140	13,0	70	TX30 •	100
954137	6,0	160	13,0	70	TX30 •	100
954138	6,0	180	13,0	70	TX30 •	100
954139	6,0	200	13,0	70	TX30 •	100
954140	6,0	220	13,0	70	TX30 •	100
954141	6,0	240	13,0	70	TX30 •	100
954142	6,0	260	13,0	70	TX30 •	100
954143	6,0	280	13,0	70	TX30 •	100
954144	6,0	300	13,0	70	TX30 •	100
954145	8,0	80	18,0	48	TX40 •	50
954146	8,0	100	18,0	60	TX40 •	50
954147	8,0	120	18,0	60	TX40 •	50
954148	8,0	140	18,0	95	TX40 •	50
954149	8,0	160	18,0	95	TX40 •	50
954150	8,0	180	18,0	95	TX40 •	50
954151	8,0	200	18,0	95	TX40 •	50
954152	8,0	220	18,0	95	TX40 •	50
954153	8,0	240	18,0	95	TX40 •	50
954154	8,0	260	18,0	95	TX40 •	50
954155	8,0	280	18,0	95	TX40 •	50
954156	8,0	300	18,0	95	TX40 •	50
954157	8,0	320	18,0	95	TX40 •	50
954158	8,0	340	18,0	95	TX40 •	50
954159	8,0	360	18,0	95	TX40 •	50
954160	8,0	380	18,0	95	TX40 •	50
954161	8,0	400	18,0	95	TX40 •	50
954181	8,0	420	18,0	95	TX40 •	50
954182	8,0	440	18,0	95	TX40 •	50
954183	8,0	460	18,0	95	TX40 •	50
954184	8,0	480	18,0	95	TX40 •	50
954185	8,0	500	18,0	95	TX40 •	50
954186	8,0	550	18,0	95	TX40 •	50
954187	8,0	600	18,0	95	TX40 •	50
954162	10,0	100	22,0	60	TX50 •	50
954163	10,0	120	22,0	60	TX50 •	50
954164	10,0	140	22,0	95	TX50 •	50
954165	10,0	160	22,0	95	TX50 •	50
954166	10,0	180	22,0	95	TX50 •	50
954167	10,0	200	22,0	95	TX50 •	50
954168	10,0	220	22,0	95	TX50 •	50
954169	10,0	240	22,0	95	TX50 •	50
954170	10,0	260	22,0	95	TX50 •	50
954171	10,0	280	22,0	95	TX50 •	50
954172	10,0	300	22,0	95	TX50 •	50
954173	10,0	320	22,0	95	TX50 •	50
954174	10,0	340	22,0	95	TX50 •	50
954175	10,0	360	22,0	95	TX50 •	25
954176	10,0	380	22,0	95	TX50 •	25
954177	10,0	400	22,0	95	TX50 •	25

# TOPDUO ROOFING AND FACADE SCREW

The wood-construction screw for all over-rafter insulation systems

The Topduo roofing and facade screw can be used to **fasten both compression-resistant and non-compression-resistant above-rafter insulation**. The **high pull-out resistance** in both connecting timbers also makes the TopDuo roofing screw suitable for many other applications in timber construction. The screw has a **double thread and is available with a flanged buttonhead and cylinder head**.

## Cylinder head

- Virtually disappears in wood
- Speeds up the screwing-in process

## Underhead thread with cutting notches

- Keeps the gap between wooden structural elements

## Coarse thread with cutting notches

- The coarse thread is equipped with sharp rolled edges all the way to the tip
- Speeds up the screwing-in process

## Friction part

- Reamer creates space for the shank, reducing the screw-in resistance

## DAG screw tip

- The special geometry of the DAG screw tip ensures a reduction of the screwing torque and also leads to a lower splitting effect when screwing-in

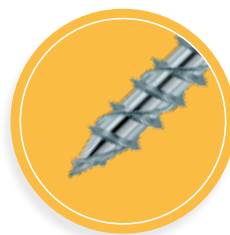

### TopDuo Carbon Steel

Geometric properties						Mechanical properties			
Nominal Ø [mm]	Root Ø <sub>i</sub> [mm]	Shaft Ø <sub>s</sub> [mm]	Head <sup>a)</sup> Ø <sub>h</sub> [mm]	Higher thread length [mm]	Lower thread length [mm]	f <sub>tens,k</sub> [kN]	f <sub>ax,k</sub> [MPa]	f <sub>head,k</sub> [MPa]	M <sub>y,k</sub> [Nm]
8	5,3	5,8	10,0 / 16,0	60	95	20,0	11,1	12,0	20,0

<sup>a)</sup> Cylinder head / Washer head

## FASTENING OPTIONS:

Topduo is suitable for pressure resistant ( $\geq 50$  kPa) and non-pressure resistant insulations.

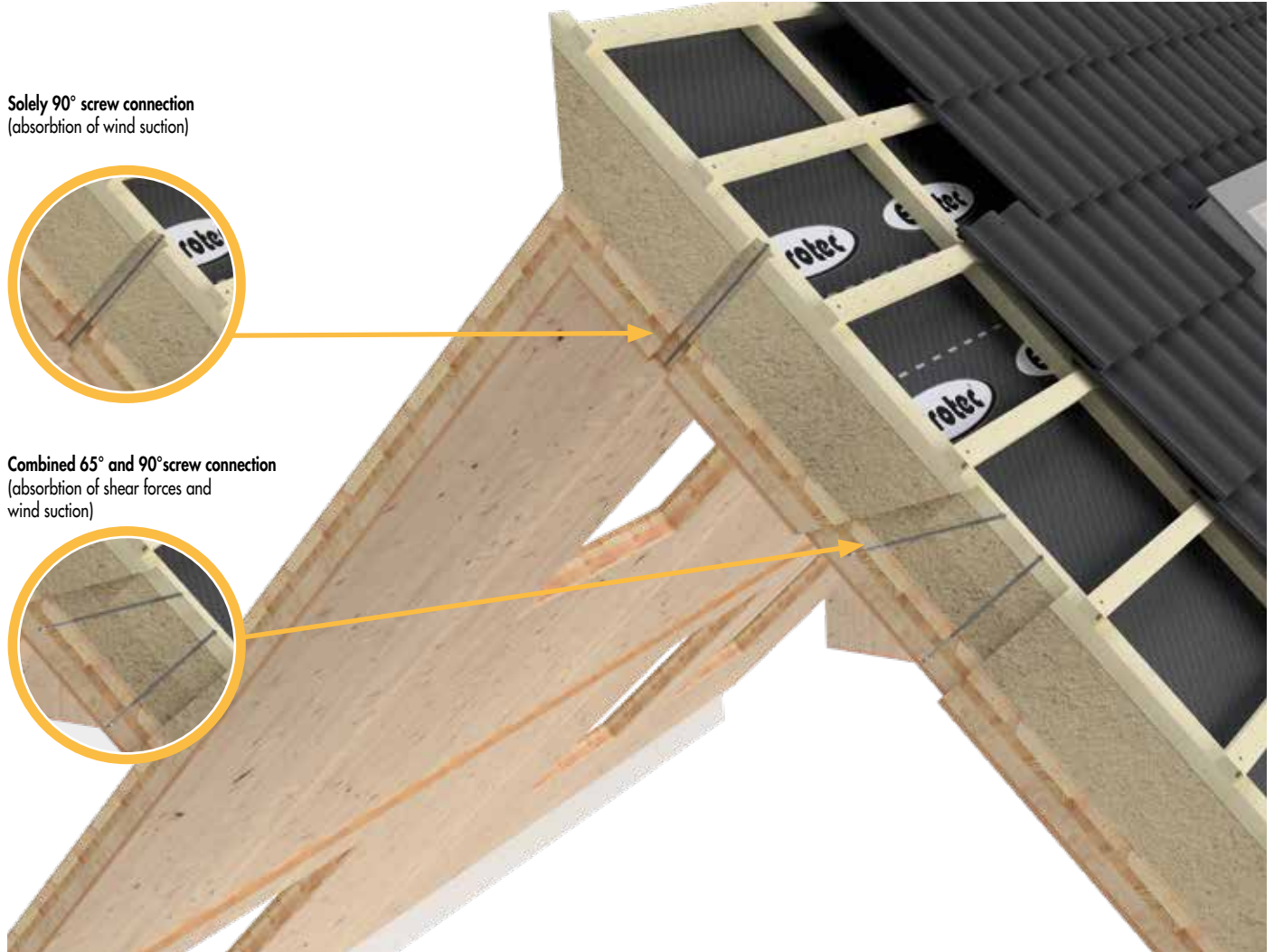

**Solely 90° screw connection**  
(absorption of wind suction)



**Combined 65° and 90° screw connection**  
(absorption of shear forces and wind suction)

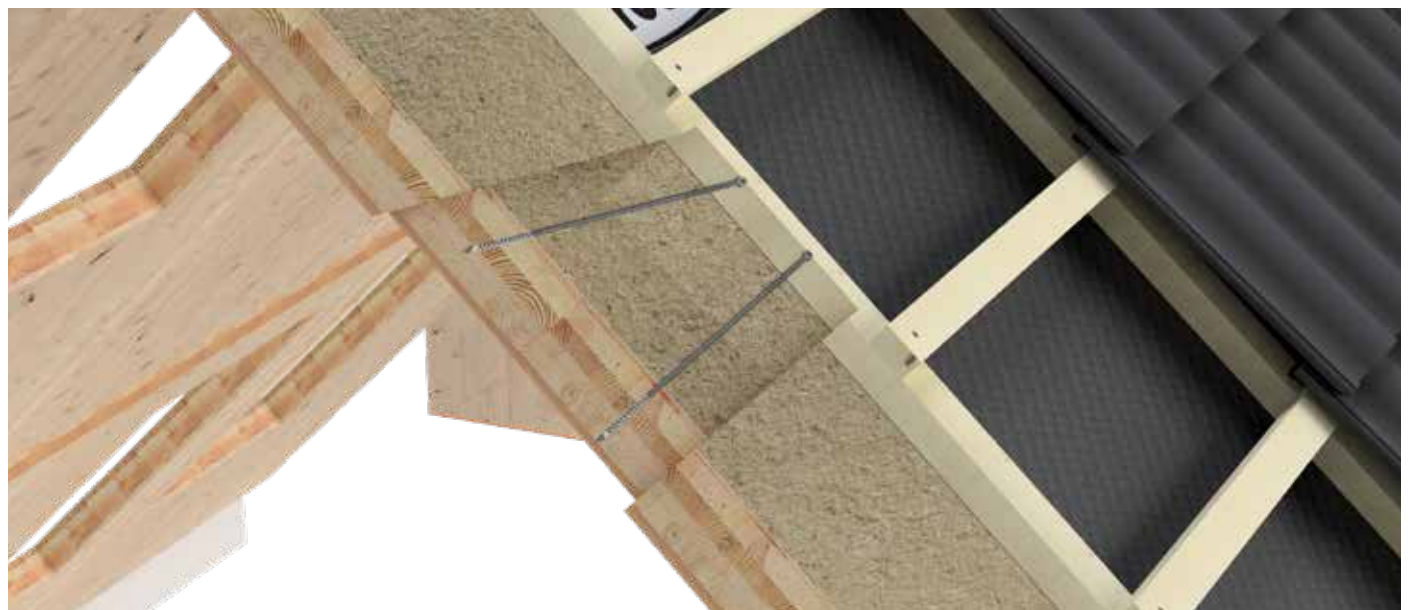

*Topduo cylinder head for fastening insulation material*

# TOPDUO ROOFING AND FACADE SCREW

The wood-construction screw for all over-rafter insulation systems



## Topduo roofing screw

Washer head, hardened carbon steel, electrogalvanised



Art. no.	Ø d [mm]	L [mm]	Ø dh [mm]	lg1 /lg2 [mm]	Drive	PU
945870	8,0	165	16,0	60/66	TX40 ●	50
945871	8,0	195	16,0	60/95	TX40 ●	50
945813	8,0	225	16,0	60/95	TX40 ●	50
945814	8,0	235	16,0	60/95	TX40 ●	50
945815	8,0	255	16,0	60/95	TX40 ●	50
945816	8,0	275	16,0	60/95	TX40 ●	50
945817	8,0	302	16,0	60/95	TX40 ●	50
945818	8,0	335	16,0	60/95	TX40 ●	50
945819	8,0	365	16,0	60/95	TX40 ●	50
945820	8,0	397	16,0	60/95	TX40 ●	50
945821	8,0	435	16,0	60/95	TX40 ●	50
945843	8,0	472	16,0	60/95	TX40 ●	50

## Topduo roofing screw

Cylinder head, hardened carbon steel, electrogalvanised



Art. no.	Ø d [mm]	L [mm]	Ø dh [mm]	lg1 /lg2 [mm]	Drive	PU
946027	8,0	165	10,0	60/95	TX40 ●	50
946028	8,0	195	10,0	60/95	TX40 ●	50
945956	8,0	225	10,0	60/95	TX40 ●	50
945965	8,0	235	10,0	60/95	TX40 ●	50
945957	8,0	255	10,0	60/95	TX40 ●	50
945958	8,0	275	10,0	60/95	TX40 ●	50
945960	8,0	302	10,0	60/95	TX40 ●	50
945961	8,0	335	10,0	60/95	TX40 ●	50
945962	8,0	365	10,0	60/95	TX40 ●	50
945963	8,0	397	10,0	60/95	TX40 ●	50
945964	8,0	435	10,0	60/95	TX40 ●	50



Roof construction with Topduo

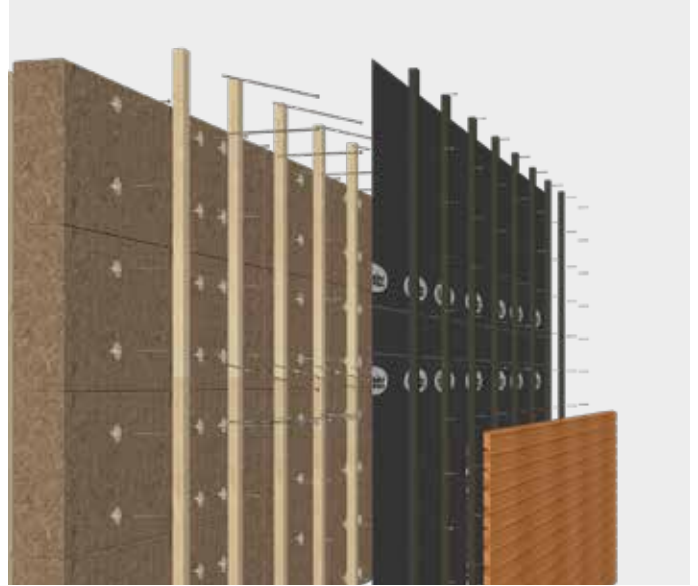

Façade construction with the Topduo roofing screw



Topduo washer head for fastening insulation material

## TAURUS 45°

The Taurus 45 has been developed to provide a suitable fixing between a steel plate and timber member by means of installing fully-threaded screws at an angle. In the steel plates, only simple round holes are milled / Drill tipped or lasered to prevent the Taurus from sliding out. With Taurus, the screws are affixed at a 45° angle to ensure the simpler and faster transfer of shear forces. The Taurus 45° is compatible with Ø 8–10 mm KonstruX ST.



Art. no.	Dimensions [mm] <sup>a)</sup>	Plate hole diameter [mm]	Plate thickness [mm]	Weight [g]	KonstruX ST SK	PU
800313	28 x 16 x 17,8	Ø 15	3 to 4	30	Ø 6,5	10
800268	29 x 19 x 19,5	Ø 17	3 to 5	34	Ø 8	10
800269	43 x 26 x 25	Ø 26	3 to 10	115	Ø 10	10

a) length x width x height

STEEL-TIMBER, INCLINED SCREWS (KONSTRUX ST COUNTERSUNK HEAD) WITH TAURUS 45° WASHER

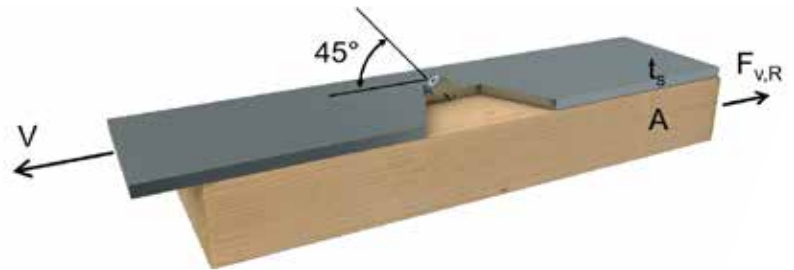
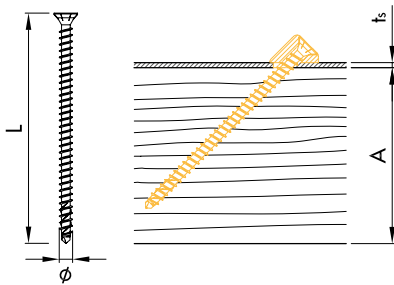

## APPLICATION IMAGE



## LBS CONSTRUCTION SCREW

Eurotec LBS construction screws are special fasteners for use in laminated hardwood veneer lumber. Thanks to their special screw geometry and the properties of steel, they can be screwed straight into this material without pre-Drill tipping. The special geometry of the DAG screw tip reduces screw-in torque and causes less splitting when screwing in.



Art. no.	Ø d [mm]	L [mm]	Ø dh [mm]	lg [mm]	Drive	PU
904881	8,0	80	15	50	TX40 •	50
904882	8,0	100	15	80	TX40 •	50
904883	8,0	120	15	80	TX40 •	50
904884	8,0	140	15	80	TX40 •	50
904885	8,0	160	15	80	TX40 •	50
904886	8,0	180	15	80	TX40 •	50
904887	8,0	200	15	80	TX40 •	50
904888	8,0	220	15	80	TX40 •	50
904889	8,0	240	15	80	TX40 •	50

LBS Carbon Steel								
Geometric properties					Mechanical properties			
Nominal Ø [mm]	Root Øi [mm]	Shaft Øs [mm]	Head <sup>a)</sup> Øh [mm]	Thread length [mm]	f <sub>tens,k</sub> [kN]	f <sub>ax,k</sub> [MPa]	f <sub>head,k</sub> [MPa]	M <sub>y,k</sub> [Nm]
8	6,1	6,4	15,0	50-80	30,0	15 / 25 / 30	24,5	36,0

<sup>a)</sup> Softwood LVL and Hardwood 500 kg/m<sup>3</sup> / Pre-Drill tipped Hardwood LVL 730 kg/m<sup>3</sup> / Non-preDrill tipped 730 kg/m<sup>3</sup>

### ADVANTAGES AND SPECIFICATIONS

- Pre-Drill tipping is not necessary
- Can be used in laminated hardwood, softwood veneer lumber and softwood in general
- DAG tip requires less screw-in torque
- Minimal splitting effect
- Optimised anti-friction coating for use in hardwoods
- Screws can be screwed in smoothly thanks to the TX drive

### APPLICATION IMAGE



The LBS construction screw in laminated beech veneer lumber

## SPEED LIMITER

Modern screw-in tools – whether mains or battery operated – are becoming ever more powerful. This development comes with an increasing risk, i.e. that the screws may be exposed to excessive loads during the screwing process. This leads to characteristic damage profiles, e.g. ripped-off screw heads, over-tightened threads or deformed components, especially in demanding metal-timber joints. The screw-in coupling offers an effective solution for this issue. It reliably limits the torque to a specified value. Once this has been reached, an internal shut-down mechanism disconnects the power transmission, which protects the screws and materials from destruction and ensures consistently secure screw connections.

This makes the tool ideal for professional users who value clean and controlled installations – without compromising on speed.



Drehzahlbegrenzer	
Feature	Specification
Available models	18 Nm
	32 Nm
Drives	Hex 11 mm
Total length	120,5 mm
Bit holder	TX40 • or TX50 •
Lubrication condition	Maintenance-free thanks to permanent lubrication
Art. no.	100885 (18 Nm)
	100886 (32 Nm)

### ADVANTAGES AND SPECIFICATIONS

- Reduces screw damage: it prevents the over-tightening and breaking off of screws, which is particularly important for metal-timber connections and for washer head screws.
- Consistent quality: a safe and reproducible tightening torque for each screw connection.
- **Maintenance-free:** the permanently lubricated coupling requires no regular care.

### APPLICATION IMAGE



## THE SCREW-IN TOOL

The screw-in tool has been specially designed for the mechanical screwing of wood and spacer screws. It creates a non-positive and centric connection between the screw head and tool, which guarantees a precise and controlled screwing process – even at higher screw-in torques.



The screw-in tool	
Feature	Specification
Type	100883: Screw-in tool small ESW8 100884: Screw-in tool large ESW13
Tool holder	1/4" hex (internal hex drive)
Drives	TX40 • or TX50 •
Length	approx. 65 mm
Diameter (external)	41,5 mm
Compatibility	Art.-Nr.100883: Screws with a TX40 drive (e.g. Paneltwistec TK Ø8xL) Art.-Nr.100884: Screws with a TX40 drive (e.g. Paneltwistec TK Ø10xL)
Use	Suitable for use with cordless screwdrivers/power Drill tips

### ADVANTAGES AND SPECIFICATIONS

- A robust and durable design for use on construction sites
- Secure grip thanks to the precise fit
- Prevents slipping or jamming during the screwing process
- Suitable for pre- and final installations in timber construction, façade construction, substructures, etc.

### APPLICATION IMAGE



# MATERIAL AND COATING

## Overview

Eurotec invests in high-quality materials and surface coatings to ensure long-term durability and corrosion resistance. These properties are of critical importance as they extend the fasteners' service life and improve their performance in a variety of applications – for long-lasting connections in anything from wood construction projects to industrial use cases.



### Hardened carbon steel + blue/yellow galvanised finishes

- Suitable for service classes 1 and 2 in accordance with DIN EN 1995 (Eurocode 5)
- Good resistance to mechanical stress
- Not suitable for timbers that contain tannins



### Hardened carbon steel + special coating 1000 or Hardened carbon steel, black coated

- Suitable for service classes 1 and 2 in accordance with DIN EN 1995 (Eurocode 5)
- Withstands up to 1,000 hours of salt-spray testing in accordance with DIN EN ISO 9227 NSS
- Corrosion category C4 long/C5-M long in accordance with DIN EN ISO 12944-6
- Good resistance to mechanical stress
- Not suitable for timbers that contain tannins



### Hardened stainless steel

- Stainless steel in accordance with DIN 10088 (magnetisable)
- Limited acid resistance
- 10 years of experience without corrosion problems using suitable timbers
- 50% higher breaking torque than A2 and A4
- Suitable for service classes 1, 2 and 3
- Not suitable for timbers that are high in tannins such as cumaru, oak, Merbau, robinia etc.
- Not suitable for saline or chlorous atmospheres



### Stainless steel A2

- Limited suitability for saline atmospheres
- Limited acid resistance
- Not suitable for chlorous atmospheres
- Suitable for service classes 1, 2 and 3
- Limited suitability for timbers that are high in tannins



### Stainless steel A4

- Suitable for timbers that contain tannins
- Suitable for saline atmospheres
- Acid resistant
- Suitable for service class 1, 2 and 3
- Not suitable for chlorous atmospheres





## LINKS TO RELATED BROCHURES

OUR PRODUCT RANGE  
WOOD CONSTRUCTION SCREWS



EXPERT KNOWLEDGE FOR USERS  
TIMBER/CONCRETE COMPOSITE (TCC) SYSTEM



OUR  
LIFTING AND TRANSPORT SOLUTIONS



FASTING SOLUTIONS  
ROOF



OUR  
STRUCTURAL TIMBER DESIGN GUIDE



SEISMIC PERFORMANCE  
EUROTEC WOOD CONSTRUCTION SCREW



ICC-ES CERTIFICATE  
DESIGN GUIDE FOR STRUCTURAL WOOD SCREWS





# INDEX

<b>A</b>	Angle-bracket with a rib .....	22/36
	Angle-bracket screw .....	80-83
	Anchor nail.....	84-85
<b>C</b>	CLT bracket.....	23/37
	CLT system angles.....	32
	CLT inside corners .....	33
	Connecto.....	54-55
<b>E</b>	Ecktec.....	58-59
<b>I</b>	IdeeFix .....	56
<b>J</b>	Joist hangers.....	57
<b>K</b>	KonstruX fully threaded screw .....	62-69
	KonstruX DUO .....	70-71
	KonstruX, 13 mm E12.....	72-79
<b>L</b>	LBS construction screw .....	119
<b>M</b>	Magnus hook connectors .....	52
<b>P</b>	Perforated panels and perforated panel strip.....	40
	Panelwistec.....	86-111
	Pedix post feet.....	48-49
<b>S</b>	Shearing angle .....	20-21/34-35
	Shearing plate .....	24/39
	Simply tie-bar .....	28/43
	Structus .....	46-47
	Speed limiter.....	120
	Shear wall connector.....	40
	Sawtec .....	112-113
<b>T</b>	Tension-strap HB60/70 .....	25/38
	Tension-rods 340/440/540/620.....	26/42
	Tension-rod Highload .....	27
	Tension-strap HH60/70 and Highload.....	38
	<b>T-Tec system:</b> T-Profile and EST rods .....	53
	TopDuo roofing and facade screw .....	114-117
	Taurus 45°.....	118
	The screw-in tool.....	121



# CONDITIONS OF SALE AND DELIVERY

All sales to buyers, customers and contract partners, hereinafter referred to as customers, are made exclusively subject to the following terms and conditions unless other agreements are made in writing in the individual case:

## 1. SCOPE, GENERAL PROVISIONS

Our terms and conditions shall apply exclusively! We will not accept contradictory terms and conditions of our customers that deviate from our conditions unless we have given our express written consent to their validity. Our terms and conditions shall apply even if we execute orders without reservation despite being aware of contradictory conditions or conditions that deviate from our terms and conditions. Our terms and conditions shall also apply to all future transactions with our customers. Customers can access the latest version of these Standard Terms and Conditions at [www.eurotec.team](http://www.eurotec.team) at any time.

## 2. OFFERS, WRITTEN FORM

Our offers are non-binding and subject to alteration without notice until we issue our final order confirmation. Contracts and agreements, as well as transactions brokered by our representatives, shall become binding only when we issue our written order confirmation. Verbal agreements, even within the framework of contract execution, are not valid unless confirmed by us in writing.

## 3. PRICES, PACKAGING, OFFSETTING

Unless otherwise indicated by the order confirmation, our prices are ex-works and exclusive of packaging. This is billed separately. The minimum order value is €50.00. For smaller quantities, we charge a flat processing fee of €30.00.

- Our prices are exclusive of statutory value added tax. This is stated and charged separately in the invoice at the statutory rate applicable on the date of billing.
- Our customer may only claim a right of offsetting insofar as counterclaims are established to be legally binding or are undisputed or accepted. A right of retention may only be exercised with respect to counterclaims resulting from the same contractual relationship.

## 4. DELIVERY, DELIVERY PERIOD AND FORCE MAJEURE

Unless otherwise agreed in writing, the place of performance shall be our company premises. The goods are shipped at the customer's risk and expense by third parties acting on our behalf. From the time at which the goods are made ready for delivery and the customer has been informed of their readiness for shipping, the customer shall bear the risk of accidental loss or deterioration of the item. This shall apply even if shipping is delayed as a result of circumstances for which we are not responsible. Punctual handing over of the goods to a shipping company requires that the order be placed on time by our customer. If the goods are handed over to the asphalted shipping company punctually, we will not be liable for delayed delivery to the customer. This shall apply even if a delivery deadline was agreed with the customer, especially in the case of delivery to a construction site. The customer may be exempted from rush charges incurred in relation to this if there is a legal basis for deducting this surcharge from the forwarder's bill.

Statements relating to delivery periods are always to be seen only as approximate and non-binding. They shall begin on the date of our order confirmation but not before all of the order details are clarified in full. They refer to the time of consignment ex-works and shall be considered met when the goods are reported to be ready for dispatch. Without prejudice to our rights arising due to the customer's default, they shall be extended by the period for which the customer is in arrears to us with respect to their obligations arising from this or other orders.

Even if they arise at our suppliers, the following grounds are among those that shall release us from the obligation to adhere to the delivery period and shall entitle us to extend the delivery periods, to make partial deliveries or to wholly or partially withdraw from the part of the contract that is not yet fulfilled without becoming liable to pay damages as a result, unless we are guilty of intent or gross negligence: interruptions of operations and difficulties in delivery of any kind, e. g. shortages of machinery, goods, materials or fuels, or incidents of force majeure, e. g. export and import embargos, fires, strikes, lock-outs or new official measures that adversely affect production costs and shipping.

## 5. SHIPPING

Goods are shipped at the expense and risk of the customer even if prepaid delivery was agreed. Additional costs for express shipping shall always be borne by the customer. Freight costs paid by us are to be seen only as an advancement of freight charges on behalf of the customer. Additional freight costs for urgent and express parcels shall be borne by the customer, even if we have borne the transport costs on individual occasions. Goods reported as ready for shipping must be accepted immediately and will be charged as exworks. If the goods are to be shipped abroad or passed directly to third parties, they must be examined and accepted in our factory; otherwise, the goods shall be deemed to have been delivered in accordance with the contract to the exclusion of any complaints. The risk, including that of confiscation, shall be transferred to the customer when the goods are handed over to the forwarder or freight carrier and, at the latest, when they leave our facility. Return shipments always require prior consultation with our internal sales department. Goods that are free of defects are only taken back with our express consent. A credit note is then issued for the value of the goods with deduction of a 25% return fee per item or against a minimum fee of €50 for returning the goods to storage. Strictly no debit notes are accepted.

## 6. DESIGN AND PROPERTY RIGHTS

The customer shall bear sole responsibility and be liable for ensuring that the goods it orders do not violate thirdparty property rights. No verification is performed on our part in this respect. The customer shall indemnify us against injunctions or claims for damages by third parties. If an injunction is requested against us, the customer shall meet the legal costs and shall compensate us for the damages we have incurred.

## 7. ACCEPTANCE, QUANTITY TOLERANCES AND CALL-OFFS

For contracts with ongoing deliveries, the goods are to be accepted in monthly quantities that are as consistent as possible over the course of the contractual period. If a call-off is not made on time, we shall be entitled, after the expiry of a grace period that we have granted, to divide the order at our own discretion, withdraw from the part of the contract that has not yet been executed, or make a claim for damages due to non-performance. In the case of call-off orders, the call-offs must always be made within 12 calendar months. Over- or under-shipment by up to 10% of the order shall be permissible.

## 8.1 PAYMENT TERMS FOR INVOICES, RIGHT OF RETENTION

Invoices shall be payable with a 2% discount within 10 days of the invoice date or net within 30 days, regardless of when the goods are received and without prejudice to the right to make a complaint for defects. Payment by means of acceptance or customer's bill of exchange shall require special written agreement in advance. Discount charges will be charged in the case of payment by means of acceptance, which must have a term no longer than 3 months and be issued within 1 week of the invoice date. Credit notes for bills of exchange or cheques shall apply subject to receipt and regardless of the purchase price's earlier due date in the event of default by the customer. They shall be issued with the value at the date on which the equivalent amount will be available to us; the discount charges will be charged at the respective bank rate. In the event that the payment term is exceeded, interest and commissions may be charged without prejudice to other rights at the respective bank rate for overdrafts but at a rate at least 5%

above the respective discount rate of the Deutsche Bundesbank [German Federal Bank]. If the payment terms are not adhered to or we become aware of circumstances that, in our view, are sufficient to reduce the customer's credit worthiness, all of our claims shall become payable immediately regardless of the term of any bills of exchange that have been accepted or credited.

We shall then also be entitled to perform outstanding deliveries only in exchange for advance payment, to withdraw from the contract after a reasonable grace period, and to demand compensation for default. We may also prohibit the resale or processing of the delivered goods and demand their return or the transfer of indirect possession of the delivered goods at the customer's expense. The customer hereby already authorises us to enter its premises and confiscate the delivered goods in the above cases. We shall be entitled to the usual securities for our claims according to their nature and extent, even if they are subject to conditions or of limited duration. Offsetting or withholding payments as a result of any counterclaims or notifications of defects shall be prohibited, except where claims are undisputed or established to be legally binding.

## 8.2 TERMS OF PAYMENT FOR WEB-SHOP CUSTOMERS

Payment shall be made exclusively in advance. Once the order process in our online shop is complete, you will receive an email with the bank details for our business account. The invoiced amount must be transferred to our account within 7 days. We cannot carry out your order until the payment arrives.

## 9. RETENTION OF TITLE

Until all liabilities arising from the business relationship are paid in full and, in particular, until all bills of exchange and cheques, including finance bills, given as payment are cashed, the goods delivered by us shall remain our property and may be taken back by us at the customer's expense in the event of default in payment. Until this point, the customer shall not be entitled to pledge or assign the goods to third parties as a security; it may sell them on or process them only within the framework of its ongoing business transactions. The customer shall be obliged to inform us immediately of any seizure by third parties of the goods delivered subject to retention of title. In the event of further processing, the customer shall not acquire ownership of the goods delivered by us as set out in section 950 of the German Civil Code (BGB), as any processing is carried out by the customer on our behalf. Without prejudice to the rights of third-party suppliers, the newly created thing shall serve as security for us up to the amount of our total claims arising from the business relationship. It shall be kept safe for us by the customer and shall be regarded as goods for the purpose of these terms and conditions. If the item is intermixed or otherwise combined with other objects that do not belong to us, we shall acquire at least co-ownership of the new thing in proportion to the value of the contract item to that of other objects that have been processed with it. If the customer sells the goods delivered by us, regardless of their condition, it hereby already assigns to us all claims against its customers arising from sales, as well as all ancillary rights, until all of our claims arising from delivery of goods are paid in full. At our request, the customer shall be obliged to notify its downstream customers of the assignment and to hand over the information and documents we require in order to assert our rights against its downstream customers. If the total value of the securities given to us exceeds our claims arising from delivery by more than 20%, we shall be obliged to retransfer securities to this extent at the customer's request. If the retention of title or assignment is invalid in the territory in which the goods are located, a security corresponding to the retention of title or assignment in this territory shall be deemed to be agreed. If the customer's cooperation is required in this process, it shall take all necessary measures to establish such rights.

## 10. NOTIFICATION OF DEFECTS, LIABILITY

Our customer shall be entitled to a warranty only if they have properly fulfilled their legal obligations under sections 377 and 378 of the German Commercial Code (HGB) with respect to the duties of examination and notification. If defects are present, we shall be entitled at our choice to either repair the defects or provide a replacement; if we are not prepared or not able to do so, and especially if repair/replacement is delayed beyond reasonable deadlines for reasons that we are responsible for, or if repair/replacement otherwise fails, our customer shall be entitled at its choice to withdraw from the contract or to demand a corresponding reduction in the price. Unless otherwise stipulated below, further claims of the customer shall be excluded regardless of their legal basis. We shall not be liable for damage that did not occur to the delivered item itself. In particular, we shall not be liable for lost profit or other pecuniary losses of the customer. The above exemption from liability shall not apply if the damage is caused by intent or gross negligence; it shall also not apply if the customer asserts claims for damages for non-performance due to the lack of a warranted characteristic. If we breach an essential contractual duty through negligence, our duty of reimbursement for property damage or personal injury shall be restricted to the level of cover provided by our product liability insurance.

We are prepared to allow the customer to view our policy. The warranty period is 6 months calculated from the date of transfer of risk. This period is a limitation period. The period shall also apply to claims under sections 1 and 4 of the German Product Liability Act (ProdHaftG). Insofar as our liability is excluded or restricted, this shall also apply to the personal liability of our employees, workers, staff, representatives and agents. Goods that are subject to a complaint must not be sent back without obtaining our prior written consent, as otherwise we may refuse to accept them at the sender's expense. Goods that have been partially or wholly processed will not be taken back under any circumstances. The customer is obliged to make sure that the purchased product is suitable for the intended application using technical descriptions, where available, and based on their specialist knowledge and to familiarise themselves with the application of this product. If they are not familiar with the product's application, our company staff are available to provide advice. All information and advice from our staff is provided carefully and conscientiously. Under no circumstances does this information and advice replace the indispensable consultancy services of architects and specialist planning companies or the services they provide during construction. Only the authorised professional groups are entitled to provide these services.

## 11. PLACE OF PERFORMANCE AND JURISDICTION, MISCELLANEOUS

Our company's registered office shall be the place of performance for all obligations arising from this contract, including liabilities from cheques and bills of exchange. Provided our customer is a merchant, the place of jurisdiction for all disputes arising from the contractual relationship shall be, at our choice, the Local Court of Hagen. Contracts with our customer shall be governed exclusively by German law to the exclusion of the UN Convention on Contracts for the International Sale of Goods of 11 April 1980. The language of the contract shall be German.

Hagen, 16. February 2018

E.u.r.o.Tec GmbH

Unter dem Hofe 5 · 58099 Hagen

Managing directors: Markus Rensburg, Gregor Mamys

Court of registration: Local Court of Registration number HRB 3817 VAT ID No.: DE 812674291

Tax number: 321/5770/0639

Tel. +49 2331 62 45-0 • Fax +49 2331 62 45-200 • email [info@eurotec.team](mailto:info@eurotec.team) • [www.eurotec.team](http://www.eurotec.team)

# Eurotec®

The specialist for fastening technology

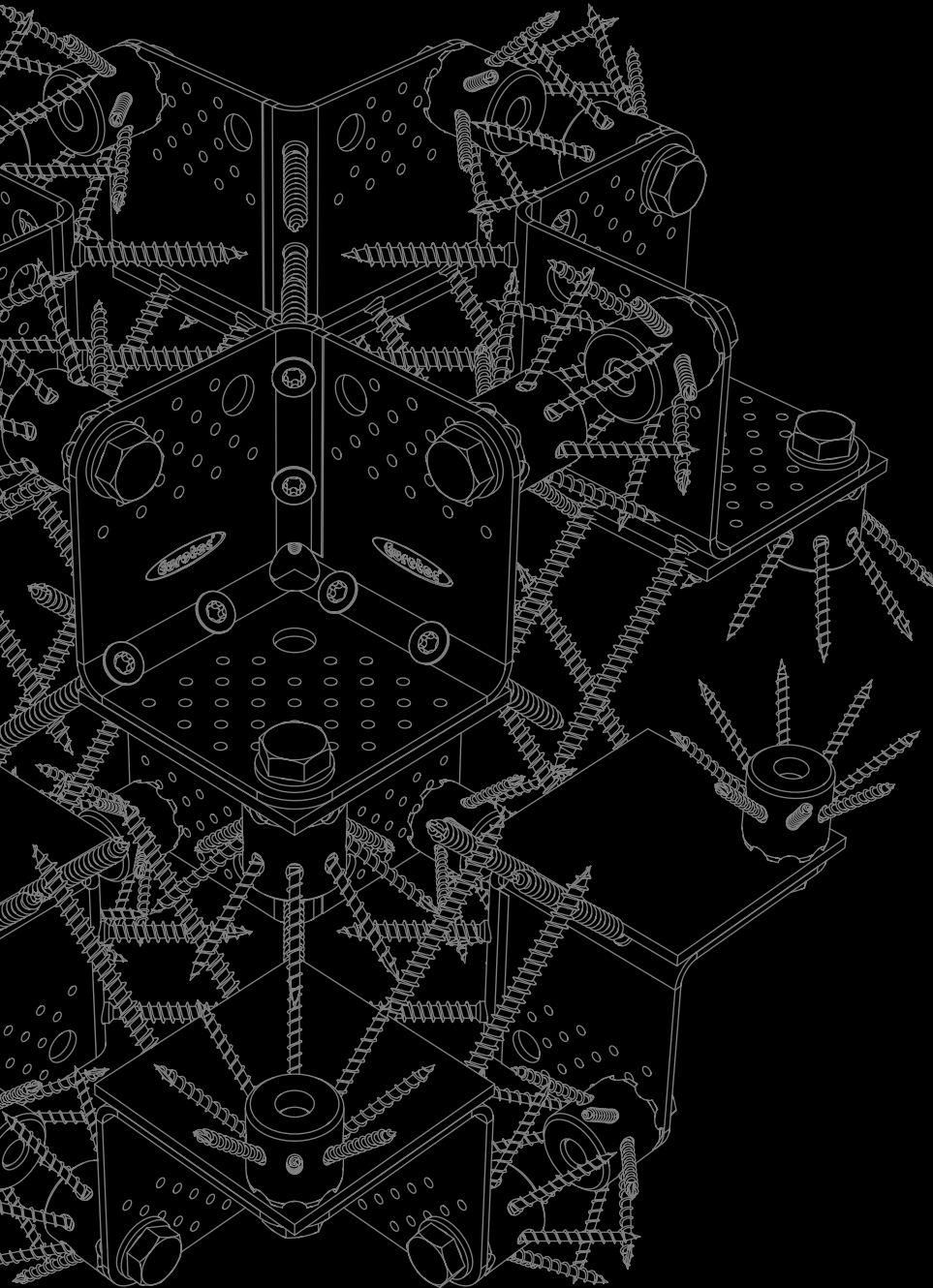

Publisher: E.u.r.o.Tec GmbH - Revised: 06/2026

The content is subject to errors and technical changes and additions. All dimensions are approximate values.

The information is subject to model and colour deviations, as well as errors.

We accept no liability for printing errors. Reprinting (even in part) is only permitted with E.u.r.o.Tec GmbH's prior approval.

**E.u.r.o.Tec GmbH**

Unter dem Hofe 5 · D-58099 Hagen

Tel. +49 2331 62 45-0

Fax +49 2331 62 45-200

E-Mail [info@eurotec.team](mailto:info@eurotec.team)

Follow us



[www.eurotec.team/en](http://www.eurotec.team/en)